



[www.vdo.com](http://www.vdo.com)

# Special Vehicle products Catalogue 2019

OEM solutions for Special Vehicles

**VDO**



# The future of Mobility starts with Today's Innovations

As a global provider of mobile technologies, our passion for mobility reinforces everything we do. Mobility is more than just effectiveness, it is the driving force that allows us to reach new goals, progress, and push us beyond the boundaries. The concept of mobility is at the center of our vision and is reflected in everything we do.

Our employees around the world are united by their common enthusiasm for modern vehicles and cars, and opportunities that technology offers. The ability to adopt new ideas is just as important for us as experience, targeted research, and development. That's why experts from a wide range of industries work in our company. Today our innovative products are proof of the success of this operating model.

Examples include VDO products for a wide range of vehicles and special machinery. These system solutions and individual components meet the most demanding requirements, but at the same time offer maximum driving and working comfort.

## **Our catalog: always updated**

We want our catalog of electronic devices for vehicles to be a reliable companion always at your side to help you in your work. To guarantee this we keep it constantly updated. You will be informed of these updates by e-mail. This means that you can always have the latest information available with just a few clicks.

The process is simple:

### **If you already have access to the extranet**

Direct access	Direct connection on the Extranet home page or via the following link: <b><a href="https://extranet.continental-partner.com">https://extranet.continental-partner.com</a></b>
---------------	--

### **If you do not have access to the extranet yet**

Please register to:	<b><a href="https://extranet.continental-partner.com">https://extranet.continental-partner.com</a></b> and select Register and enter your details. You will be sent an e-mail with the login credentials
---------------------	--

To find updates	<b>use the link mentioned above</b>
-----------------	-------------------------------------

### **Visit us on [www.vdo.com](http://www.vdo.com)**

Visit **[www.vdo.com](http://www.vdo.com)** to find out about the latest news on our products and their innovative features, to find the nearest store, or for more information on the world of mobility.

## INDEX

<b>1. Instrumentation</b>	<b>7</b>
<b>1.1 Single Gauges</b>	<b>8</b>
1.1.1 SingleViu® (CAN / Analogue)	9
1.1.2 Cockpit International	23
<b>1.2 Analog Instrument Clusters</b>	<b>28</b>
1.2.1 Centrobase 500	29
<b>1.3 CAN Instruments Clusters</b>	<b>30</b>
1.3.2 FlexCluster	31
<b>2. Sensors and Switches</b>	<b>33</b>
<b>2.1 Speed and RPM Sensors</b>	<b>33</b>
2.1.1 Blocking oscillators Sensors	34
2.1.2 Inductive Sensors	36
2.1.3 Hall effect Sensors	38
2.1.4 Generator Sensors	39
2.1.5 Active wheel speed Sensor	40
<b>2.2 Pressure Sensors</b>	<b>41</b>
2.2.1 Pressure sensors, Single-Pole, common ground	42
2.2.2 Pressure Sensors with Warning Contact, common ground	44
2.2.3 Pressure Sensors, insulated Return	47
2.2.4 Pressure Sensor with warning contact, 3 connections	48
<b>2.3 Pressure Switches</b>	<b>50</b>
2.3.1 Pressure Switches, single pole, common ground	51
2.3.2 Pressure Switches, insulated return	52
<b>2.4 Temperature sensors</b>	<b>53</b>
2.4.1 Temperature Sensors, Single-Pole, Common ground	54
2.4.2 Temperature Sensors, 2 Pole, Insulated return	56
2.4.3 Temperature Sensors with IP connector	57
2.4.4 Temperature Sensors with Warning contact	58
2.4.5 Air Temperature sensor	60
2.4.6 Temperature sensor (special version)	60
2.4.7 Pyrometer	61
<b>2.5 Temperature Switches</b>	<b>62</b>
2.5.1 Temperature Switches, single pole, common ground	63
2.5.2 Temperature Switches, 2 pole, insulated return	65
<b>2.6 Liquid level Switches</b>	<b>66</b>
2.6.1 Liquid Level Switches, linear type, for oil/Diesel	67
2.6.2 Liquid Level Switches, lever type, for water	68

<b>2.7 Specific Solutions: Sensors for engine management systems</b>	69
2.7.1 Electronic Pressure Sensors (EPS)	70
2.7.2 Intake air pressure Sensors (MAP, T-MAP)	71
2.7.3 Mass airflow Sensor (MAF)	72
2.7.4 Knock Sensor	73
2.7.5 Crankshaft Position Sensor	73
2.7.6 Camshaft Position Sensor	73
2.7.7 High temperature Sensor (HTS)	74
<b>2.8 Differential pressure sensor (2 ports) for particulate filters</b>	75
<b>2.9 Inertial Sensor</b>	76
<b>2.10 CPS - Chassis Position Sensor</b>	78
<b>2.11 Chassis Acceleration Sensor - BZS04 serie</b>	80
<b>2.12 UniNOx Sensor</b>	81
<b>2.13 ADAS Systems - Radar Sensors</b>	83
<b>3. Fuel and water Level Senders</b>	86
<b>3.1 Fuel and Water Level Senders, Tubular type</b>	88
3.1.1 Tubular Fuel Level senders, Metal, Standard	89
3.1.2 Tubular Fuel and Water Level senders, Stainless steel	92
3.1.3 Tubular Fuel level Sender, Plastic	94
<b>3.2 Fuel level Senders, Lever-Arm type</b>	96
3.2.1 Lever-arm Fuel Level sender, Plastic	97
3.2.2 Adjustable Lever-arm Fuel Level Sender, Standard/ALAS I	100
<b>4. Control Systems</b>	104
<b>4.1 Pedal Interface II</b>	105
<b>4.2 AGB III</b>	107
<b>4.3 E-Gas® Compact</b>	108
<b>4.4 Actuators</b>	110
<b>4.5 KIBES (Key to Integrated OnBoard Electronic Systems)</b>	113
<b>4.6 gVCU (generic Vehicle Control Unit)</b>	116
<b>4.7 DC-DC Converters</b>	117
<b>5. Audio Systems</b>	118
<b>5.1 Radio</b>	119
<b>5.2 Loudspeakers</b>	126
<b>5.3 Accessories</b>	128
<b>6. View Systems</b>	129
<b>6.1 Standard Line</b>	130
<b>6.2 Pro Line</b>	134
<b>7. Solutions and Applications</b>	139

# Flexible solutions for different applications

## On-Highway

Systems and technologies for commercial vehicles approved for road use

- Heavy vehicles (trucks)
- Mobile cranes
- Bus
- special vehicles (for example firefighters vehicles)



## Off-Highway

Robust and reliable solutions for heavy working conditions

- Construction Vehicles
- Agricultural and forestry machines
- Industrial trucks
- Special Vehicles (eg airport vehicles)
- Mining and harbor equipments



## Engines and stationary machines

Sensors, instruments and control units for stationary machines, e.g.

- Generators
- Compressors
- Engines
- Trasmissions



## Leisure vehicles

Customized solutions for sport and leisure vehicles such as:

- Quad, Jet Skis, Snowmobiles
- Bikes and scooters
- Sport cars





# 1. Instrumentation

- 1.1 Single Gauges
- 1.2 Analog Instrument Clusters
- 1.3 CAN Instrument Clusters



## 1.1 Single Gauges

1.1.1 SingleViu® (CAN / Analogue)

1.1.2 Cockpit International



### 1.1.1 SingleViu® (CAN / Analogue)

The SingleViu® platform gauges streamline the previous VDO gauges. SingleViu® covers all the applications of previous instruments and offers a coherent and flexible solution with state-of-the-art technology. SingleViu® instruments support both digital CAN bus transmission and traditional analogue sensors. The individual instruments for measuring temperatures, levels, pressures, voltage and current are available with a diameter of 52mm. Tachometers and speedometers are available in diameters of 80/85 or 100 mm. Devices with a diameter of 80/85 and 100mm have a push button and an LCD display that can show the driver a various number of parameters in “operation menu”.

#### General characteristics

- Variants for 52mm, 80/85mm and 100mm
- Compatibility with 2 type of signals: analogue and CAN SAEJ-1939
- Anti-fog and anti-reflective glass
- Operating Voltage 12V/24V
- Selectable RGB backlight color
- Illumination colors of dial and LCD can be set separately
- Up to 5 telltales
- Warning thresholds to trigger the internal telltale
- “Plug and Play” gauges
- Customization possibilities (other bezel, dial, features) on request. We offer mechanic options in our small series manufacturing location Birmingham (RSO UK)
- Configuration via free of charge “SingleViu ConfigTool” (sensor curves, illumination ecc.)
- Homologation UN-ECE and CE

#### Mechanical characteristics

- Bezel: black, metal, triangular profile
- Fixing with spinlock nut 52, 80/85, 100mm
- The 80mm gauges can be also placed in 85mm holes
- Outer lens in mineral glass
- Flame-resistant housing
- Protection class IP 67 (Front and rear with connector)
- Operating temperature: from -40 to +80 °C / LCD: from -20 to +80°C

#### General features of 80/85 and 100mm gauges

- A dot matrix display shows information in roll mode, e.g. odometer, engine counter, clock, fuel consumption, gear engaged (current / recommended), DTC DM1 diagnostics
- Content of the main information in roll mode different for tachometers and tachometers.
- Possibility to select the metric or US units.
- Possibility to display a welcome logo when switched on
- Possibility to configure the instrument also using the button on the front
- A Dongle (already used for Viewline and CAN Cockpit) is necessary to set the odometer and hour meter values





The gauges are available in 3 types of different packaging:

- 1) Single pack: box with one gauge and nut; mounting and safety instruction sheet
- 2) Bulk: industrial packaging containing 10 pcs (80/100mm gauges) or 25 pcs (52mm gauges)
- 3) Aftermarket pack: plastic blister containing all the components for a complete installation: gauge, connector cable (8-pin for 52mm gauges, / 8+12 pin for 80/100mm gauges), mounting and safety instruction sheet

### Variants and Order Part Numbers

#### 80/85mm SPEEDOMETERS



Single pack	Bulk (10 pcs)	Aftermarket pack	Backlight color	Scale (min-max-units)	Analogue Input type	CAN PGN	CAN SPN	CAN Source Address
A2C3832910001	A2C3832910010	A2C3832910030	WHITE	0 - 120 Km/h	pulses	65265	84	0xA7
A2C3832920001	A2C3832920010	A2C3832920030		0 - 140 mph	pulses	65265	84	0xA7
A2C3832930001	A2C3832930010	A2C3832930030		0 - 160 mph	pulses	65265	84	0xA7
A2C3832940001	A2C3832940010	A2C3832940030		0 - 200 Km/h	pulses	65265	84	0xA7
A2C3832950001	A2C3832950010	A2C3832950030		0 - 300 Km/h	pulses	65265	84	0xA7
A2C3832880001	A2C3832880010	A2C3832880030		0 - 30 mph	pulses	65265	84	0xA7
A2C3832890001	A2C3832890010	A2C3832890030		0 - 60 Km/h	pulses	65265	84	0xA7
A2C3832900001	A2C3832900010	A2C3832900030		0 - 90 mph	pulses	65265	84	0xA7
		A2C3832910031	AMBER	0 - 120 Km/h	pulses	65265	84	0xA7
		A2C3832920031		0 - 140 mph	pulses	65265	84	0xA7
		A2C3832930031		0 - 160 mph	pulses	65265	84	0xA7
		A2C3832940031		0 - 200 Km/h	pulses	65265	84	0xA7
		A2C3832950031		0 - 300 Km/h	pulses	65265	84	0xA7
		A2C3832880031		0 - 30 mph	pulses	65265	84	0xA7
		A2C3832890031		0 - 60 Km/h	pulses	65265	84	0xA7
		A2C3832900031		0 - 90 mph	pulses	65265	84	0xA7
		A2C3832910032	RED	0 - 120 Km/h	pulses	65265	84	0xA7
		A2C3832920032		0 - 140 mph	pulses	65265	84	0xA7
		A2C3832930032		0 - 160 mph	pulses	65265	84	0xA7
		A2C3832940032		0 - 200 Km/h	pulses	65265	84	0xA7
		A2C3832950032		0 - 300 Km/h	pulses	65265	84	0xA7
		A2C3832880032		0 - 30 mph	pulses	65265	84	0xA7
		A2C3832890032		0 - 60 Km/h	pulses	65265	84	0xA7
		A2C3832900032		0 - 90 mph	pulses	65265	84	0xA7

### 80/85mm SPEEDOMETERS:

Single pack	Bulk (10 pcs)	Aftermarket pack	Backlight color	Scale (min-max-units)	Analogue Input type	CAN PGN	CAN SPN	CAN Source Address
		A2C3832910033	GREEN	0 - 120 Km/h	pulses	65265	84	0xA7
		A2C3832920033		0 - 140 mph	pulses	65265	84	0xA7
		A2C3832930033		0 - 160 mph	pulses	65265	84	0xA7
		A2C3832940033		0 - 200 Km/h	pulses	65265	84	0xA7
		A2C3832950033		0 - 300 Km/h	pulses	65265	84	0xA7
		A2C3832880033		0 - 30 mph	pulses	65265	84	0xA7
		A2C3832890033		0 - 60 Km/h	pulses	65265	84	0xA7
		A2C3832900033		0 - 90 mph	pulses	65265	84	0xA7
		A2C3832910034	BLUE	0 - 120 Km/h	pulses	65265	84	0xA7
		A2C3832920034		0 - 140 mph	pulses	65265	84	0xA7
		A2C3832930034		0 - 160 mph	pulses	65265	84	0xA7
		A2C3832940034		0 - 200 Km/h	pulses	65265	84	0xA7
		A2C3832950034		0 - 300 Km/h	pulses	65265	84	0xA7
		A2C3832880034		0 - 30 mph	pulses	65265	84	0xA7
		A2C3832890034		0 - 60 Km/h	pulses	65265	84	0xA7
		A2C3832900034		0 - 90 mph	pulses	65265	84	0xA7

### 80/85mm TACHOMETERS:



Single pack	Bulk (10 pcs)	Aftermarket pack	Backlight color	Scale (min-max-units)	Analogue Input type	CAN PGN	CAN SPN	CAN Source Address
A2C3832960001	A2C3832960010		WHITE	0 - 2000 rpm	pulses	61444	190	0x17
A2C3832970001	A2C3832970010			0 - 2500 rpm	pulses	61444	190	0x17
A2C3832980001	A2C3832980010			0 - 3000 rpm	pulses	61444	190	0x17
A2C3832990001	A2C3832990010			0 - 4000 rpm	pulses	61444	190	0x17
A2C3833000001	A2C3833000010			0 - 5000 rpm	pulses	61444	190	0x17
A2C3833010001	A2C3833010010			0 - 6000 rpm	pulses	61444	190	0x17
A2C3833020001	A2C3833020010			0 - 8000 rpm	pulses	61444	190	0x17
		A2C3832960031		AMBER	0 - 2000 rpm	pulses	61444	190
		A2C3832970031	0 - 2500 rpm		pulses	61444	190	0x17
		A2C3832980031	0 - 3000 rpm		pulses	61444	190	0x17
		A2C3832990031	0 - 4000 rpm		pulses	61444	190	0x17
		A2C3833000031	0 - 5000 rpm		pulses	61444	190	0x17
		A2C3833010031	0 - 6000 rpm		pulses	61444	190	0x17
		A2C3833020031	0 - 8000 rpm		pulses	61444	190	0x17



### 80/85mm TACHOMETERS:

Single pack	Bulk (10 pcs)	Aftermarket pack	Backlight color	Scale (min-max-units)	Analogue Input type	CAN PGN	CAN SPN	CAN Source Address
		A2C3832960032	RED	0 - 2000 rpm	pulses	61444	190	0x17
		A2C3832970032		0 - 2500 rpm	pulses	61444	190	0x17
		A2C3832980032		0 - 3000 rpm	pulses	61444	190	0x17
		A2C3832990032		0 - 4000 rpm	pulses	61444	190	0x17
		A2C3833000032		0 - 5000 rpm	pulses	61444	190	0x17
		A2C3833010032		0 - 6000 rpm	pulses	61444	190	0x17
		A2C3833020032		0 - 8000 rpm	pulses	61444	190	0x17
		A2C3832960033	GREEN	0 - 2000 rpm	pulses	61444	190	0x17
		A2C3832970033		0 - 2500 rpm	pulses	61444	190	0x17
		A2C3832980033		0 - 3000 rpm	pulses	61444	190	0x17
		A2C3832990033		0 - 4000 rpm	pulses	61444	190	0x17
		A2C3833000033		0 - 5000 rpm	pulses	61444	190	0x17
		A2C3833010033		0 - 6000 rpm	pulses	61444	190	0x17
		A2C3833020033		0 - 8000 rpm	pulses	61444	190	0x17
		A2C3832960034	BLUE	0 - 2000 rpm	pulses	61444	190	0x17
		A2C3832970034		0 - 2500 rpm	pulses	61444	190	0x17
		A2C3832980034		0 - 3000 rpm	pulses	61444	190	0x17
		A2C3832990034		0 - 4000 rpm	pulses	61444	190	0x17
		A2C3833000034		0 - 5000 rpm	pulses	61444	190	0x17
		A2C3833010034		0 - 6000 rpm	pulses	61444	190	0x17
		A2C3833020034		0 - 8000 rpm	pulses	61444	190	0x17

### 100 mm SPEEDOMETERS:



Single pack	Bulk (10 pcs)	Aftermarket pack	Backlight color	Scale (min-max-units)	Analogue Input type	CAN PGN	CAN SPN	CAN Source Address
A2C3832860001	A2C3832860010		WHITE	0 - 120 Km/h	pulses	65265	84	0xA7
A2C3832850001	A2C3832850010			0 - 140 mph	pulses	65265	84	0xA7
A2C3832840001	A2C3832840010			0 - 200 Km/h	pulses	65265	84	0xA7
A2C3832830001	A2C3832830010			0 - 300 Km/h	pulses	65265	84	0xA7
A2C3832870001	A2C3832870010			0 - 90 mph	pulses	65265	84	0xA7
		A2C3832860031	AMBER	0 - 120 Km/h	pulses	65265	84	0xA7
		A2C3832850031		0 - 140 mph	pulses	65265	84	0xA7
		A2C3832840031		0 - 200 Km/h	pulses	65265	84	0xA7
		A2C3832830031		0 - 300 Km/h	pulses	65265	84	0xA7
		A2C3832870031		0 - 90 mph	pulses	65265	84	0xA7
		A2C3832860032	RED	0 - 120 Km/h	pulses	65265	84	0xA7
		A2C3832850032		0 - 140 mph	pulses	65265	84	0xA7
		A2C3832840032		0 - 200 Km/h	pulses	65265	84	0xA7
		A2C3832830032		0 - 300 Km/h	pulses	65265	84	0xA7
		A2C3832870032		0 - 90 mph	pulses	65265	84	0xA7

100 mm SPEEDOMETERS:

Single pack	Bulk (10 pcs)	Aftermarket pack	Backlight color	Scale (min-max- units)	Analogue Input type	CAN PGN	CAN SPN	CAN Source Address
		A2C3832860033	GREEN	0 - 120 Km/h	pulses	65265	84	0xA7
		A2C3832850033		0 - 140 mph	pulses	65265	84	0xA7
		A2C3832840033		0 - 200 Km/h	pulses	65265	84	0xA7
		A2C3832830033		0 - 300 Km/h	pulses	65265	84	0xA7
		A2C3832870033		0 - 90 mph	pulses	65265	84	0xA7
		A2C3832860034	BLUE	0 - 120 Km/h	pulses	65265	84	0xA7
		A2C3832850034		0 - 140 mph	pulses	65265	84	0xA7
		A2C3832840034		0 - 200 Km/h	pulses	65265	84	0xA7
		A2C3832830034		0 - 300 Km/h	pulses	65265	84	0xA7
		A2C3832870034		0 - 90 mph	pulses	65265	84	0xA7

100 mm TACHOMETERS



Single pack	Bulk (10 pcs)	Aftermarket pack	Backlight color	Scale (min-max- units)	Analogue Input type	CAN PGN	CAN SPN	CAN Source Address
A2C3832820001	A2C3832820010		WHITE	0 - 2500 rpm	pulses	61444	190	0x17
A2C3832810001	A2C3832810010			0 - 3000 rpm	pulses	61444	190	0x17
A2C3832800001	A2C3832800010			0 - 4000 rpm	pulses	61444	190	0x17
A2C3832790001	A2C3832790010			0 - 5000 rpm	pulses	61444	190	0x17
		A2C3832820031	AMBER	0 - 2500 rpm	pulses	61444	190	0x17
		A2C3832810031		0 - 3000 rpm	pulses	61444	190	0x17
		A2C3832800031		0 - 4000 rpm	pulses	61444	190	0x17
		A2C3832790031		0 - 5000 rpm	pulses	61444	190	0x17
		A2C3832820032	RED	0 - 2500 rpm	pulses	61444	190	0x17
		A2C3832810032		0 - 3000 rpm	pulses	61444	190	0x17
		A2C3832800032		0 - 4000 rpm	pulses	61444	190	0x17
		A2C3832790032		0 - 5000 rpm	pulses	61444	190	0x17
		A2C3832820033	GREEN	0 - 2500 rpm	pulses	61444	190	0x17
		A2C3832810033		0 - 3000 rpm	pulses	61444	190	0x17
		A2C3832800033		0 - 4000 rpm	pulses	61444	190	0x17
		A2C3832790033		0 - 5000 rpm	pulses	61444	190	0x17
		A2C3832820034	BLUE	0 - 2500 rpm	pulses	61444	190	0x17
		A2C3832810034		0 - 3000 rpm	pulses	61444	190	0x17
		A2C3832800034		0 - 4000 rpm	pulses	61444	190	0x17
		A2C3832790034		0 - 5000 rpm	pulses	61444	190	0x17

52mm TACHOMETERS



Single pack	Bulk (25 pcs)	Aftermarket pack	Backlight color	Scale (min-max- units)	Analogue input range	CAN PGN	CAN SPN	CAN Source Address
A2C3833030001	A2C3833030025	n.d.	WHITE	0 - 4000 rpm	n.d.	61444	190	0x17

### 52 mm AMMETERS:



Single pack	Bulk (25 pcs)	Aftermarket pack	Backlight color	Scale (min-max-units)	Analogue input range	CAN PGN	CAN SPN	CAN Source Address
A2C3833090001	A2C3833090025	A2C3833090030	WHITE	-30 +30 AMP	-60 +60 mV	65271	114	0x29
A2C3833080001	A2C3833080025	A2C3833080030		-60 +60 AMP	-60 +60 mV	65271	114	0x29
A2C3833070001	A2C3833070025	A2C3833070030		-100 +100 AMP	-60 +60 mV	65271	114	0x29
A2C3833060001	A2C3833060025	A2C3833060030		-150 +150 AMP	-60 +60 mV	65271	114	0x29
		A2C3833090031	AMBER	-30 +30 AMP	-60 +60 mV	65271	114	0x29
		A2C3833080031		-60 +60 AMP	-60 +60 mV	65271	114	0x29
		A2C3833070031		-100 +100 AMP	-60 +60 mV	65271	114	0x29
		A2C3833060031		-150 +150 AMP	-60 +60 mV	65271	114	0x29
		A2C3833090032	RED	-30 +30 AMP	-60 +60 mV	65271	114	0x29
		A2C3833080032		-60 +60 AMP	-60 +60 mV	65271	114	0x29
		A2C3833070032		-100 +100 AMP	-60 +60 mV	65271	114	0x29
		A2C3833060032		-150 +150 AMP	-60 +60 mV	65271	114	0x29
		A2C3833090033	GREEN	-30 +30 AMP	-60 +60 mV	65271	114	0x29
		A2C3833080033		-60 +60 AMP	-60 +60 mV	65271	114	0x29
		A2C3833070033		-100 +100 AMP	-60 +60 mV	65271	114	0x29
		A2C3833060033		-150 +150 AMP	-60 +60 mV	65271	114	0x29
		A2C3833090034	BLUE	-30 +30 AMP	-60 +60 mV	65271	114	0x29
		A2C3833080034		-60 +60 AMP	-60 +60 mV	65271	114	0x29
		A2C3833070034		-100 +100 AMP	-60 +60 mV	65271	114	0x29
		A2C3833060034		-150 +150 AMP	-60 +60 mV	65271	114	0x29

### 52 mm AdBLUE CONCENTRATION:



DEF



Single pack	Bulk (25 pcs)	Aftermarket pack	Backlight color	Scale (min-max-units)	Analogue input range	CAN PGN	CAN SPN	CAN Source Address
A2C3832760001	A2C3832760025	n.d.	WHITE	0 - 100%	n.d.	64923	3516	0x27

### 52 mm AdBLUE LEVEL :



DEF



Single pack	Bulk (25 pcs)	Aftermarket pack	Backlight color	Scale (min-max-units)	Analogue input range	CAN PGN	CAN SPN	CAN Source Address
A2C3833550001	A2C3833550025	A2C3833550030	WHITE	0 - 1/1	3 - 180 Ω	65110	1761	0x27
A2C3832750001	A2C3832750025	A2C3832750030		E - F	240 - 33,5 Ω	65110	1761	0x27

## 52 mm AdBLUE LEVEL

Single pack	Bulk (25 pcs)	Aftermarket pack	Backlight color	Scale (min-max- units)	Analogue input range	CAN PGN	CAN SPN	CAN Source Address
		A2C3833550031	AMBER	0 - 1/1	3 - 180 Ω	65110	1761	0x27
		A2C3832750031		E - F	240 - 33,5 Ω	65110	1761	0x27
		A2C3833550032	RED	0 - 1/1	3 - 180 Ω	65110	1761	0x27
		A2C3832750032		E - F	240 - 33,5 Ω	65110	1761	0x27
		A2C3833550033	GREEN	0 - 1/1	3 - 180 Ω	65110	1761	0x27
		A2C3832750033		E - F	240 - 33,5 Ω	65110	1761	0x27
		A2C3833550034	BLUE	0 - 1/1	3 - 180 Ω	65110	1761	0x27
		A2C3832750034		E - F	240 - 33,5 Ω	65110	1761	0x27

## 52 mm FUEL LEVEL:



Single pack	Bulk (25 pcs)	Aftermarket pack	Backlight color	Scale (min-max- units)	Analogue input range	CAN PGN	CAN SPN	CAN Source Address
A2C3833100001	A2C3833100025	A2C3833100030	WHITE	0 - 1	3 - 180 Ω	65276	96	0x27
A2C3833110001	A2C3833110025	A2C3833110030		0 - 1	90 - 5 Ω	65276	96	0x27
A2C3833120001	A2C3833120025	A2C3833120030		E - F	3 - 180 Ω	65276	96	0x27
A2C3833130001	A2C3833130025	A2C3833130030		E - F	240 - 33,5 Ω	65276	96	0x27
A2C3833140001	A2C3833140025	A2C3833140030		E - F	0 - 90 Ω	65276	96	0x27
A2C3833150001	A2C3833150025	A2C3833150030		E - F	90 - 5 Ω	65276	96	0x27
A2C3916300001	A2C3916300025	A2C3916300030		E - F	0 - 5V	65276	96	0x27
		A2C3833100031	AMBER	0 - 1	3 - 180 Ω	65276	96	0x27
		A2C3833110031		0 - 1	90 - 5 Ω	65276	96	0x27
		A2C3833120031		E - F	3 - 180 Ω	65276	96	0x27
		A2C3833130031		E - F	240 - 33,5 Ω	65276	96	0x27
		A2C3833140031		E - F	0 - 90 Ω	65276	96	0x27
		A2C3833150031		E - F	90 - 5 Ω	65276	96	0x27
		A2C3916300031		E - F	0 - 5V	65276	96	0x27
		A2C3833100032	RED	0 - 1	3 - 180 Ω	65276	96	0x27
		A2C3833110032		0 - 1	90 - 5 Ω	65276	96	0x27
		A2C3833120032		E - F	3 - 180 Ω	65276	96	0x27
		A2C3833130032		E - F	240 - 33,5 Ω	65276	96	0x27
		A2C3833140032		E - F	0 - 90 Ω	65276	96	0x27
		A2C3833150032		E - F	90 - 5 Ω	65276	96	0x27
		A2C3916300032		E - F	0 - 5V	65276	96	0x27
		A2C3833100033	GREEN	0 - 1	3 - 180 Ω	65276	96	0x27
		A2C3833110033		0 - 1	90 - 5 Ω	65276	96	0x27
		A2C3833120033		E - F	3 - 180 Ω	65276	96	0x27
		A2C3833130033		E - F	240 - 33,5 Ω	65276	96	0x27
		A2C3833140033		E - F	0 - 90 Ω	65276	96	0x27
		A2C3833150033		E - F	90 - 5 Ω	65276	96	0x27
		A2C3916300033		E - F	0 - 5V	65276	96	0x27
		A2C3833100034	BLUE	0 - 1	3 - 180 Ω	65276	96	0x27
		A2C3833110034		0 - 1	90 - 5 Ω	65276	96	0x27
		A2C3833120034		E - F	3 - 180 Ω	65276	96	0x27
		A2C3833130034		E - F	240 - 33,5 Ω	65276	96	0x27
		A2C3833140034		E - F	0 - 90 Ω	65276	96	0x27
		A2C3833150034		E - F	90 - 5 Ω	65276	96	0x27
		A2C3916300034		E - F	0 - 5V	65276	96	0x27

52 mm AIR PRESSURE (GENERIC):



Single pack	Bulk (25 pcs)	Aftermarket pack	Backlight color	Scale (min-max-units)	Analogue input range	CAN PGN	CAN SPN	CAN Source Address
A2C3833440001	A2C3833440025	A2C3833440030	WHITE	0 - 150 psi	10 - 184 Ω		n.d.	
		A2C3833440031	AMBER	0 - 150 psi	10 - 184 Ω		n.d.	
		A2C3833440032	RED	0 - 150 psi	10 - 184 Ω		n.d.	
		A2C3833440033	GREEN	0 - 150 psi	10 - 184 Ω		n.d.	
		A2C3833440034	BLUE	0 - 150 psi	10 - 184 Ω		n.d.	

52 mm BRAKE PRESSURE:



Single pack	Bulk (25 pcs)	Aftermarket pack	Backlight color	Scale (min-max-units)	Analogue input range	CAN PGN	CAN SPN	CAN Source Address
A2C3833450001	A2C3833450025	A2C3833450030	WHITE	0 - 10 bar	10 - 184 Ω	65274	117	0x25
A2C3832710001	A2C3832710025	A2C3832710030		0 - 16 bar	0.5 - 4.5 V	65274	117	0x25
A2C3833480001	A2C3833480025	A2C3833480030		0 - 150 psi	10 - 184 Ω	65274	117	0x25
A2C3832730001	A2C3832730025	A2C3832730030		0 - 250 psi	0.5 - 4.5 V	65274	117	0x25
		A2C3833450031	AMBER	0 - 10 bar	10 - 184 Ω	65274	117	0x25
		A2C3832710031		0 - 16 bar	0.5 - 4.5 V	65274	117	0x25
		A2C3833480031		0 - 150 psi	10 - 184 Ω	65274	117	0x25
		A2C3832730031		0 - 250 psi	0.5 - 4.5 V	65274	117	0x25
		A2C3833450032	RED	0 - 10 bar	10 - 184 Ω	65274	117	0x25
		A2C3832710032		0 - 16 bar	0.5 - 4.5 V	65274	117	0x25
		A2C3833480032		0 - 150 psi	10 - 184 Ω	65274	117	0x25
		A2C3832730032		0 - 250 psi	0.5 - 4.5 V	65274	117	0x25
		A2C3833450033	GREEN	0 - 10 bar	10 - 184 Ω	65274	117	0x25
		A2C3832710033		0 - 16 bar	0.5 - 4.5 V	65274	117	0x25
		A2C3833480033		0 - 150 psi	10 - 184 Ω	65274	117	0x25
		A2C3832730033		0 - 250 psi	0.5 - 4.5 V	65274	117	0x25
		A2C3833450034	BLUE	0 - 10 bar	10 - 184 Ω	65274	117	0x25
		A2C3832710034		0 - 16 bar	0.5 - 4.5 V	65274	117	0x25
		A2C3833480034		0 - 150 psi	10 - 184 Ω	65274	117	0x25
		A2C3832730034		0 - 250 psi	0.5 - 4.5 V	65274	117	0x25

52 mm TRANSMISSION OIL PRESSURE:



Single pack	Bulk (25 pcs)	Aftermarket pack	Backlight color	Scale (min-max- units)	Analogue input range	CAN PGN	CAN SPN	CAN Source Address
A2C3833460001	A2C3833460025	A2C3833460030	WHITE	0 - 25 bar	10 - 184 Ω	65272	127	0x23
A2C3832720001	A2C3832720025	A2C3832720030		0 - 30 bar	0.5 - 4.5 V	65272	127	0x23
A2C3833500001	A2C3833350025	A2C3833350030		0 - 400 psi	10 - 184 Ω	65272	127	0x23
A2C3832740001	A2C3832740025	A2C3832740030		0 - 500 psi	0.5 - 4.5 V	65272	127	0x23
		A2C3833460031	AMBER	0 - 25 bar	10 - 184 Ω	65272	127	0x23
		A2C3832720031		0 - 30 bar	0.5 - 4.5 V	65272	127	0x23
		A2C3833350031		0 - 400 psi	10 - 184 Ω	65272	127	0x23
		A2C3832740031		0 - 500 psi	0.5 - 4.5 V	65272	127	0x23
		A2C3833460032	RED	0 - 25 bar	10 - 184 Ω	65272	127	0x23
		A2C3832720032		0 - 30 bar	0.5 - 4.5 V	65272	127	0x23
		A2C3833350032		0 - 400 psi	10 - 184 Ω	65272	127	0x23
		A2C3832740032		0 - 500 psi	0.5 - 4.5 V	65272	127	0x23
		A2C3833460033	GREEN	0 - 25 bar	10 - 184 Ω	65272	127	0x23
		A2C3832720033		0 - 30 bar	0.5 - 4.5 V	65272	127	0x23
		A2C3833350033		0 - 400 psi	10 - 184 Ω	65272	127	0x23
		A2C3832740033		0 - 500 psi	0.5 - 4.5 V	65272	127	0x23
		A2C3833460034	BLUE	0 - 25 bar	10 - 184 Ω	65272	127	0x23
		A2C3832720034		0 - 30 bar	0.5 - 4.5 V	65272	127	0x23
		A2C3833350034		0 - 400 psi	10 - 184 Ω	65272	127	0x23
		A2C3832740034		0 - 500 psi	0.5 - 4.5 V	65272	127	0x23

52 mm ENGINE OIL PRESSURE:



Single pack	Bulk (25 pcs)	Aftermarket pack	Backlight color	Scale (min-max- units)	Analogue input range	CAN PGN	CAN SPN	CAN Source Address
A2C3833170001	A2C3833170025	A2C3833170030	WHITE	0 - 10 bar	10 - 184 Ω	65263	100	0x22
A2C3832690001	A2C3832690025	A2C3832690030		0 - 10 bar	0.5 - 4.5 V	65263	100	0x22
A2C3833240001	A2C3833240025	A2C3833240030		0 - 150 psi "OIL"	10 - 184 Ω	65263	100	0x22
A2C3833300001	A2C3833300025	A2C3833300030		0 - 150 psi	10 - 184 Ω	65263	100	0x22
A2C3832700001	A2C3832700025	A2C3832700030		0 - 150 psi	0.5 - 4.5 V	65263	100	0x22
A2C3833160001	A2C3833160025	A2C3833160030		0 - 5 bar	10 - 184 Ω	65263	100	0x22
A2C3833230001	A2C3833230025	A2C3833230030		0 - 80 psi	240 - 33,5 Ω	65263	100	0x22
A2C3833190030	A2C3833190025	A2C3833190030		0 - 80 psi	10 - 184 Ω	65263	100	0x22
		A2C3833170031	AMBER	0 - 10 bar	10 - 184 Ω	65263	100	0x22
		A2C3832690031		0 - 10 bar	0.5 - 4.5 V	65263	100	0x22
		A2C3833240031		0 - 150 psi "OIL"	10 - 184 Ω	65263	100	0x22
		A2C3833300031		0 - 150 psi	10 - 184 Ω	65263	100	0x22
		A2C3832700031		0 - 150 psi	0.5 - 4.5 V	65263	100	0x22
		A2C3833160031		0 - 5 bar	10 - 184 Ω	65263	100	0x22
		A2C3833230031		0 - 80 psi	240 - 33,5 Ω	65263	100	0x22
		A2C3833190031		0 - 80 psi	10 - 184 Ω	65263	100	0x22



## 52 mm ENGINE OIL PRESSURE:

Single pack	Bulk (25 pcs)	Aftermarket pack	Backlight color	Scale (min-max-units)	Analogue input range	CAN PGN	CAN SPN	CAN Source Address
		A2C3833170032	RED	0 - 10 bar	10 - 184 Ω	65263	100	0x22
		A2C3832690032		0 - 10 bar	0.5 - 4.5 V	65263	100	0x22
		A2C3833240032		0 - 150 psi "OIL"	10 - 184 Ω	65263	100	0x22
		A2C3833300032		0 - 150 psi	10 - 184 Ω	65263	100	0x22
		A2C3832700032		0 - 150 psi	0.5 - 4.5 V	65263	100	0x22
		A2C3833160032		0 - 5 bar	10 - 184 Ω	65263	100	0x22
		A2C3833230032		0 - 80 psi	240 - 33,5 Ω	65263	100	0x22
		A2C3833190032		0 - 80 psi	10 - 184 Ω	65263	100	0x22
		A2C3833170033	GREEN	0 - 10 bar	10 - 184 Ω	65263	100	0x22
		A2C3832690033		0 - 10 bar	0.5 - 4.5 V	65263	100	0x22
		A2C3833240033		0 - 150 psi "OIL"	10 - 184 Ω	65263	100	0x22
		A2C3833300033		0 - 150 psi	10 - 184 Ω	65263	100	0x22
		A2C3832700033		0 - 150 psi	0.5 - 4.5 V	65263	100	0x22
		A2C3833160033		0 - 5 bar	10 - 184 Ω	65263	100	0x22
		A2C3833230033		0 - 80 psi	240 - 33,5 Ω	65263	100	0x22
		A2C3833190033		0 - 80 psi	10 - 184 Ω	65263	100	0x22
		A2C3833170034	BLUE	0 - 10 bar	10 - 184 Ω	65263	100	0x22
		A2C3832690034		0 - 10 bar	0.5 - 4.5 V	65263	100	0x22
		A2C3833240034		0 - 150 psi "OIL"	10 - 184 Ω	65263	100	0x22
		A2C3833300034		0 - 150 psi	10 - 184 Ω	65263	100	0x22
		A2C3832700034		0 - 150 psi	0.5 - 4.5 V	65263	100	0x22
		A2C3833160034		0 - 5 bar	10 - 184 Ω	65263	100	0x22
		A2C3833230034		0 - 80 psi	240 - 33,5 Ω	65263	100	0x22
		A2C3833190034		0 - 80 psi	10 - 184 Ω	65263	100	0x22

## 52 mm TURBO PRESSURE:



Single pack	Bulk (25 pcs)	Aftermarket pack	Backlight color	Scale (min-max-units)	Analogue input range	CAN PGN	CAN SPN	CAN Source Address
A2C3833490001	A2C3833490025	A2C3833490030	WHITE	0 - 2 bar	10 - 184 Ω	65270	102	0x24
A2C3833470001	A2C3833470025	A2C3833470030		0 - 60 psi	10 - 184 Ω	65270	102	0x24
		A2C3833490031	AMBER	0 - 2 bar	10 - 184 Ω	65270	102	0x24
		A2C3833470031		0 - 60 psi	10 - 184 Ω	65270	102	0x24
		A2C3833490032	RED	0 - 2 bar	10 - 184 Ω	65270	102	0x24
		A2C3833470032		0 - 60 psi	10 - 184 Ω	65270	102	0x24
		A2C3833490033	GREEN	0 - 2 bar	10 - 184 Ω	65270	102	0x24
		A2C3833470033		0 - 60 psi	10 - 184 Ω	65270	102	0x24
		A2C3833490034	BLUE	0 - 2 bar	10 - 184 Ω	65270	102	0x24
		A2C3833470034		0 - 60 psi	10 - 184 Ω	65270	102	0x24



52 mm EXHAUST GAS TEMPERATURE:



Single pack	Bulk (25 pcs)	Aftermarket pack	Backlight color	Scale (min-max-units)	Analogue input range	CAN PGN	CAN SPN	CAN Source Address
A2C3833040001	A2C3833040025	A2C3833040030	WHITE	0 - 1000 °C	4,1 - 37,7 mV	65270	173	0x30
A2C3833050001	A2C3833050025	A2C3833050030		0 - 2000 °C	4,1 - 37,7 mV	65270	173	0x30
		A2C3833040031	AMBER	0 - 1000 °C	4,1 - 37,7 mV	65270	173	0x30
		A2C3833050031		0 - 2000 °C	4,1 - 37,7 mV	65270	173	0x30
		A2C3833040032	RED	0 - 1000 °C	4,1 - 37,7 mV	65270	173	0x30
		A2C3833050032		0 - 2000 °C	4,1 - 37,7 mV	65270	173	0x30
		A2C3833040033	GREEN	0 - 1000 °C	4,1 - 37,7 mV	65270	173	0x30
		A2C3833050033		0 - 2000 °C	4,1 - 37,7 mV	65270	173	0x30
		A2C3833040034	BLUE	0 - 1000 °C	4,1 - 37,7 mV	65270	173	0x30
		A2C3833050034		0 - 2000 °C	4,1 - 37,7 mV	65270	173	0x30

52 mm CYLINDER TEMPERATURE:



Single pack	Bulk (25 pcs)	Aftermarket pack	Backlight color	Scale (min-max-units)	Analogue input range	CAN PGN	CAN SPN	CAN Source Address
A2C3833520001	A2C3833520025		WHITE	60 - 200 °C	482,5- 14,3 Ω			n.d.
A2C3833530001	A2C3833530025			150 - 400 °C	482,5- 14,3 Ω			n.d.
		A2C3833520031	AMBER	60 - 200 °C	482,5- 14,3 Ω			n.d.
		A2C3833530031		150 - 400 °C	482,5- 14,3 Ω			n.d.
		A2C3833520032	RED	60 - 200 °C	482,5- 14,3 Ω			n.d.
		A2C3833530032		150 - 400 °C	482,5- 14,3 Ω			n.d.
		A2C3833520033	GREEN	60 - 200 °C	482,5- 14,3 Ω			n.d.
		A2C3833530033		150 - 400 °C	482,5- 14,3 Ω			n.d.
		A2C3833520034	BLUE	60 - 200 °C	482,5- 14,3 Ω			n.d.
		A2C3833530034		150 - 400 °C	482,5- 14,3 Ω			n.d.

52 mm HYDRAULIC OIL TEMPERATURE:



Single pack	Bulk (25 pcs)	Aftermarket pack	Backlight color	Scale (min-max-units)	Analogue input range	CAN PGN	CAN SPN	CAN Source Address
A2C3833510001	A2C3833510025		WHITE	60 - 120 °C	287,4 - 22,7 Ω	65128	1638	0x21
A2C3916310001	A2C3916310025			0 - 250 °F	287,4 - 22,7 Ω	65128	1638	0x21
		A2C3833510031	AMBER	60 - 120 °C	287,4 - 22,7 Ω	65128	1638	0x21
		A2C3916310031		0 - 250 °F	287,4 - 22,7 Ω	65128	1638	0x21
		A2C3833510032	RED	60 - 120 °C	287,4 - 22,7 Ω	65128	1638	0x21
		A2C3916310032		0 - 250 °F	287,4 - 22,7 Ω	65128	1638	0x21

52 mm HYDRAULIC OIL PRESSURE:

Single pack	Bulk (25 pcs)	Aftermarket pack	Backlight color	Scale (min-max-units)	Analogue input range	CAN PGN	CAN SPN	CAN Source Address
		A2C3833510033	GREEN	60 - 120 °C	287,4 - 22,7 Ω	65128	1638	0x21
		A2C3916310033		0 - 250 °F	287,4 - 22,7 Ω	65128	1638	0x21
		A2C3833510034	BLUE	60 - 120 °C	287,4 - 22,7 Ω	65128	1638	0x21
		A2C3916310034		0 - 250 °F	287,4 - 22,7 Ω	65128	1638	0x21

52 mm ENGINE OIL TEMPERATURE:





Single pack	Bulk (25 pcs)	Aftermarket pack	Backlight color	Scale (min-max-units) - Symbol	Analogue input range	CAN PGN	CAN SPN	CAN Source Address
A2C3833380001	A2C3833380025		WHITE	50 - 150 °C	322,8 - 18,6 Ω	65262	175	0x19
A2C3833390001	A2C3833390025			50 - 150 °C	322,8 - 18,6 Ω	65262	175	0x19
A2C3833410001	A2C3833410025			100 - 300 °F	322,8 - 18,6 Ω	65262	175	0x19
		A2C3833380031	AMBER	50 - 150 °C	322,8 - 18,6 Ω	65262	175	0x19
		A2C3833390031		50 - 150 °C	322,8 - 18,6 Ω	65262	175	0x19
		A2C3833410031		100 - 300 °F	322,8 - 18,6 Ω	65262	175	0x19
		A2C3833380032	RED	50 - 150 °C	322,8 - 18,6 Ω	65262	175	0x19
		A2C3833390032		50 - 150 °C	322,8 - 18,6 Ω	65262	175	0x19
		A2C3833410032		100 - 300 °F	322,8 - 18,6 Ω	65262	175	0x19
		A2C3833380033	GREEN	50 - 150 °C	322,8 - 18,6 Ω	65262	175	0x19
		A2C3833390033		50 - 150 °C	322,8 - 18,6 Ω	65262	175	0x19
		A2C3833410033		100 - 300 °F	322,8 - 18,6 Ω	65262	175	0x19
		A2C3833380034	BLUE	50 - 150 °C	322,8 - 18,6 Ω	65262	175	0x19
		A2C3833390034		50 - 150 °C	322,8 - 18,6 Ω	65262	175	0x19
		A2C3833410034		100 - 300 °F	322,8 - 18,6 Ω	65262	175	0x19

52 mm ENGINE COOLANT TEMPERATURE:



Single pack	Bulk (25 pcs)	Aftermarket pack	Backlight color	Scale (min-max-units)	Analogue input range	CAN PGN	CAN SPN	CAN Source Address
A2C3833320001	A2C3833320025		WHITE	40 - 120 °C	287,4 - 22,7 Ω	65262	110	0x18
A2C3833330001	A2C3833330025			40 - 120 °C	287,4 - 22,7 Ω	65262	110	0x18
A2C3833340001	A2C3833340025			100 - 250 °F	450 - 30 Ω	65262	110	0x18
A2C3833350001	A2C3833350001			100 - 250 °F	287,4 - 22,7 Ω	65262	110	0x18
		A2C3833320031	AMBER	40 - 120 °C	287,4 - 22,7 Ω	65262	110	0x18
		A2C3833330031		40 - 120 °C	287,4 - 22,7 Ω	65262	110	0x18
		A2C3833340031		100 - 250 °F	450 - 30 Ω	65262	110	0x18
		A2C3833350031		100 - 250 °F	287,4 - 22,7 Ω	65262	110	0x18
		A2C3833320032	RED	40 - 120 °C	287,4 - 22,7 Ω	65262	110	0x18
		A2C3833330032		40 - 120 °C	287,4 - 22,7 Ω	65262	110	0x18
		A2C3833340032		100 - 250 °F	450 - 30 Ω	65262	110	0x18
		A2C3833350032		100 - 250 °F	287,4 - 22,7 Ω	65262	110	0x18

**52 mm ENGINE COOLANT TEMPERATURE:**

Single pack	Bulk (25 pcs)	Aftermarket pack	Backlight color	Scale (min-max- units)	Analogue input range	CAN PGN	CAN SPN	CAN Source Address
		A2C3833320033	GREEN	40 - 120 °C	287,4 - 22,7 Ω	65262	110	0x18
		A2C3833330033		40 - 120 °C 	287,4 - 22,7 Ω	65262	110	0x18
		A2C3833340033		100 - 250 °F	450 - 30 Ω	65262	110	0x18
		A2C3833350033		100 - 250 °F	287,4 - 22,7 Ω	65262	110	0x18
		A2C3833320034	BLUE	40 - 120 °C	287,4 - 22,7 Ω	65262	110	0x18
		A2C3833330034		40 - 120 °C 	287,4 - 22,7 Ω	65262	110	0x18
		A2C3833340034		100 - 250 °F	450 - 30 Ω	65262	110	0x18
		A2C3833350034		100 - 250 °F	287,4 - 22,7 Ω	65262	110	0x18

**52 mm VOLTMETER:**



Single pack	Bulk (25 pcs)	Aftermarket pack	Backlight color	Scale (min-max- units)	Analogue input range	CAN PGN	CAN SPN	CAN Source Address
A2C3832770001	A2C3832770025		WHITE	8 - 16 V	n.d.	65271	168	0x28
A2C3832780001	A2C3832780025			16 - 32 V	n.d.	65271	168	0x28
		A2C3832770031	AMBER	8 - 16 V	n.d.	65271	168	0x28
		A2C3832780031		16 - 32 V	n.d.	65271	168	0x28
		A2C3832770032	RED	8 - 16 V	n.d.	65271	168	0x28
		A2C3832780032		16 - 32 V	n.d.	65271	168	0x28
		A2C3832770033	GREEN	8 - 16 V	n.d.	65271	168	0x28
		A2C3832780033		16 - 32 V	n.d.	65271	168	0x28
		A2C3832770034	BLUE	8 - 16 V	n.d.	65271	168	0x28
		A2C3832780034		16 - 32 V	n.d.	65271	168	0x28

**52 mm BRAKE PRESSURE 1:**



Single pack	Bulk (25 pcs)	Aftermarket pack	Backlight color	Scale (min-max- units)	Analogue input range	CAN PGN	CAN SPN	CAN Source Address
A2C1800310001	A2C1800310025		WHITE					
		A2C1800310031	AMBER	10 bar	0 - 5 V	65274	117	0x25
		A2C1800310032	RED	10 bar	0 - 5 V	65274	117	0x25
		A2C1800310033	GREEN	10 bar	0 - 5 V	65274	117	0x25
		A2C1800310034	BLUE	10 bar	0 - 5 V	65274	117	0x25

**52 mm BRAKE PRESSURE 2:**



Single pack	Bulk (25 pcs)	Aftermarket pack	Backlight color	Scale (min-max- units)	Analogue input range	CAN PGN	CAN SPN	CAN Source Address
A2C1800330001	A2C1800330025		WHITE					
		A2C1800330031	AMBER	10 bar	0 - 5 V	65274	117	0x25
		A2C1800330032	RED	10 bar	0 - 5 V	65274	117	0x25
		A2C1800330033	GREEN	10 bar	0 - 5 V	65274	117	0x25
		A2C1800330034	BLUE	10 bar	0 - 5 V	65274	117	0x25

**52 mm BRAKE PRESSURE P**



Single pack	Bulk (25 pcs)	Aftermarket pack	Backlight color	Scale (min-max- units)	Analogue input range	CAN PGN	CAN SPN	CAN Source Address
A2C1800340001	A2C1800340025		WHITE					
		A2C1800340031	AMBER	10 bar	0 - 5 V	65274	117	0x25
		A2C1800340032	RED	10 bar	0 - 5 V	65274	117	0x25
		A2C1800340033	GREEN	10 bar	0 - 5 V	65274	117	0x25
		A2C1800340034	BLUE	10 bar	0 - 5 V	65274	117	0x25

## Accessories and spare parts

Order number	Description
<b>Spare Parts</b>	
A2C10434200	Spinlock nut for 52mm gauges
A2C39712100	Spinlock nut for 80/85mm gauges
A2C10434100	Spinlock nut for 100mm gauges
<b>Adapter cables, connector and crimp contacts</b>	
2910000484200	Preassembled cable "SingleViu 8 pin cable"
2910000484300	Preassembled cable "SingleViu 12 pin cable"
<b>Assembly kits of connectors and corresponding crimp contacts</b>	
2910000954200	52mm gauges: "SingleViu 8 pin connector"
2910000954300	80/85 or 100mm gauges: "SingleViu 8 pin _ 12 pin connectors"
<b>Programming cable for configuration via Config Tool</b>	
2910000401700	Programming cable "SingleViu Programming/Test cable"
<b>Adapter cable for the electric connection to replace a gauge of the predecessor series</b>	
2910000301300	Adapter cable "SingleViu Adapter cable ViewLine 8 pin"
2910000301400	Adapter cable "SingleViu Adapter cable ViewLine 14 pin"
2910000301500	Adapter cable "SingleViu Adapter cable WWG"
2910000301600	Adapter cable "SingleViu Adapter cable CANcockpit"

## Free of charge SingleViu ConfigTool, Programming dongle and CAN Boxes

Please contact your VDO Partner. Product trainings by Continental may be scheduled on demand.

For presetting of two reserved parameters, odometer in speedometer gauges and EHC in tachometer gauges, a dongle is required. A user license must be signed before purchase, please contact your VDO Partner.

The CANcockpit dongle X11-602-000-015 and the ViewLine dongle A2C59515259 can be reused or ordered.

For CAN boxes of companies Vector or Peak-Systems and CAN termination resistance please contact them directly or their local distributor. See web pages [www.vector.com](http://www.vector.com) and [www.peak-system.com](http://www.peak-system.com).

To connect gauges during configuration via Config Tool, the programming cable may be used:

- Programming cable "SingleViu Programming/Test cable": part number 2910000401700

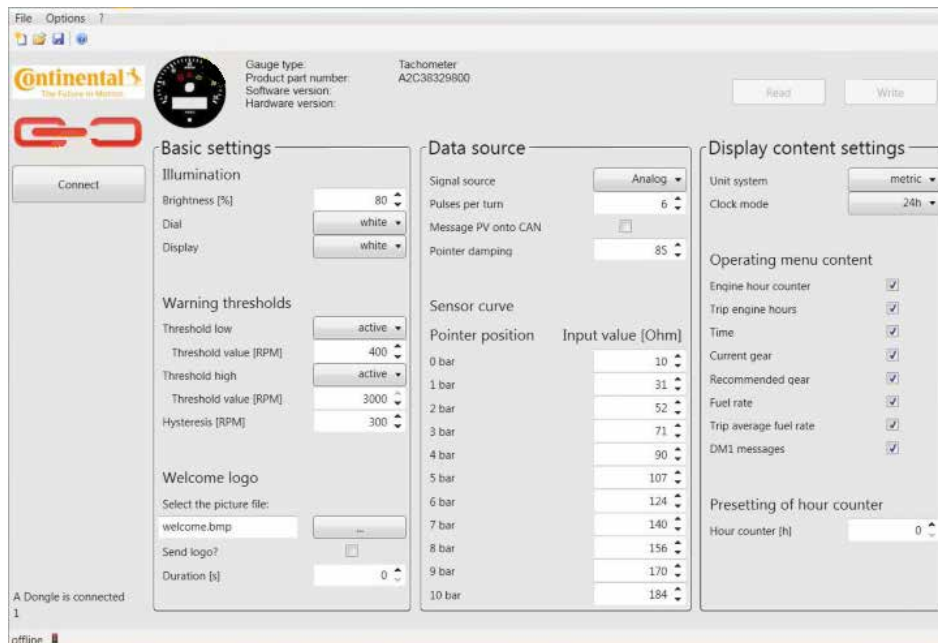

Exemplary illustration of the ConfigTool user mask. The set of items depend on the gauge variant

## 1.1.2 Cockpit International

### Robust gauges designed for heavy use conditions

Each instrument is supplied complete, ready to be mounted with lighting (except in specific cases). Detailed range below

- Black dials with white scale and ISO symbol
- Black triangular bezel
- Light diffusion
- Anti-reflective glass

- Power supply: 12 V (11 to 16 V) and/or 24 V (21,5 to 30 V).
- Operating temperature: from -30 to +85°C.
- Fixing by brackets or clamp ring
- Protection class: IP64.



#### Speedometers

- Analogue speed indication (pointer).
- Odometer and trip distance on LC Display
- 7-digit Odometer (up to 999 999.9).
- 5-digit trip distance (up to 9 999.9).
- Pulses/km configurable from 500 to 400 000 (calibration)
- Signal source: Hall, inductive sender or blocking oscillator sender
- Supplied with stud bolts
- Voltage supply: 12 V and 24 V.
- Black dial

Packing	Order number	Scale	Ø Installation	Voltage
<b>ELECTRONIC SPEEDOMETERS</b>				
10 pcs	437-035-001C	0 - 60 km/h	80 mm	12/24 V
single	437-035-001G	0 - 60 km/h	80 mm	12/24 V
10 pcs	437-035-002C	0 - 120 km/h	80 mm	12/24 V
single	437-035-002G	0 - 120 km/h	80 mm	12/24 V
10 pcs	437-035-003C	0 - 200 km/h	80 mm	12/24 V
single	437-035-003G	0 - 200 km/h	80 mm	12/24 V
6 pcs	437-025-002C	0 - 125 km/h	140 mm	12/24 V

## Electronic tachometers WITHOUT hourscounter

For petrol or diesel fuel engines

- Programmable for petrol engines (4, 6 or 8 cylinders) or diesel (“W” signal from the alternator).
- Supplied with brackets for stud bolts. The indicators can be also mounted using clamp ring (not included).
- Supply Voltage: see table below

Packing	Order number	Scale	Ø Installation	Voltage
<b>ELECTRONIC TACHOMETERS WITHOUT HOURS COUNTER</b>				
single	333-035-029G	0 - 4000 RPM	52 mm	12 V
10 pcs	333-035-017C	0 - 6000 RPM	52 mm	12 V
single	333-035-017G	0 - 6000 RPM	52 mm	12 V
single	333-035-018G	0 - 8000 RPM	52 mm	12 V
10 pcs	333-035-001C	0 - 3000 RPM	80 mm	12 V
single	333-035-001G	0 - 3000 RPM	80 mm	12 V
10 pcs	333-045-001C	0 - 3000 RPM	80 mm	24 V
single	333-045-001G	0 - 3000 RPM	80 mm	24 V
10 pcs	333-035-002C	0 - 4000 RPM	80 mm	12 V
single	333-035-002G	0 - 4000 RPM	80 mm	12 V
10 pcs	333-045-002C	0 - 4000 RPM	80 mm	24 V
single	333-045-002G	0 - 4000 RPM	80 mm	24 V
single	333-035-003G	0 - 7000 RPM	80 mm	12 V
10 pcs	333-035-022C	0 - 10000 RPM	80 mm	12 V
single	333-035-022G	0 - 10000 RPM	80 mm	12 V
single	333-055-001G	0 - 3000 RPM	100 mm	12 V
single	333-065-001G	0 - 3 000 RPM	100 mm	24 V

## Electronic tachometers WITH hourscounter

Programmable with all the combinations “x cylinders / x strokes”

- Analogue engine speed indication (RPM) .
- Digital display (LCD) with 7 characters for the hourscounter (up to 99 999.9 h).
- Signal sources: terminal W alternator, Hall sensors, blocking oscillators sensors, terminal 1 of the ignition coil.
- Supplied with brackets for stud bolts. The indicators can be also mounted using clamp ring (not included).
- Supply Voltage: see table below

Packing	Order number	Scale	Ø Installation	Voltage
<b>ELECTRONIC TACHOMETERS WITH HOURS COUNTER</b>				
single	333-035-010G	0 - 3000 RPM	80 mm	12/24 V
10 pcs	333-035-010C	0 - 3000 RPM	80 mm	12/24 V
single	333-035-011G	0 - 4000 RPM	80 mm	12/24 V
10 pcs	333-035-011C	0 - 4000 RPM	80 mm	12/24 V
10 pcs	333-035-014C	0 - 6000 RPM	80 mm	12/24 V
single	333-055-002G	0 - 3000 RPM	100 mm	12/24 V
10 pcs	333-055-002C	0 - 3000 RPM	100 mm	12/24 V

## Thermometers

For all the Industrial vehicles

- For the indication of engine oil, coolant, hydraulic oil and transmission oil temperature

Packing	Order number	Scale	Ø Installation	Voltage
<b>COOLANT TEMPERATURE WITH ISO SYMBOL</b>				
single	310-030-002G	40 – 120°C	52 mm	12 V
10 pcs	310-030-002C	40 – 120°C	52 mm	12 V
single	310-040-002G	40 – 120°C	52 mm	24 V
10 pcs	310-040-002C	40 – 120°C	52 mm	24 V
10 pcs	310-030-020C	40 – 120°C/100-250F°	52 mm	12 V
10 pcs	310-040-020C	40 – 120°C/100-250F°	52 mm	24 V
<b>ENGINE OIL TEMPERATURE WITH ISO SYMBOL</b>				
single	310-030-003G	50 – 150°C	52 mm	12 V
10 pcs	310-030-003C	50 – 150°C	52 mm	12 V
single	310-040-003G	50 – 150°C	52 mm	24 V
10 pcs	310-040-003C	50 – 150°C	52 mm	24 V
<b>HYDRAULIC OIL TEMPERATURE WITH ISO SYMBOL</b>				
single	310-030-013G	40 – 120°C	52 mm	12 V
10 pcs	310-030-013C	40 – 120°C	52 mm	12 V
single	310-040-013G	40 – 120°C	52 mm	24 V
10 pcs	310-040-013C	40 – 120°C	52 mm	24 V
<b>TEMPERATURE OF AIR-COOLED ENGINES WITHOUT ISO SYMBOL</b>				
single	310-030-004G	60 – 200°C	52 mm	12 V
10 pcs	310-030-004C	60 – 200°C	52 mm	12 V
single	310-040-004G	60 – 200°C	52 mm	24 V
10 pcs	310-040-004C	60 – 200°C	52 mm	24 V
<b>TRANSMISSION OIL TEMPERATURE WITH ISO SYMBOL</b>				
single	310-030-015G	50 – 150°C	52 mm	12 V
10 pcs	310-030-015C	50 – 150°C	52 mm	12 V
single	310-040-015G	50 – 150°C	52 mm	24 V
10 pcs	310-040-015C	50 – 150°C	52 mm	24 V
<b>PYROMETER</b>				
single	397-015-003C	0 – 900°C	52 mm	
<b>EXTERNAL TEMPERATURE INDICATOR</b>				
single	397-035-001G	- 25°C to + 40°C	52 mm	12 V



## Electric Pressure Gauges

- For the indication of engine oil, transmission oil and brake pressure.

Packing	Order number	Scale	Ø Installation	Voltage
<b>ENGINE OIL PRESSURE WITH ISO SYMBOL</b>				
single	350-030-003G	0 - 5 bar	52 mm	12 V
10 pcs	350-030-003C	0 - 5 bar	52 mm	12 V
single	350-030-004G	0 - 10 bar	52 mm	12 V
10 pcs	350-030-004C	0 - 10 bar	52 mm	12 V
single	350-040-003G	0 - 5 bar	52 mm	24 V
10 pcs	350-040-003C	0 - 5 bar	52 mm	24 V
single	350-040-004G	0 - 10 bar	52 mm	24 V
10 pcs	350-040-004C	0 - 10 bar	52 mm	24 V
<b>TRANSMISSION OIL PRESSURE WITH ISO SYMBOL</b>				
single	350-030-005G	0 - 25 bar	52 mm	12 V
single	350-040-005G	0 - 25 bar	52 mm	24 V
10 pcs	350-040-005C	0 - 25 bar	52 mm	24 V
<b>BRAKE PRESSURE WITH ISO SYMBOL</b>				
single	350-040-011G	0 - 10 bar	52 mm	24 V

## Mechanical Pressure Gauges

Voltage supply not needed

- Sensor thread M12x1,5.
- Supplied without illumination (ordered separately).

Packing	Order number	Scale	Ø Installation	Voltage
<b>MECHANICAL PRESSURE GAUGES</b>				
single	150-035-001G	-1 - 1,5 bar	52 mm	n.a.
single	150-035-004G	0 - 7 bar	52 mm	n.a.
single	150-035-006G	0 - 10 bar	52 mm	n.a.
single	150-035-009G	0 - 30 bar	52 mm	n.a.
single	150-035-020G	0 - 10 x100kPa	52 mm	n.a.

## Level Gauges

2 version available (for tubular sensors and lever-arm sensors)

Packing	Order number	Scale	Ø Installation	Voltage	Applicable sensors
<b>FUEL LEVEL GAUGES FOR LEVER-ARM SENSORS</b>					
10 pcs	301-030-001C	0 - 1/1	52 mm	12 V	Plastic lever-arm (221-824-051-4-xxx), ALAS1 3-180 ohm
single	301-030-001G	0 - 1/1	52 mm	12 V	
10 pcs	301-040-001C	0 - 1/1	52 mm	24 V	
single	301-040-001G	0 - 1/1	52 mm	24 V	
<b>FUEL LEVEL GAUGES FOR TUBULAR SENSORS</b>					
10 pcs	301-030-002C	0 - 1/1	52 mm	12 V	Tubular sender flange 54mm (224-011-xxx-xxx) 60/90 - 0 ohm
single	301-030-002G	0 - 1/1	52 mm	12 V	
10 pcs	301-040-002C	0 - 1/1	52 mm	24 V	
single	301-040-002G	0 - 1/1	52 mm	24 V	

## Hourcounters

- Counting up to 99999.9 h.
- Voltage supply: 12 V or 24 V.
- supplied with brackets for stud bolts

Packing	Order number	Version	Ø Installation	Voltage
<b>ELECTRONIC HOURCOUNTERS</b>				
single	331-810-012-001G	No illumination	52 mm	12 V
10 pcs	331-810-012-001B	No illumination	52 mm	12 V
single	331-810-012-007G	Illumination possibility (white)	52 mm	24 V
20 pcs	331-810-012-007B	Illumination possibility (white)	52 mm	24 V
single	331-810-012-002G	Minutes hand (wt)/no illuminat.	52 mm	12 V
20 pcs	331-810-012-002B	Minutes hand (wt)/no illuminat.	52 mm	12 V

## Clocks

- supplied with brackets for stud bolts

Packing	Order number	Scale	Ø Installation	Voltage
<b>CLOCKS</b>				
single	370-214-031-001G	-		12 V
single	370-214-031-003G	-		24 V

## Voltmeters

Packing	Order number	Scale	Ø Installation	Voltage
<b>VOLTMETERS</b>				
single	332-030-001G	8 - 16 V	52 mm	12 V
10 pcs	332-030-001C	8 - 16 V	52 mm	12 V
single	332-040-001G	18 - 32 V	52 mm	12 V
10 pcs	332-040-001C	18 - 32 V	52 mm	12 V

## Ammeters

They operates independently from the vehicle Voltage supply

- Not backlighted

Packing	Order number	Scale	Ø Installation	Voltage
<b>AMMETERS</b>				
single	190-037-002G	60 - 0 - 60 A	52 mm	
10 pcs	190-037-002C	60 - 0 - 60 A	52 mm	
single	190-037-003G	100 - 0 - 100 A	52 mm	
10 pcs	190-037-003C	100 - 0 - 100 A	52 mm	

## Accessories and Spare Parts

Order number	Description
800-005-001G	Munting Brackets for instruments dia. 80mm / 100mm and for tachometers, ammeters (150A), pyrometers and outside temperature gauges dia. 52mm
800-005-015G	Clamp Ring dia. 52mm
800-005-005G	Clamp Ring dia. 80mm
800-005-007G	Clamp Ring dia. 100mm
800-005-002G	2 x Lamp holder with light bulb 12V 2W
800-005-003G	2 x Lamp holder with light bulb 24V 2W
800-005-019G	1 x Lamp holder with light bulb 12V 1,2W
999-115-015	Three way socket for tab terminal for Pressure gauges, Temperature gauges, Fuel level gauges and Voltmeters (100pcs)
999-115-150	Female connector housing, two way, for lamp holder with thick light bulb (100pcs)
999-115-016	Female connector housing, eight way, for speedometers and tachometers dia. 80mm and 100mm (100pcs)
2910002025200	Make Point Switch



## 1.2 Analog Instrument Clusters



### 1.2.1 Centrobases 500

## 1.2.1 Centrobases 500

The Centrobases 500 instrument cluster displays all the data related to the engine (analog and digital) on a central display, thus allowing greater convenience and improved ergonomics in the cockpit. Centrobases 500 is continuously adapted and updated to meet customer needs.

The dials can be customized according to the needs in terms of scales, warning and alarm telltales and graphic design.

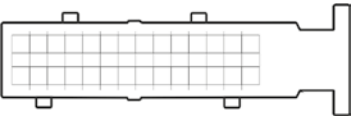
Our Centrobases 500 instrument stands out for its efficiency, flexibility, quality, reliability and ease of use.

CENTROBASE 500	
Order number	Description
A2C59212186	 <ul style="list-style-type: none"> <li>• Analogue display of engine rpm, vehicle speed, temperature and fuel level; Voltage battery and pressure available as options.</li> <li>• Digital display: choice of operating hours, total mileage, travel counter, travel hours, time of day and current gear.</li> <li>• The Display includes up to 15 telltales</li> <li>• Autotest for 5 telltales</li> <li>• Programmable from diagnostic interface (K-line).</li> </ul>
ACCESSORIES FOR THE WIRING	
Order number	Description
2910000243500	 <p>Connector</p>
2910000243600	 <p>Contacts housing</p>
A2C53117261	 <p>Contacts</p>



## 1.3 CAN Instrument Cluster

### 1.3.1 Flex Cluster



### 1.3.1 Flex Cluster

Countless tasks. One solution

Our components always meet the highest standards in terms of quality, durability and design, but the FlexCluster tool offers even more: maximum functionality from every point of view.

**Maximum flexibility:** The proven Gateway functionality allows data to be processed by two different CAN buses running different protocols (for example, SAE J1939 and / or CAN Open). This allows flexibility in use and ensures that all important data and information can be transmitted to other control units.

Additional peripheral instruments, for example the oil pressure gauge or fuel level indicator or operating hours, can be controlled via FlexCluster. As a result, all data necessary for vehicle operation are highlighted.

**Maximum safety:** The FlexCluster indicating instrument offers a large number of customizable options: the management of DTCs (Diagnostic Trouble Code) in accordance with the SAE J1939 protocol is made extremely simple. A backup battery back-up system ensures that the clock does not reset in the event of a power loss.

**Maximum compatibility:** Maximum compatibility is guaranteed thanks to a high quantity of inputs and outputs combined with multiple CAN inputs.

**Massima individuality:** The layout of the central dot-matrix display is completely customizable and can also be programmed to show company icons and logos. All signal lights can be individually selected in terms of shape and color. Possible also a range of options for dials and frames.

**Maximum ergonomics:** The best possible ergonomics is guaranteed with a space saving design. Not only does it allow optimal readability of the instruments, it also helps to improve comfort levels in the cockpit.

**Maximum adaptability:** Thanks to specific software, the FlexCluster tool can be programmed and configured to precisely meet any customer need.

**Maximum robustness:** The high degree of protection (IP 67) of the housing indicates that FlexCluster is suitable for continuous use in the most extreme environmental conditions (heat, cold, humidity, vibrations, etc.)

Technical specification:	
Dimension (mm):	290.6 x 143.5 x 72.5
Nominal Voltage:	12 V or 24 V
Operating Voltage:	from 9 V to 16 V or from 18 V to 32 V
Operating Temperature:	from -40°C to + 75°C
Protection class:	IP 67 Front and rear
Characteristics:	
Appearance:	Black background with red pointers, multicolour print of the dial, personalization of indicators, indicator lights, indicator frames and HMI interface
Illumination:	white backlight and AMBER color display lighting, adjustable intensity via PWM signal
Gauges:	4 in total (2 large and 2 small) such as Tachometer, Tachometer, Fuel Level, Coolant Temperature or Engine Oil Pressure
Display:	Dot matrix LCD, technology: FSTN Resolution: 115 x 145 Active area: 65.23 x 51.73 mm
Telltals:	24 + 2 (located close to the small gauges)
Wake-Up:	CAN or ignition terminal (+15)
EOL programming:	KWP2000 on CAN
Analogue Inputs (resistive/Voltage):	6 (2 they can be used as Voltage inputs)
Digital Inputs:	24
Frequency Inputs:	4
Current Inputs:	1
Outputs:	3 x 500 mA They can also be used as frequency or digital outputs (Low side)
External buzzer output:	1
D+ alternator load	1 (150 Ω pull up @ 24 V or 53 Ω pull up @ 12 V)
Interfaces:	2 x CAN, 1 x LIN 1 x for additional satellite indicators
Connectors:	2 x Tyco Super Seal (35 pin e 23 pin) moulded with the back of the instrument cluster

This solution offers significant design flexibility in order to realize the vehicle information control functionality and the end customer's needs, including improvement or modification of the functionalities during the vehicle's life. With a special application programming software, we offer our customers a powerful and consolidated indicating instrument.

The FlexCluster indicating instrument has been specifically developed to withstand the harsh conditions in which special vehicles operate.

With four optimally positioned instruments, 26 configurable lights and a large dot matrix display, the FlexCluster instrument cluster is one of the most advanced

system components available today for special vehicles.

Extensive customization options enable the system to meet even the most stringent requirements while providing an optimal combination of performance and value for money.





## 2. Sensors and Switches

### 2.1 Speed and RPM Sensors

2.1.1 Blocking oscillator Sensors

2.1.2 Inductive Sensors

2.1.3 Hall effect Sensors

2.1.4 Generator Sensors

2.1.5 Active wheel speed Sensors



## 2.1.1 Blocking Oscillator Sensors

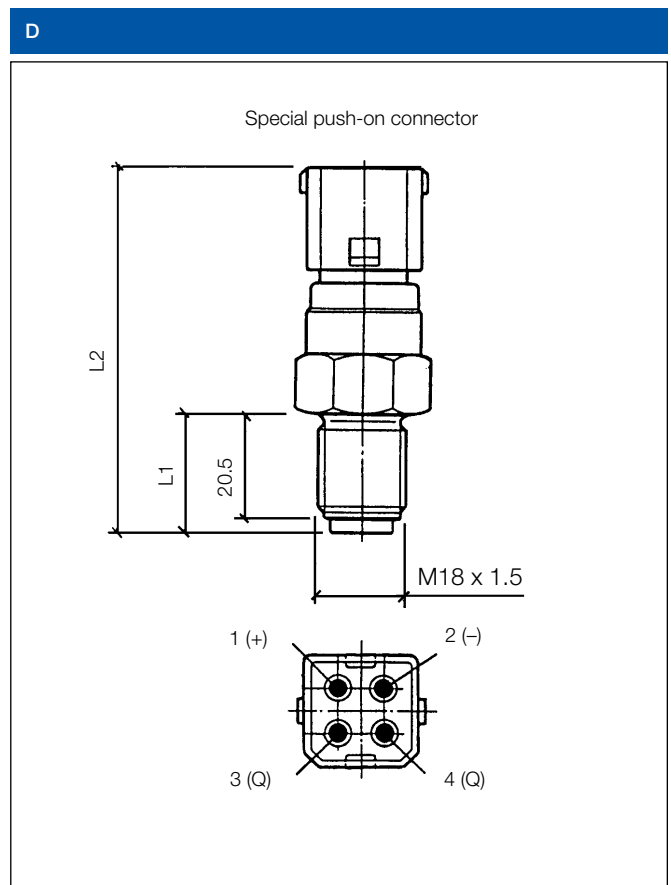
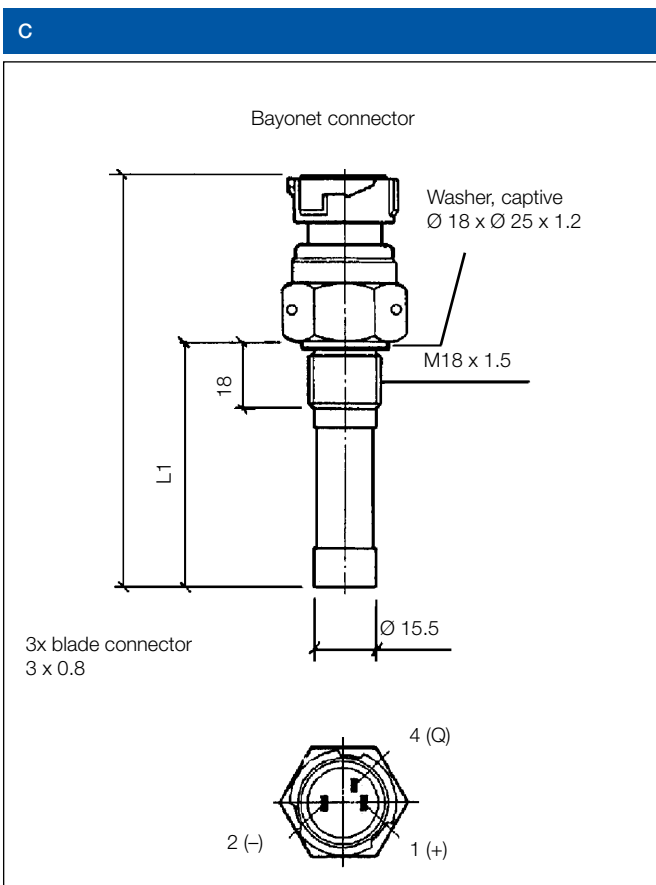
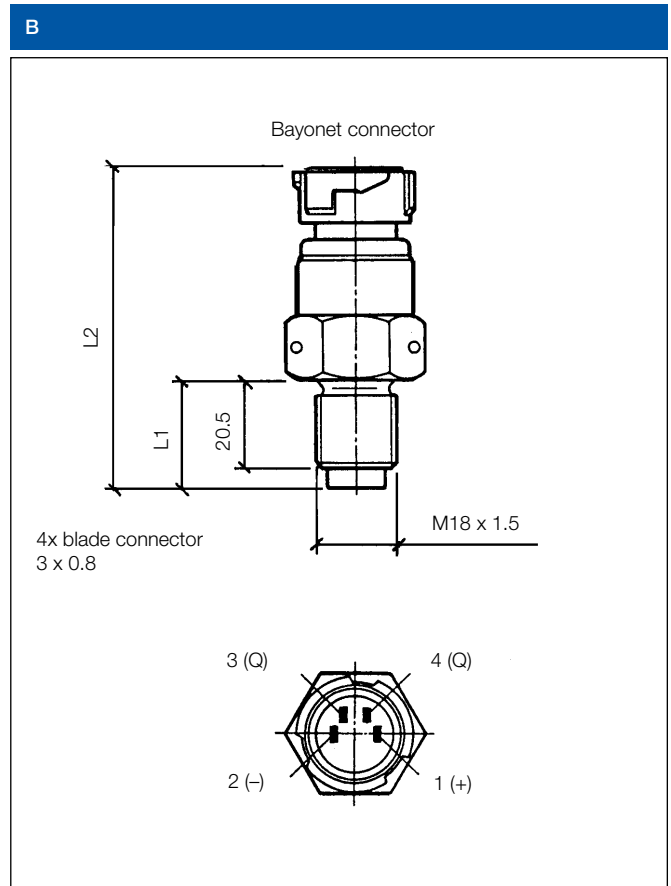
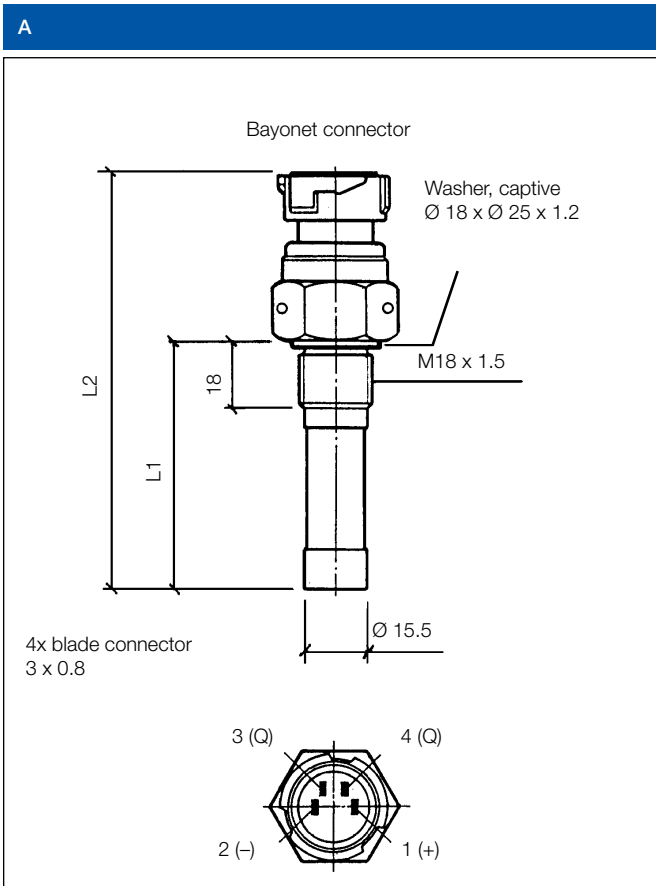

Order Part No.	Design	Lenght [mm]	
		L1	L2
340-216-010-003C	D	25	78.3
340-216-005-002C	A	63.2	106
A2C59513983	B	25	74
340-216-005-001C	A	90.2	133

Technical characteristics	
Electrical connection	4-pole, insulated return
POWER SUPPLY	
Voltage	8–15 V
Current	12 mA
Operating temperature	-40 °C a +130 °C
Max. frequency	400 Hz
Distance sensor - pulse wheel	from 0.3 a 1.4 mm

Order Part No.	Design	Lenght [mm]	
		L1	L2
340-216-010-004C	C	90.2	133

Technical characteristics	
Electrical connection	4-pole, insulated return
POWER SUPPLY	
Voltage	30 V
Current	14 mA
Operating temperature	from -40 °C to +130 °C
Max. frequency	400 Hz
Distance sensor - pulse wheel	from 0.3 to 1.4 mm

## 2.1.2 Inductive Sensors

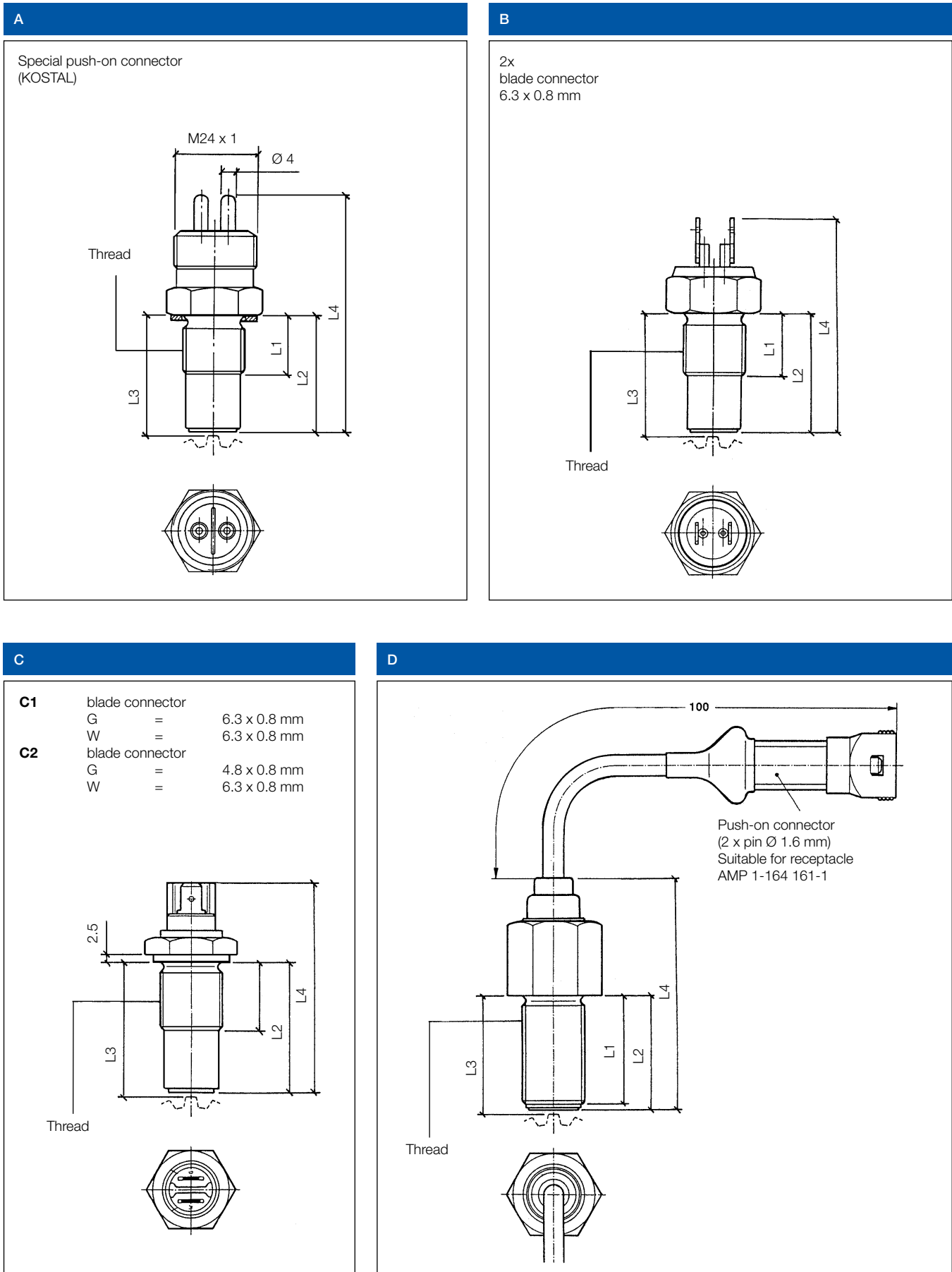

Order Part No.	Thread	Length[mm]				Design	min. [°C]	RI [Ω]
		L1	L2	L3	L4			
340-804-005-007C	M18 x 1.5	15	35	36.1 ±0.1	71.5	A	-25	1050
340-804-005-001C	M18 x 1.5	18	35	36.15–35.80	71.5	A	-30	1050
340-804-005-013A	M18 x 1.5 <sup>1</sup>	18	71.4	72.63–72.20	107.9	A	-30	1050
340-804-005-015C	M18 x 1.5	18	99.1	101.15–100.55	135.6	A	-30	1050
340-804-005-018C	M18 x 1.5 <sup>1</sup>	18	45.7	46.95–46.45	82.2	A	-30	1050
340-804-005-020C*	M18 x 1.5 <sup>1</sup>	18	37.3	38.45–38.1	73.8	A	-30	1050
340-804-006-002C	M18 x 1.5	18	35	36.1 ±0.1	63.5	B	-30	1050
340-804-007-019C	M18 x 1.5 <sup>8,9</sup>	18.2	70.7	71.8 ±0.1	79.7	C2	-25	1050
340-804-030-006B	M18 x 1.5	18.2	70.7	71.8 ±0.1	93.5	D	-25	1050
340-804-007-020C	M18 x 1.5 <sup>8,9</sup>	20	39	40.1 ±0.1	62	C2	-25	1050
340-804-030-005B	M18 x 1.5	23.3	25	26.1 ±0.1	67	D	-25	1050
340-804-005-002C	M18 x 1.5	24.9	26.5	27.65–27.30	63	A	-30	1050
340-804-005-028C	M18 x 1.5	24.9	63.4	64.55–64.20	99.9	A	-30	1050
340-804-005-033C	M18 x 1.5	24.9	26.5	27.5	63	A	-30	1050
340-804-007-002A	M18 x 1.5	27.5	28.5	29.6 ±0.1	70	C1	-25	1050
340-804-007-004C	3/4" - 16 UNF-2A <sup>8</sup>	27.5	28.5	29.6 ±0.1	70	C1	-25	1050
340-804-007-013C	M18 x 1.5 <sup>8</sup>	27.5	28.5	29.6 ±0.1 <sup>+0.15</sup> <sub>-0.2</sub>	70	C1	-25	1050
340-804-006-007C	M18 x 1.5	33	34	35.1 ±0.1	62	B	-30	1050
340-804-007-001C	M18 x 1.5 <sup>9</sup>	33	34	35.1 ±0.1	70	C1	-25	1050
340-804-007-003C	M18 x 1.5	33	34	35.1 ±0.1	64.5	B	-25	1050
340-804-007-011C/G	M18 x 1.5	33	34	35.1 ±0.1	70	C1	-25	1050
340-804-006-003Z	M18 x 1.5	17	25	26.1 ±0.1	56.2	B	-30	1050

1 With sealing washer, captive

8 With collar

9 With hexagonal nut M18 x 1.5

\*Supplied on request - limited availability

Technical characteristics	
Electrical connection	2-pole, Insulated return
<b>VOLTAGE INDEPENDENT</b>	
Operating temperature	from -25 °C a +140 °C
Resistenza interna, Ri	1050 Ω ±100 Ω
<b>TEST CONDITIONS</b>	
Gear	36 denti
Diametral pitch	2.75
Rotational speed	416.6 min <sup>-1</sup>
Frequency	250 Hz
Tooth width	7.5 mm
Load	47 kΩ

## 2.1.3 Hall effect Sensors

### Dimensions [mm]

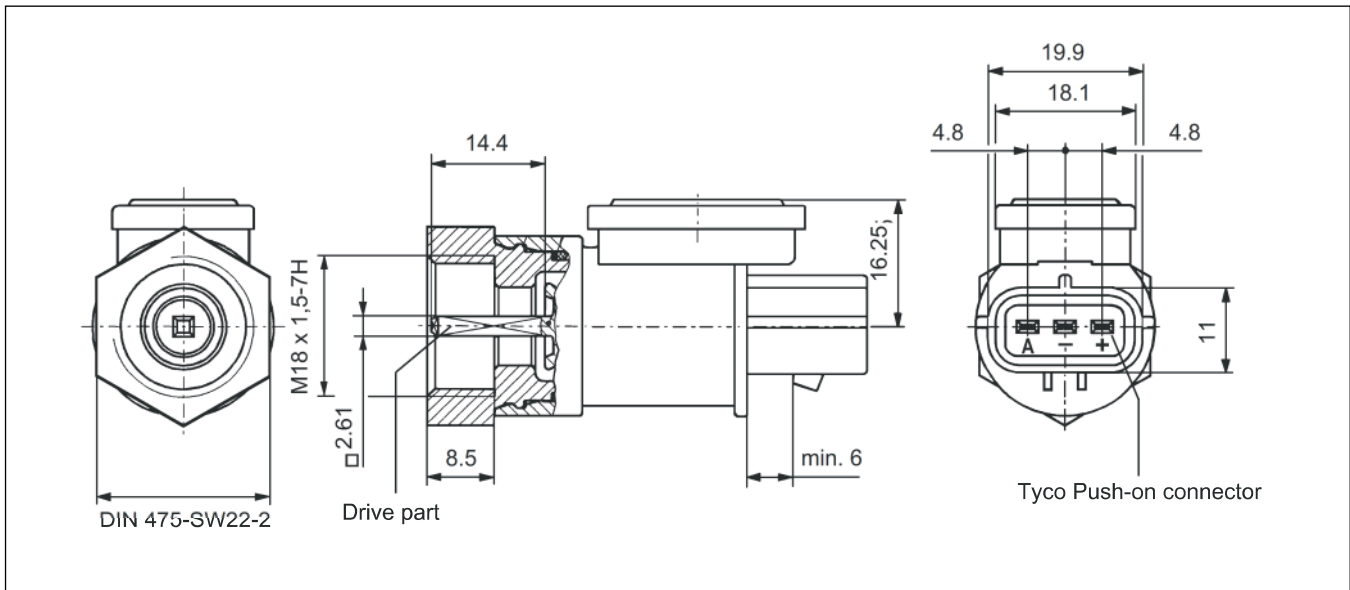

#### Technical characteristics

Electrical connection	3-pole, Insulated return
Power supply	from 10.8V to 16V
Operating temperature	from -30°C to +150°C
Storage temperature	from -40°C to +150°C
Rotational speed	4500 min <sup>-1</sup> max
Number of pulses per revolution	4

Order Part No.: 340-214-013-001Z

## 2.1.4 Generator Sensors

### Dimensions [mm]

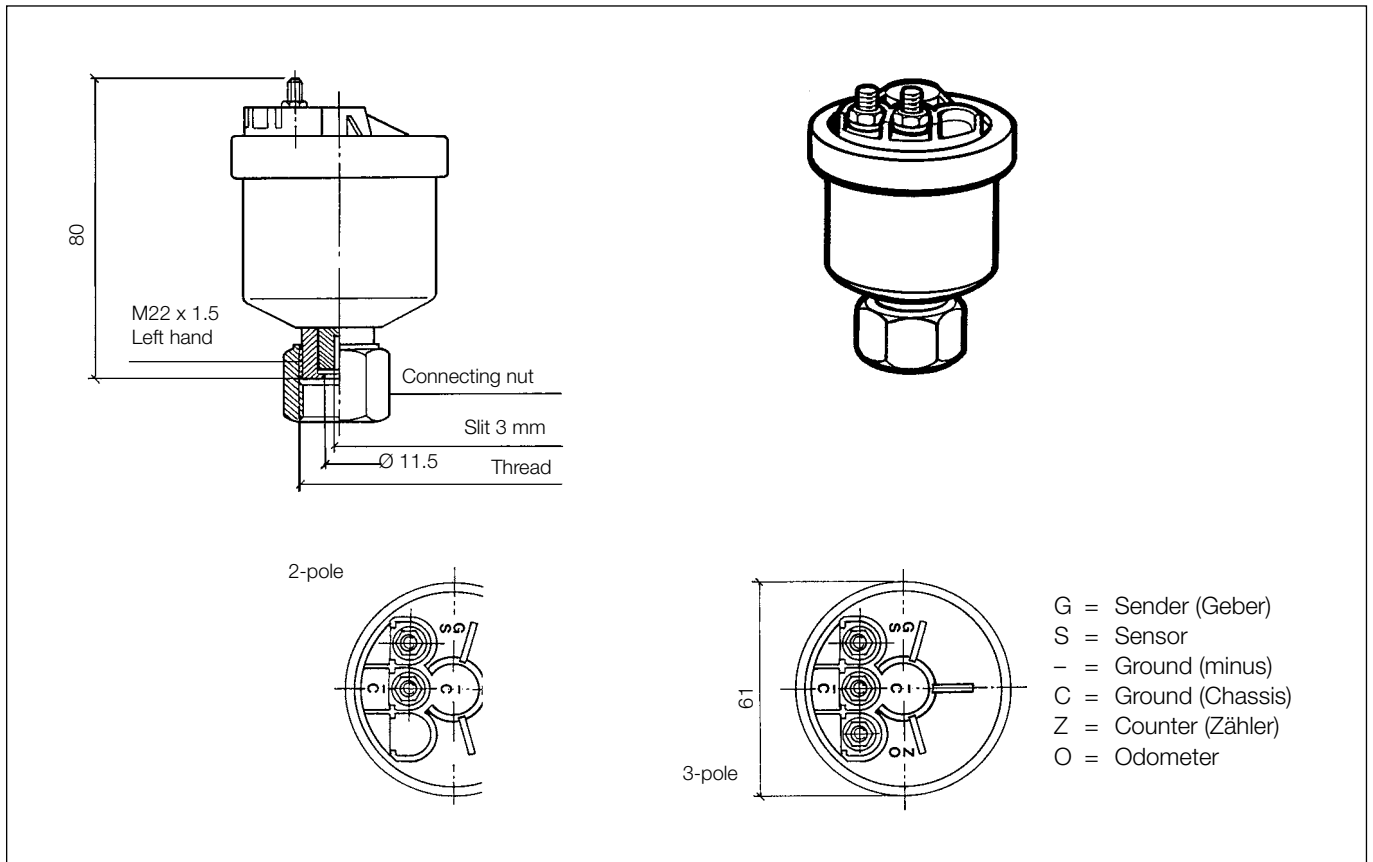

### Types of connection

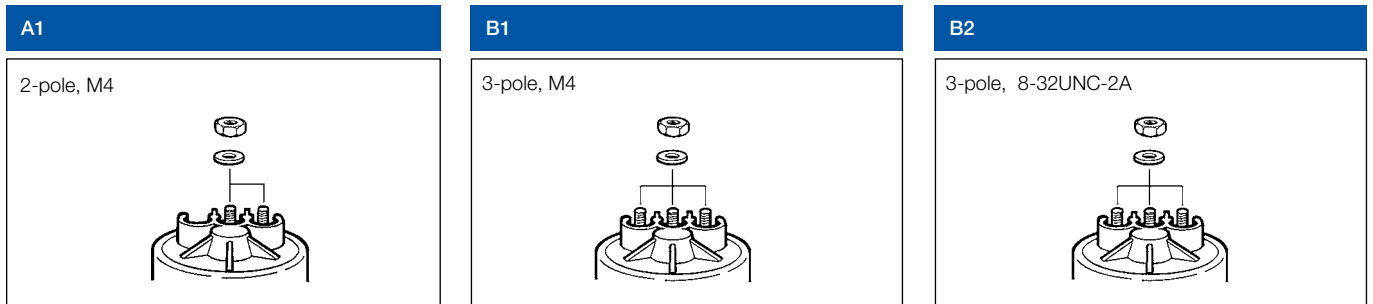

Order Part No.	Thread	Types of connection
340-808-001-002C	M22 x 1.5	A1
340-807-001-001C	M22 x 1.5	B1
340-808-001-004G	7/8" - 18NS-2A	A1
340-807-001-003C	7/8" - 18UNS-2B	B2

Technical characteristics	
Electrical connection	2-pole, 3-pole, Insulated return
Rotational speed	Max. 3,000 min <sup>-1</sup>
No-load voltage	19.3 V at 2,000 min <sup>-1</sup>
Operating temperature	from -25 °C a +90 °C
Protection class	IP54 as per DIN 40050

## 2.1.5 Active wheel speed Sensor

### Dimensions [mm]

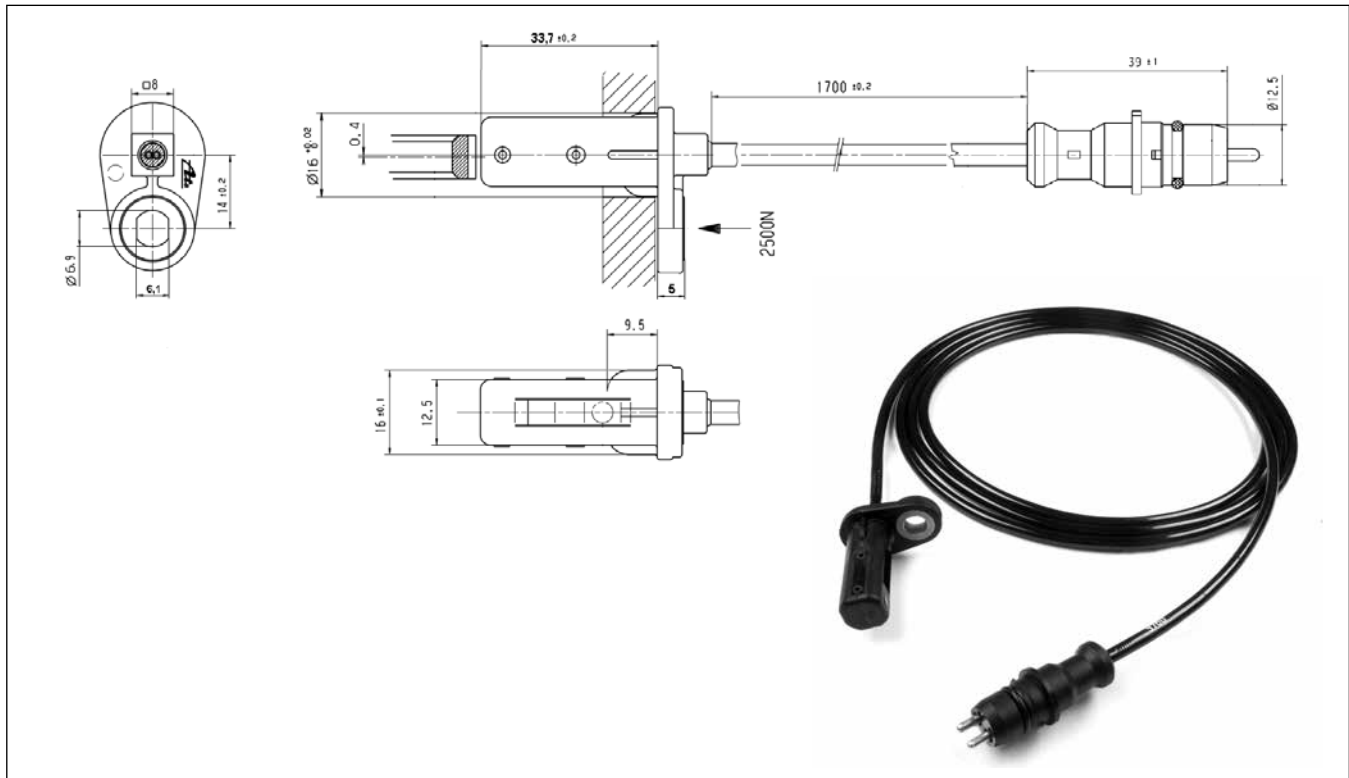

Order Part No. **10.0711-6146.3**

#### Technical characteristics

Voltage	-40 °C a +60 °C: 7,5 V–20 V +60 °C a+150 °C: 7,5 V–16 V
Operating temperature	Sensor body: 40 °C to +150 °C Cable/Plug: -40 °C to +115 °C
Plug Swoboda	IP 67 according to DIN 40050 part 9
Current	$I_{low}$ : 7 mA (+20%/-16%) $I_{high}$ : 14 mA (+20%/-16%)
Cable Length	1.700 mm (other lengths available on request)

#### Description

This active sensor, derived from mass production, has characteristics of high reliability and robustness. Thanks to its Dimensions can be installed on a large variety of vehicles.

- Pulse generator for pulse wheel.
- Cable with “Swoboda” type plug termination.
- Type of fixing like shown in the picture



## 2.2 Pressure Sensors

2.2.1 Pressure sensors, Single-Pole, common ground

2.2.2 Pressure Sensors with Warning Contact, common ground

2.2.3 Pressure Sensors, Insulated Return

2.2.4 Pressure Sensors with Warning Contact, 3 Connection



## 2.2.1 Pressure sensors, Single-Pole, common ground

### Circuit diagram

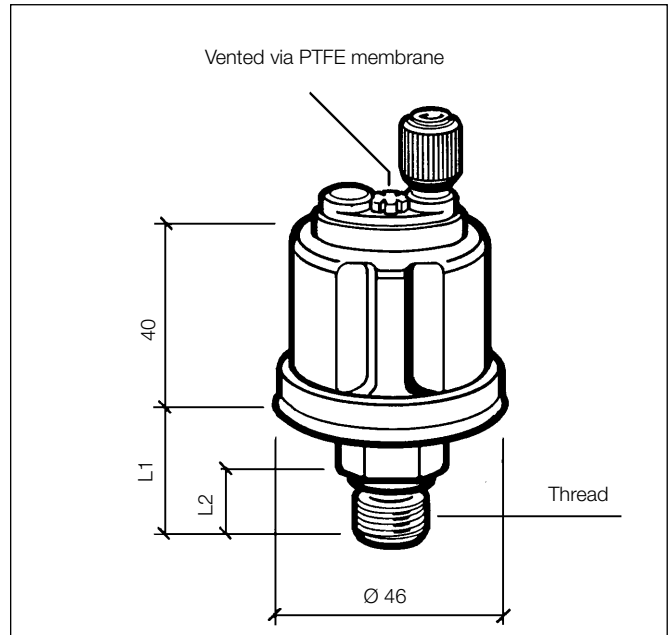
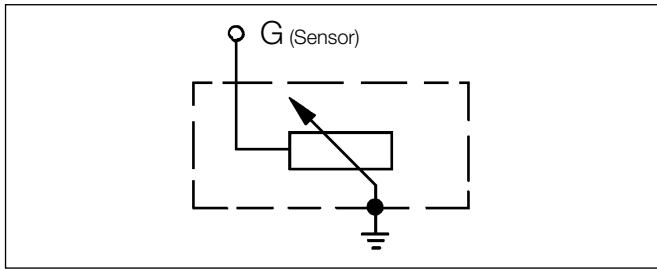

### Types of connection

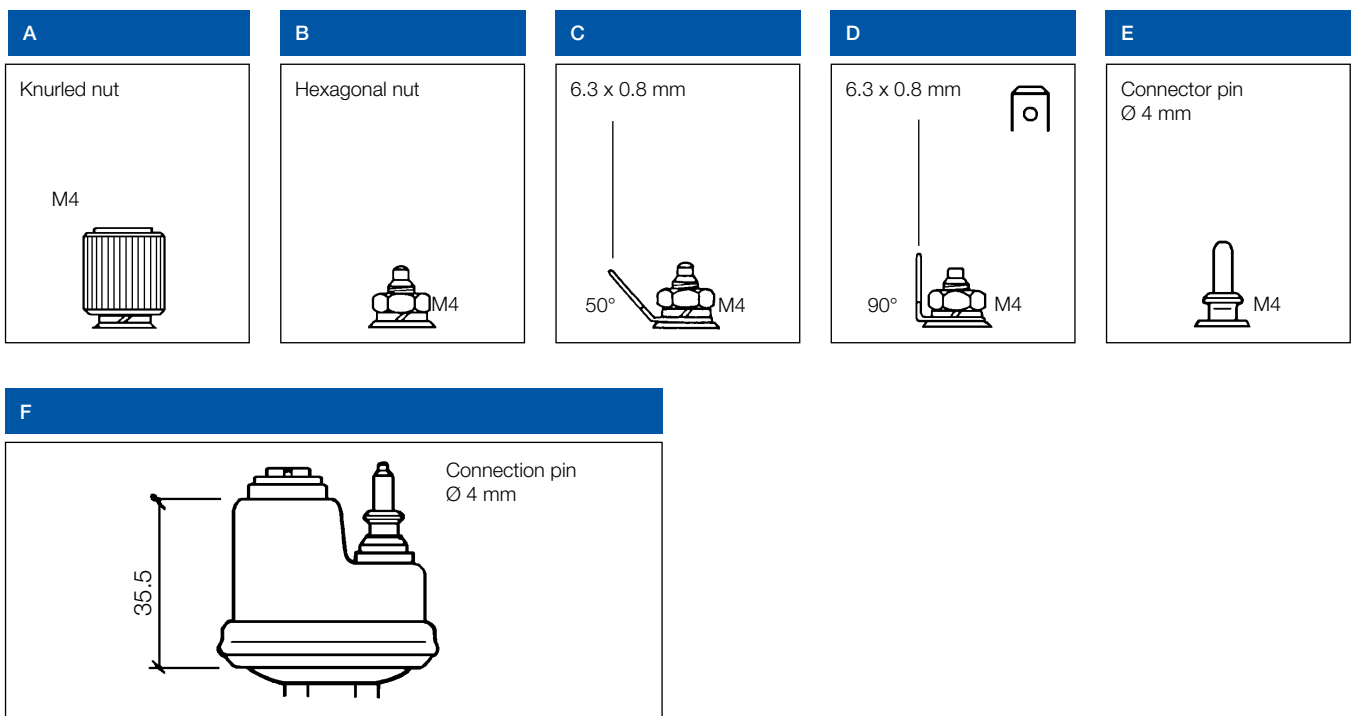

Order Part No.	Measuring range	Thread	Dimensions		Type of connection	bar
	[bar]		L1 [mm]	L2 [mm]		[ max. 2 sec.]
360-081-029-087C	3	M12 x 1.5	20.5	12	E	30
360-081-052-003C	3	M12 x 1.5	20.5	12	F	30
360-081-029-001C/K	5	M10 x 1 tapered, short	19.5	11	A	30
360-081-029-004C	5	1/8" - 27 NPTF	19.5	11	A	30
360-081-029-008C	5	1/4" - 18 NPTF	23.8	15.3	A	30
360-081-029-025C	5	M18 x 1.5 1	20.5	12	A	30
360-081-029-026C	5	M14 x 1.5	20.5	12	A	30
360-081-029-041C	5	1/8" - 27 NPTF	19.5	11	D	30
360-081-029-059C	5	M18 x 1.5 1	20.5	12	B	30
360-081-029-065C	5	M14 x 1.5	25.5	12	B	30
360-081-029-085C	5	M12 x 1.5	20.5	12	A	30
360-081-029-099C**	5	M12 x 1.25	19.5	10	A	30
360-081-029-010C/K	10	M10 x 1 tapered, short	19.5	11	A	30
360-081-029-012C/K	10	1/8" - 27 NPTF	19.5	11	A	30
360-081-029-013C/K	10	M12 x 1.5	20.5	12	A	30
360-081-029-020C	10	1/4" - 18 NPTF	23.8	15.3	A	30
360-081-029-033C	10	M14 x 1.5	20.5	12	A	30
360-081-029-038C	10	M14 x 1.5	20.5	12	C	30
360-081-029-042C	10	1/8" - 27 NPTF	19.5	11	C	30
360-081-029-062C	10	R 1/8 DIN 2999	19.5	11	C	30
360-081-037-006C	16	M14 x 1.5	20.5	12	B2	40
360-081-037-007C	16	1/8" - 27 NPTF3	20.5	12	D	40
360-081-037-019C	16	M12 x 1.5	20.5	12	B	40
360-081-037-003C	25	M18 x 1.5	20.8	12	D	50
360-081-037-008C	25	M10 x 1 tapered, short	19.5	11	C	50
360-081-037-010C	25	1/8" - 27 NPTF	19.5	11	D	50
360-081-037-011C	25	M10 x 1 tapered, short	19.5	11	C	50
360-081-037-013C	25	M14 x 1.5	20.5	12	D	50
360-081-037-017C	25	M14 x 1.5	20.5	12	D	50
360-081-037-018C	25	M18 x 1.5	20.5	12	D	50

\*\* On request – limited availability

Technical characteristics	
Voltage	6–24 V
Operating temperature	from -25 °C to +100 °C
Resistive range	from 10 Ω to 184 Ω

## 2.2.2 Pressure Sensors with Warning Contact, common ground

### Circuit diagram

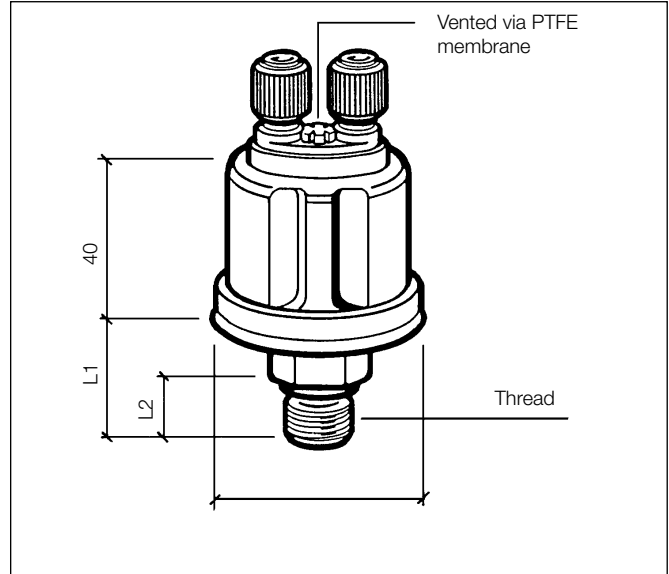
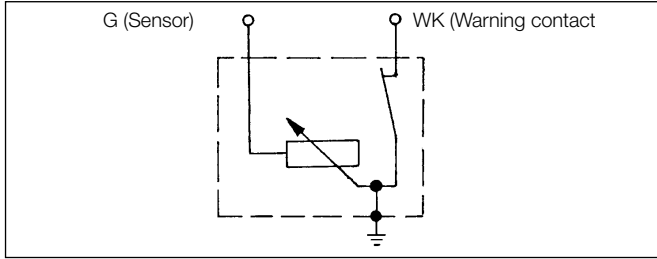

### Types of connection

<p><b>A</b></p> <p>(2x) Knurled nut, M4</p> <p>M4</p>	<p><b>B</b></p> <p>(2x) 6.3 x 0.8 mm (50°)</p> <p>M4</p>	<p><b>C</b></p> <p>WK 6.3 x 0.8 mm (50°) G 4.8 x 0.8 mm (50°)</p> <p>M4</p>	<p><b>D</b></p> <p>WK 4.8 x 0.8 mm (50°) G 6.3 x 0.8 mm (50°)</p> <p>M4</p>
<p><b>E</b></p> <p>(2x) Hexagonal nut, M4</p> <p>M4</p>	<p><b>F</b></p> <p>WK 6.3 x 0.8 mm (90°) G M4</p> <p>M4</p>	<p><b>G</b></p> <p>G 6.3 x 0.8 mm (50°)</p> <p>M4</p>	<p><b>H</b></p> <p>(2x) 6.3 x 0.8 mm</p> <p>M4</p>
<p><b>J</b></p> <p>WK 4.8 x 0.8 mm (90°) G 6.3 x 0.8 mm (90°)</p> <p>M4</p>	<p><b>K</b></p> <p>WK 6.3 x 0.8 mm (90°) G 4.8 x 0.8 mm (90°)</p> <p>M4</p>	<p><b>L</b></p> <p>Hexagonal nut, M5</p> <p>M5</p>	

## Types of connection

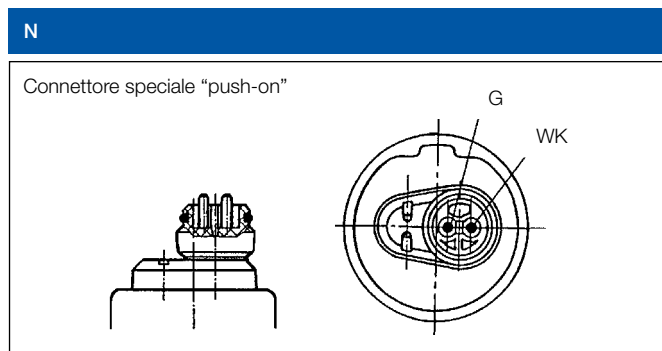
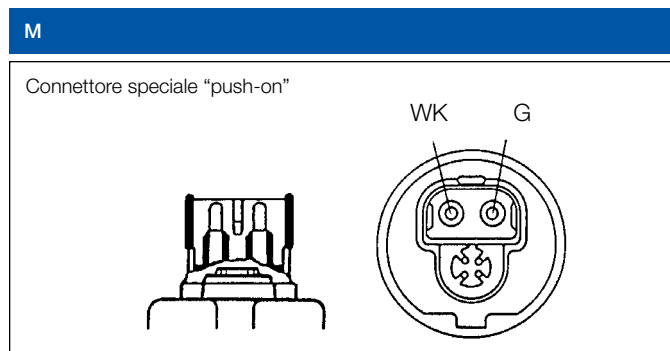

Order Part No.	Measuring range	Thread	Warning contact	Dimensions		Type	bar [max. 2 sec.]
	[bar]		[bar]	L1 [mm]	L2 [mm]		
360-081-030-001C/K	5	M10 x 1 tapered, short	0.25 ±0.15	19.5	11	A	30
360-081-030-002C/K	5	M10 x 1 tapered, short	0.5 ±0.15	19.5	11	A	30
360-081-030-004C	5	M10 x 1 tapered, short	0.7 ±0.15	19.5	11	A	30
360-081-030-008C	5	M12 x 1.5	0.5 ±0.15	20.5	12	A	30
360-081-030-010C	5	1/8" - 27 NPTF	1.4 ±0.3	19.5	11	A	30
360-081-030-014C	5	M10 x 1 tapered, short	0.6 ±0.15	19.5	11	A	30
360-081-030-018C	5	M10 x 1 tapered, short	1.2 ±0.15	19.5	11	A	30
360-081-030-025C	5	M18 x 1.5 1	0.4 ±0.2	20.5	12	B	30
360-081-030-028C/K	5	M14 x 1.5	0.5 ±0.15	20.5	12	A	30
360-081-030-033C	5	M14 x 1.5 1	0.4 ±0.1	20.5	12	F	30
360-081-030-036C/K	5	M18 x 1.5 1	0.5 ±0.15	20.5	12	A	30
360-081-030-049C	5	1/8" - 27 NPTF	0.4 ±0.1	19.5	11	A	30
360-081-030-053C	5	M18 x 1.5 4	0.25 ±0.15	20.5	12	B	30
360-081-030-065K	5	R 1/8 DIN 2999	0.4 ±0.15	19.5	11	B	30
360-081-030-071C	5	M14 x 1.5 1	0.4 ±0.15	20.5	12	F	30
360-081-030-085C	5	M18 x 1.5 1	0.4 <sup>+0.2</sup> <sub>0.1</sub>	20.5	12	C	30
360-081-030-086C	5	1/8" - 27 NPTF	0.5	19.5	11	C	30
360-081-030-097C	5	M14 x 1.5	0.5 ±0.15	20.5	12	B	30
360-081-030-119C	5	1/8" - 27 NPTF	1.4 ±0.3	19.5	11	H	30
360-081-030-157C	5	M18 x 1.5 1	0.5 <sup>+0.15</sup>	20.5	12	F	30
360-081-034-002C	5	M14 x 1.5	0.25 ±0.15	20.5	12	L	30
360-081-034-004C	5	M18 x 1.5	0.25 ±0.15	20.5	12	L	30
360-081-062-002A	5	M14 x 1.5 1	0.4 <sup>+0.2</sup>	20.5	12	N	30
360-081-062-004A	5	M14 x 1.5 1	1.0 <sup>+0.2</sup>	20.5	12	N	30
360-081-030-154C*	7	1/8" - 27 NPTF	0.7 ±0.15	19.5	10	L	30
360-081-030-009C/K	10	M10 x 1 tapered, short	0.5 ±0.15	19.5	11	A	30
360-081-030-015C	10	1/8" - 27 NPTF	0.8 ±0.3	19.5	12	A	30
360-081-030-017C	10	M10 x 1 tapered, short	0.9 ±0.15	19.5	11	A	30
360-081-030-019C	10	M12 x 1.5	1.5 ±0.15	20.5	12	A	30
360-081-030-022C	10	M12 x 1.5	0.5 ±0.15	20.5	12	A	30
360-081-030-030C	10	M14 x 1.5	0.7 ±0.15	20.5	12	A	30
360-081-030-031C	10	M10 x 1 tapered, short	0.5 ±0.15	19.5	11	B	30
360-081-030-032C/K	10	M14 x 1.5	0.5 ±0.15	20.5	12	A	30
360-081-030-037C	10	M18 x 1.5 1	0.75 ±0.15	20.5	12	A	30
360-081-030-039C	10	M10 x 1 tapered, short	0.75 ±0.15	19.5	11	B	30

Order Part No.	Measuring range	Thread	Warning contact	Dimensions		Type	bar
	[bar]		[bar]	L1 [mm]	L2 [mm]		[ max. 2 sec.]
360-081-030-041C	10	M10 x 1 tapered, short	2.0 ±0.3	19.5	11	A	30
360-081-030-052C	10	1/8" - 27 NPTF	0.5	19.5	11	A	30
360-081-030-063C	10	M14 x 1.5	1.0 ±0.15	20.5	12	B	30
360-081-030-070C	10	M18 x 1.5 <sup>1</sup>	0.5 ±0.15	20.5	12	B	30
360-081-030-074C	10	M18 x 1.5 <sup>1</sup>	0.5 ±0.15	20.5	12	A	30
360-081-030-075C	10	M14 x 1.5	5.0 ±0.3	20.5	12	H	30
360-081-030-078C	10	M14 x 1.5	1.0 ±0.15	20.5	12	E <sup>2</sup>	30
360-081-030-100C	10	1/8" - 27 NPTF	4.0 <sup>+0.5</sup>	19.5	11	B	30
360-081-030-107C	10	M16 x 1.5	5.5 ±0.3	20.5	12	D	30
360-081-030-112C	10	M10 x 1 <sup>1</sup>	1.35 ±0.15	18.5	10	K	30
360-081-030-122C	10	M18 x 1.5 <sup>1</sup>	0.75 ±0.15	20.5	12	D	30
360-081-030-138C	10	1/8" - 27 NPTF	1.25 <sup>+0.3</sup>	19.5	11	J	30
360-081-030-152C	10	M10 x 1 tapered, short	5.2 ±0.5	19.5	11	H	30
360-081-061-002C	10	M14 x 1.5	0.7 ±0.15	20.5	12	M	30
360-081-061-003C	10	M14 x 1.5	1.0 ±0.15	20.5	12	M	30
360-081-061-006C	10	M12 x 1.5 tapered, short	5.0 ±0.3	21.5	13	M	30
360-081-062-003C	10	M14 x 1.5 <sup>1</sup>	5.5 ±0.3	20.5	12	N	30
360-081-062-005A	10	M14 x 1.5	3.0 ±0.3	20.5	12	N	30
360-081-053-001C	25	1/8" - 27 NPTF <sup>3</sup>	15.5 <sup>+1.5</sup> <sub>-0.5</sub>	19.5	11	J	50
360-081-053-003C	25	M18 x 1.5	5.5 <sup>+1.0</sup> <sub>-0.5</sub>	20.5	12	E	50
360-081-053-004C	25	1/8" - 27 NPTF <sup>3</sup>	14.5 <sup>+1.5</sup> <sub>-0.5</sub>	19.5	11	B	50

<sup>1</sup> With sealing washer, captive

<sup>2</sup> without Hexagonal nut M4

<sup>3</sup> with restrictions

<sup>4</sup> with attachment plate

\*supplied on request - limited availability

Order Part No.	Measuring range	Thread	Warning contact	Dimensions		Type	bar
	[PSI]		[PSI]	L1 [mm]	L2 [mm]		[ max. 2 sec.]
360-081-030-020C	80	1/4" - 18 NPTF	8 ±2	23.8	15.3	A	30
360-081-030-023C	80	1/8" - 27 NPTF	6 ±2	19.5	11	A	30

#### Technical characteristics

Voltage	6–24 V
Warning contact	CLOSES with falling pressure
Switching capacity of Warning contact	Max. 5 W non-inductive
Operating temperature	from -25 °C to +100 °C
Resistive range	from 10 Ω to 184 Ω

## 2.2.3 Pressure Sensors, Insulated return

### Circuit diagram

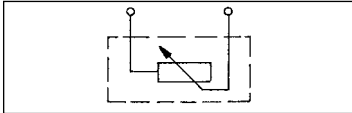

### Types of connection

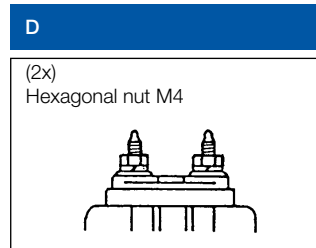
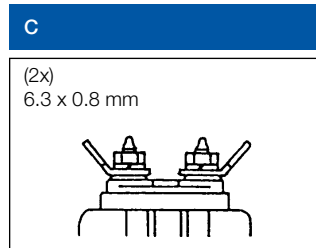
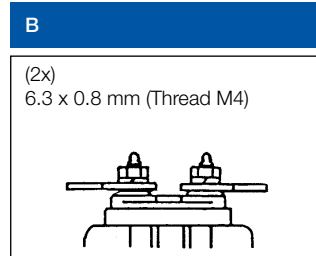
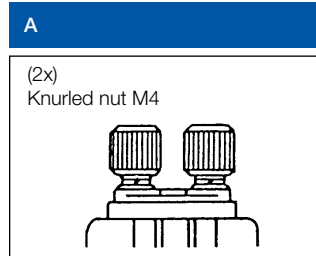

Technical characteristics	
Voltage	6–24 V
Operating temperature	from -25 °C to +100 °C
Resistive range	from 10 Ω to 184 Ω

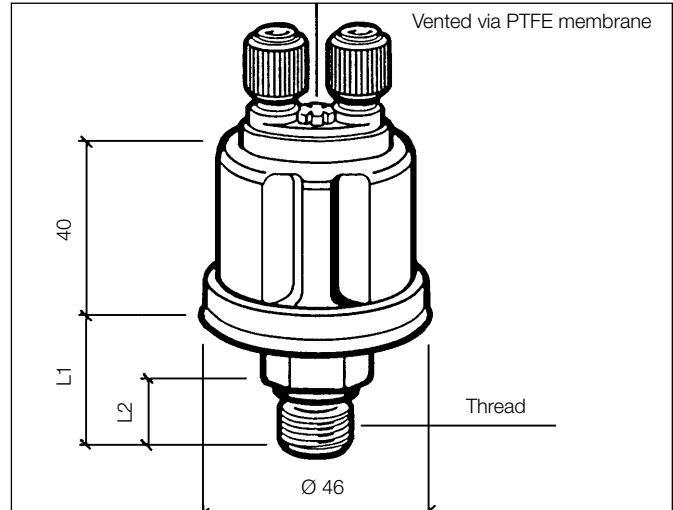

Order Part No.	Measuring range [bar]	Thread	Dimensions		Type of connection	bar [max. 2 sec.]
			L1 [mm]	L2 [mm]		
360-081-032-011C	2	M12 x 1.5	20.5	12	C	30
360-081-032-025C	2	1/8" - 27 NPTF	19.5	11	C	30
360-081-032-058C	2	M18 x 1.5	20.5	12	A	30
360-081-032-001C	5	1/8" - 27 NPTF	19.5	11	A	30
360-081-032-002C	5	M10 x 1 tapered, short	19.5	11	A	30
360-081-032-007C	5	1/8" - 27 NPTF	19.5	11	B	30
360-081-032-013C	5	M18 x 1.5	20.8	12	A	30
360-081-032-016C	5	1/4" - 18 NPTF	23.8	15.3	A	30
360-081-032-059C	5	M18 x 1.5	20.5	12	D1	30
360-081-032-060C	5	M14 x 1.5	20.5	12	D1	30
360-081-032-052C	7	1/8" - 27 NPTF	19.5	11	C	30
360-081-032-003C	10	M10 x 1 tapered, short	19.5	11	A	30
360-081-032-004C	10	M12 x 1.5	20.5	12	A	30
360-081-032-006C	10	M14 x 1.5	20.5	12	A	30
360-081-032-008C	10	M18 x 1.5	20.5	12	A	30
360-081-032-014C	10	1/8" - 27 NPTF	19.5	11	A	30
360-081-032-053C	10	M12 x 1.5	20.5	12	A	30
360-081-032-057C	10	R1/8 DIN 2999	40	10	A	30
360-081-038-014C	16	M14 x 1.5	20.5	12	D1	30
360-081-038-001C	25	M14 x 1.5	20.5	12	D	50
360-081-038-002C	25	3/8" - 18 Dryseal NPTF	23.8	15.3	B	50
360-081-038-003C	25	1/8" - 27 NPTF	19.5	11	D	50
360-081-038-005C	25	M18 x 1.5	20.5	12	A	50
360-081-038-008C	28	1/8" - 27 NPTF	19.5	11	A	50
<b>FOR DUAL UNITS (IDENTIFIED WITH "D")</b>						
362-081-001-001K*	5	1/8" - 27 NPTF	19.5	11	B	30
362-081-001-002C/K*	10	1/8" - 27 NPTF	19.5	11	B	30
362-081-002-001K*	25	1/8" - 27 NPTF	19.5	11	B	50
362-081-002-003C*	28	1/8" - 27 NPTF	19.5	11	A	50
362-081-002-004C*	28	1/8" - 27 NPTF	19.5	11	D	50

\* Half characteristic curve values

1 Without Hexagonal nut M4

## 2.2.4 Pressure Sensors with Warning Contact (3 connections)

### Circuit diagram

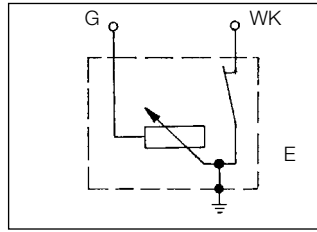
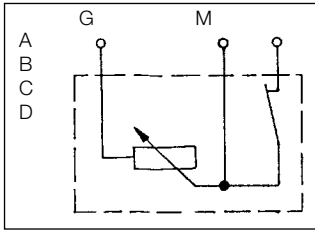

G = Sensor  
M = Ground (Masse)  
WK = Warning contact (Warnkontakt)

### Types of connection

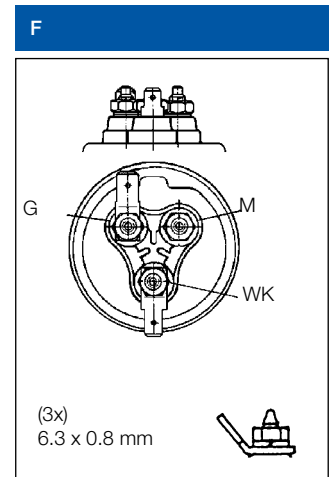
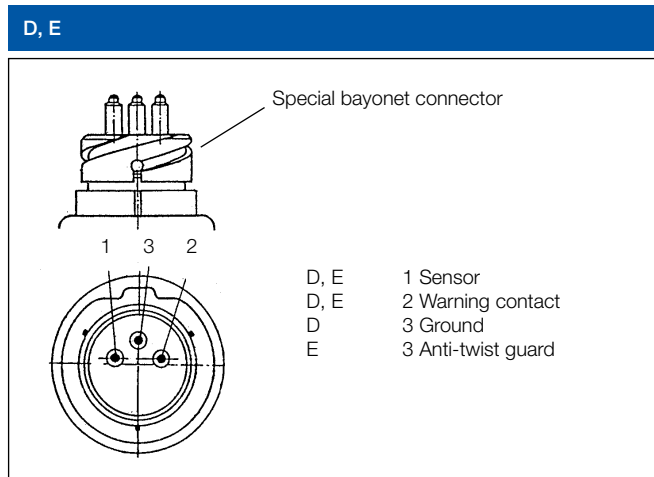
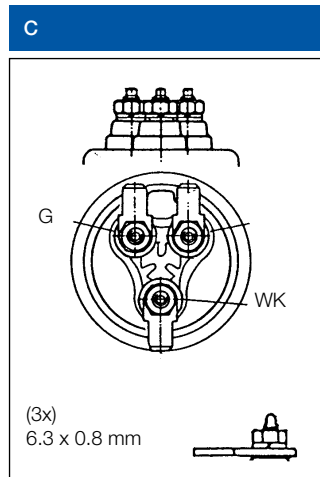
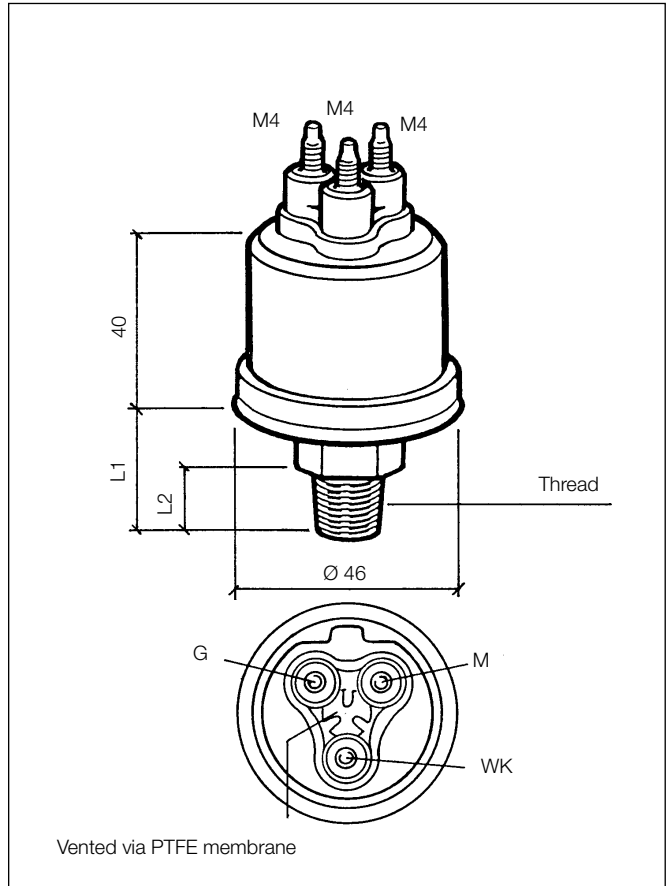
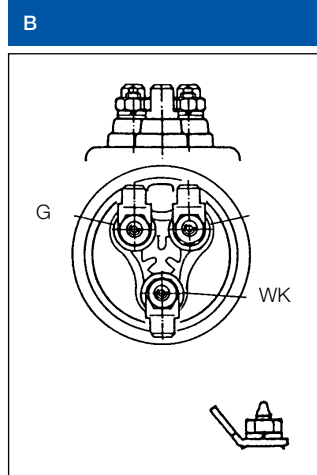
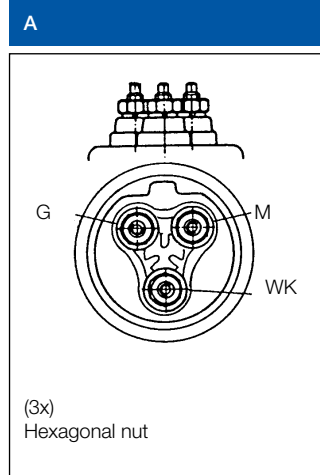

Order Part No.	Measuring range	Thread	Warning contact	Dimensions		Type	bar
	[bar]		[bar]	L1 [mm]	L2 [mm]		[max. 2 sec.]
360-081-039-002C	5	1/8" - 27 Dryseal NPTF	0.8 ±0.15	19.5	11	B	30
360-081-039-015C	5	1/8" - 27 Dryseal NPTF	0.25 <sup>+0.15</sup>	19.5	11	B	30
360-081-064-001C	5	M18 x 1.5	0.25 <sup>+0.15</sup>	20.5	12	E	30
360-081-064-003C	5	M18 x 1.5	0.25 ±0.15	20.5	12	D, E	30
360-081-039-003C	10	1/8" - 27 Dryseal NPTF	0.8 ±0.15	19.5	11	B	30
360-081-039-007C	10	M14 x 1.5	1.0 ±0.15	20.5	12	A <sup>1</sup>	30
360-081-063-001C	10	M12 x 1.5	5.2 ±0.3	20.5	12	D	30
360-081-064-004C	10	M18 x 1.5	0.6 <sup>+0.3</sup>	20.5	12	E	30
360-081-063-003C	16	M18 x 1.5	5.5 <sup>+0.3</sup>	20.5	12	D	30

\*On request - limited availability

Order Part No.	Measuring range	Thread	Warning contact	Dimensions		Type	bar
	[PSI]		[PSI]	L1 [mm]	L2 [mm]		[ max. 2 sec.]
360-081-039-004C	80	1/8" - 27 Dryseal NPTF	10 ±2	19.5	11	C	40

<sup>1</sup> Without Hexagonal nut M4

Technical characteristics	
Voltage	6–24 V
Warning contact	CLOSES with falling pressure
Switching capacity of warning contact	Max. 5 W non-inductive
Operating temperature	from -25 °C to +100 °C
Resistive range	from 10 Ω to 184 Ω





## 2.3 Pressure Switches

2.3.1 Pressure Switches, single pole, common ground

2.3.2 Pressure Switches, insulated return

## 2.3.1 Pressure Switches, single pole, common ground

**Design 1**

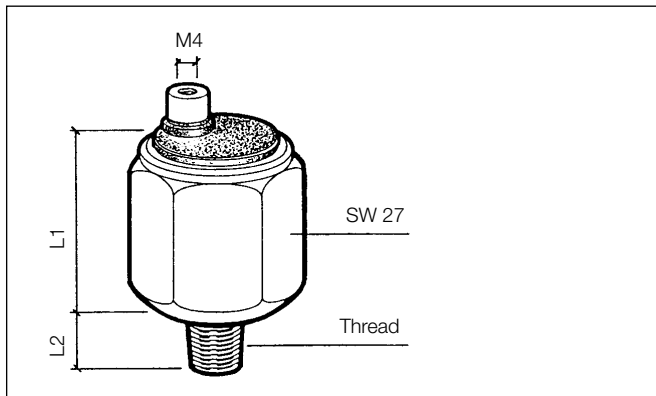

**Design 2**

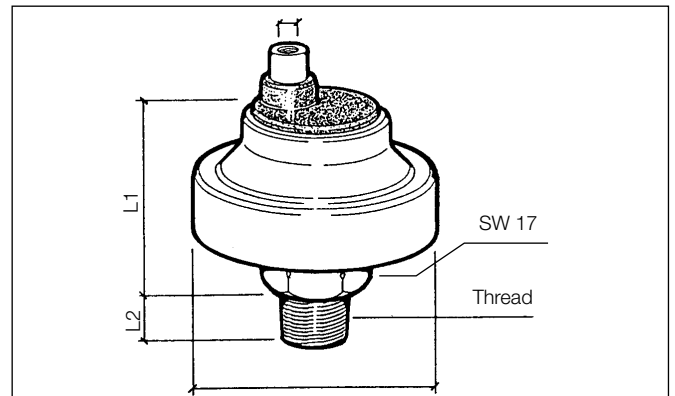

### Types of connection

A	B	C
Single-Pole, Common ground	Single-Pole, Common ground	Single-Pole, Common ground
<p>Screw M4 x 5</p>	<p>Screw M4 x 5</p> <p>6.3 x 0.8 mm</p>	<p>6.3 x 0.8 mm Riveted</p>

Order Part No.	Switching point		Thread	Dimensions		Design / Type of connection	Measuring range	bar
	[bar]			L1 [mm]	L2 [mm]			
230-112-001-004C	0.4 ± 0.3	SS	M10 x 1 tapered, short	26	11	1A <sup>2</sup>	12	30
230-113-001-004C	0.4 ± 0.2	SF	M10 x 1 tapered, short	39	11	2A <sup>1</sup>	12	30
230-112-003-015C	0.5 ± 0.1	SF	M10 x 1 tapered, short	26	11	1A <sup>1</sup>	12	30
230-112-001-015C	0.9 ± 0.15	OF	M10 x 1 tapered, short	26	11	1A <sup>2</sup>	12	30
230-112-003-022C	0.9 ± 0.15	SF	M10 x 1 tapered, short	26	11	1A <sup>2</sup>	12	30
230-112-001-001C	1.0 ± 0.2	SS	M10 x 1 tapered, short	26	11	1A <sup>2</sup>	12	30
230-112-001-005C	2.5 ± 0.3	SS	M10 x 1 tapered, short	26	11	1A <sup>2</sup>	12	30
230-113-001-008C	5.5 ± 0.2	SF	M12 x 1.5	39	12	2C <sup>2</sup>	10	30
230-213-001-021C	8.0 ± 0.5	SF	M10 x 1 tapered, short	39	11	2A <sup>2</sup>	25	50
230-213-001-011C	12.0 ± 0.4	SF	1/8" - 27 NPTF	39	11	2B <sup>2</sup>	18	40

<sup>1</sup>Contact chamber, vented

<sup>2</sup>Contact chamber, unvented

Order Part No.	Switch point		Thread	Dimensions		Type of connection	Measuring range	PSI
	[PSI]			L1 [mm]	L2 [mm]			
230-112-003-012C	6	SF	1/8" - 27 NPTF	26	11	1A1	12	30
230-112-001-002C	10	SS	1/8" - 27 NPTF	26	11	1A1	12	30
230-112-003-013C	10	SF	1/8" - 27 NPTF	26	11	1A1	12	30

<sup>1</sup>Contact chamber, unvented

### Technical characteristics

Voltage	6–24 V
Switching capacity	Max. 5 W non-inductive
Contacting mode	Slow-acting
Operating temperature	-from 25 °C to +120 °C
Switching point	SF = Contact closes with falling pressure SS = Contact closes with rising pressure OF = Contact opens with falling pressure OS = contact opens with rising pressure

## 2.3.2 Pressure Switches, insulated return

### Design 1

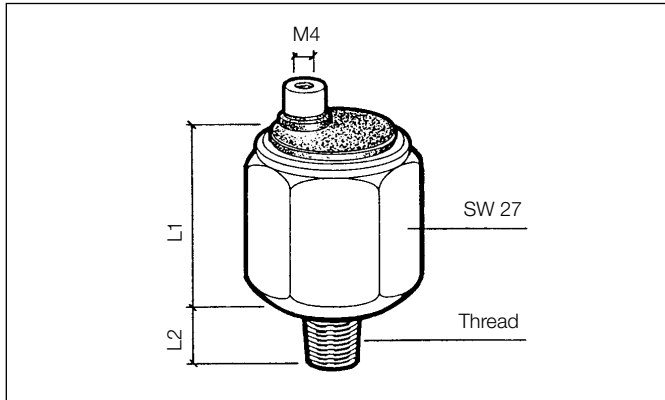

### Design 2

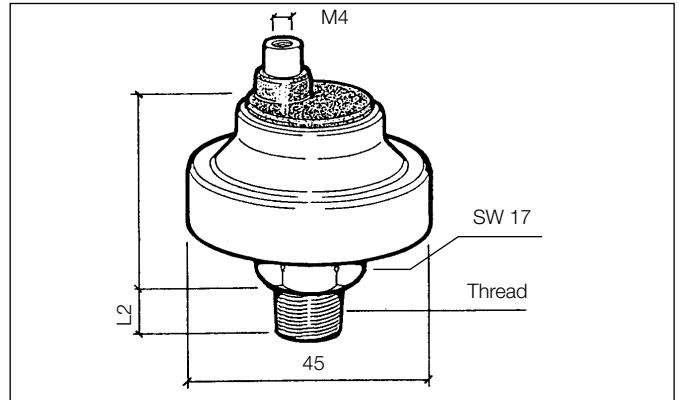

### Types of connection

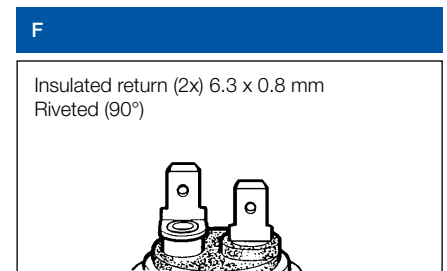
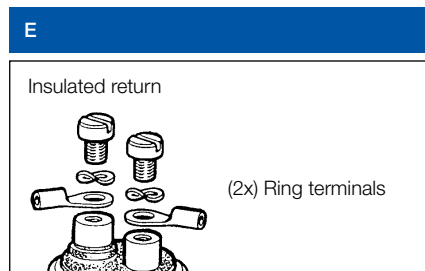
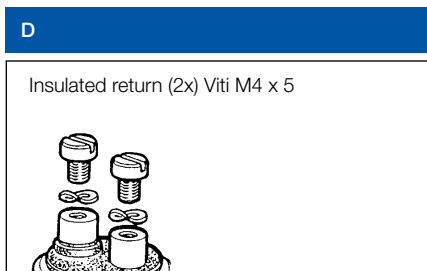

Order Part No.	Switch point		Thread	Dimensions		Design / Type of connection	Measuring range		bar
	[bar]			L1 [mm]	L2 [mm]		[bar]	[max. 2 sec.]	
230-112-007-005C	0.3 ±0.15	OS	M14 x 1.51	24.5	12	1F3	12	30	
230-112-002-001C	0.5 ±0.2	SS	1/8" - 27 NPTF	26	11	1D3	12	30	
230-112-005-006C	0.5 ±0.2	SF	M10 x 1 tapered, short	26	11	1F	12	30	
230-112-005-005C	0.8 ±0.2	SF	M10 x 1 tapered, short	26	11	1D2	12	30	
230-112-005-001C	1.0 ±0.2	SF	M10 x 1 tapered, short	26	11	1D2	12	30	
230-112-005-012C	1.2 ±0.2	SF	M10 x 1	24.5	10.5	1F	12	30	
230-112-005-011C	1.5 ±0.2	SF	M10 x 1 tapered, short	26	11	1E2	12	30	
230-112-005-003C	1.8 ±0.2	SF	M10 x 1 tapered, short	26	11	1E2	12	30	
230-112-005-004C	3.0 ±0.4	SF	M10 x 1 tapered, short	26	11	1D2	10	30	
230-213-002-004C	4.5 ±0.3	SF	M10 x 1 tapered, short	38	11	2D2	10	30	
230-213-002-001C	7.0 ±0.3	SF	1/8" - 27 NPTF	39	11	2E2	12	30	
230-213-002-003C	10.5 ±0.3	SF	1/8" - 27 Dryseal NPTF	39	11	2F	12	30	
230-213-004-002C*	12.5 ±0.4	SS	M14 x 1.5	39	12	1F	12	40	

1 With sealing washer, captive  
 2 Contact chamber, vented  
 3 Contact chamber, unvented  
 \* on request - limited availability

Order Part No.	Switch point		Thread	Dimensions		Type of connection	Measuring range		PSI
	[PSI]			L1 [mm]	L2 [mm]		[PSI]	[max. 2 sec.]	
230-112-005-010C	7 ±0.2	SF	1/8" - BSPF	26	10	1D1	12	30	

1 Contact chamber, vented

Technical characteristics	
Voltage	6–24 V
Switching capacity	5 W non-inductive
Contacting mode	Slow-acting
Operating temperature	from -25 °C to +120 °C
Switching point	SF = Contact closes with falling pressure SS = Contact closes with rising pressure OF = Contact opens with falling pressure OS = contact opens with rising pressure



## 2.4 Temperature Sensors

2.4.1 Temperature Sensors, Single-Pole, Common ground

2.4.2 Temperature Sensors, 2 Pole, Insulated return

2.4.3 Temperature Sensors with IP connector

2.4.4 Temperature Sensors with Warning contact

2.4.5 Air Temperature Sensor

2.4.6 Temperature Sensors, Special version

2.4.7 Pyrometer

## 2.4.1 Temperature Sensors, Single-Pole, Common ground

### Types of connection

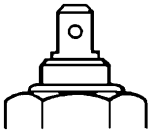
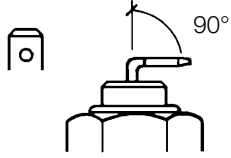
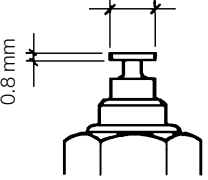
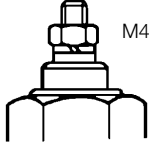
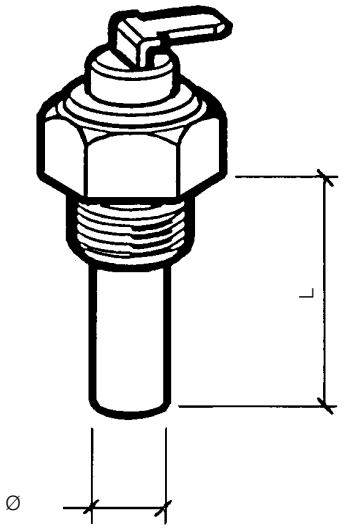
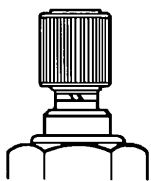
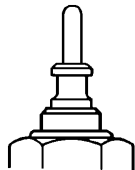
A	B	C	D
<p>Single-Pole, Common ground 6.3 x 0.8 mm</p> 	<p>Single-Pole, Common ground 6.3 x 0.8 mm</p> 	<p>Single-Pole, Common ground Ø 6.3 mm 0.8 mm</p> 	<p>Single-Pole, Common ground Hexagonal nut M4</p> 
E	F		
<p>Single-Pole, Common ground Knurled nut, M4</p> 	<p>Single-Pole, Common ground Ø 4 mm</p> 		

  

Technical characteristics	
Type of connection	Termistor (NTC)
Voltage	6–24 V
Response time	Min. 3 minutes after operating current switching ON

Order Part No.	Characteristic curve (KT)	T max.	Thread	Type of connection	L	Ø
		[°C]			[mm]	[mm]
323-801-001-006K/N	1	120	M14 x 1.5	A	29	9
323-801-001-007N	1	120	3/8" - 18 NPTF	A	29	9
323-801-001-008N	1	120	5/8" - 18 UNF-3A	A	29	9
323-801-001-009N	1	120	1/4" - 18 NPTF	A	29	9
323-801-001-010K/N	1	120	1/2" - 14 NPTF	A	29	9
323-801-001-022N	1	120	M18 x 1.5	A	29	9
323-801-001-026K/N	1	120	M14 x 1.5	A	29	9
323-801-001-029N	1	120	M16 x 1.5	A	29	9
323-801-001-040N	1	120	M16 x 1.5	A	29	9
323-801-001-054D	1	120	M14 x 1.5	D	29	9
323-801-001-058C	1	120	R 3/8" (DIN 2999 tapered )	E	29	9
323-801-005-001D	7	120	1/8" - 27 NPTF	C	22	8.5
323-801-005-005D	1	120	M10 x 1	C	22	8.5
323-801-008-002D	13	120	M10 x 1	D	22	8.5
323-801-017-001K/N	1	120	M10 x 1, tapered, short	A	10.5	8.4
323-801-020-002D	1	120	M14 x 1.5	F	24	9
323-801-028-001C	10	probe: 250, hex. 150	M14 x 1.5	C	57	11.8
A2C1754920001	2	150	M14 x 1.5	A	29	9
323-801-004-003D	2	150	R 1/2	A	29	9
A2C1755240001	2	150	1/2" - 14 NPTF	D	29	9
A2C1755260001	2	150	1/2" - 14 NPTF	A	29	9
323-801-004-012C	2	150	M16 x 1.5	E	29	9
A2C1755340001	2	150	1/4" - 18 NPTF	D	29	9
A2C1754930001	2	150	M14 x 1.5	B	29	9
A2C1755370001	2	150	1/8" x 27 NPTF	C	22	8.2
A2C1755380001	2	150	M10 x 1, tapered, short	C	22	8.2
A2C1755400001	2	150	M10 x 1.5	C	22	6.9
A2C1755410001	2	150	M12 x 1.5	C	22	6.9
A2C1755430001	2	150	M16 x 1.5	B	15	9
A2C1755440001	2	150	M14 x 1.5	B	15	9
A2C1755460001	2	150	M18 x 1.5	B	15	9
323-801-003-001D	12	200	M10 x 1.5	C	22	6.9
323-801-018-001D	12	200	1/8" x 27 NPTF	C	10.5	8.4
323-801-013-001D	12	200	1/8" x 27 NPTF	C	22	8.2

## 2.4.2 Temperature Sensors, 2 Pole, Insulated return

### Types of connection

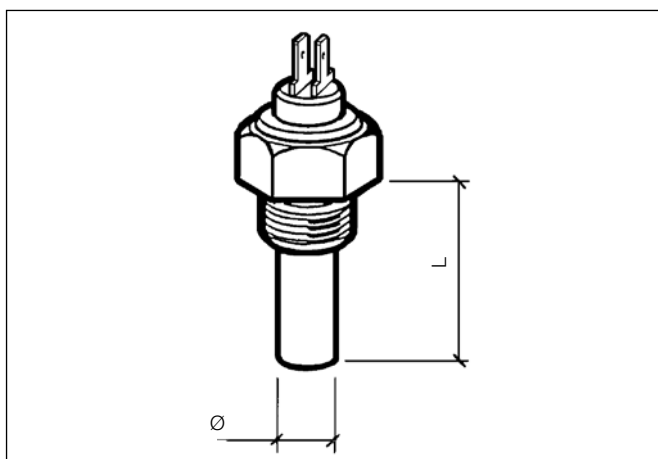
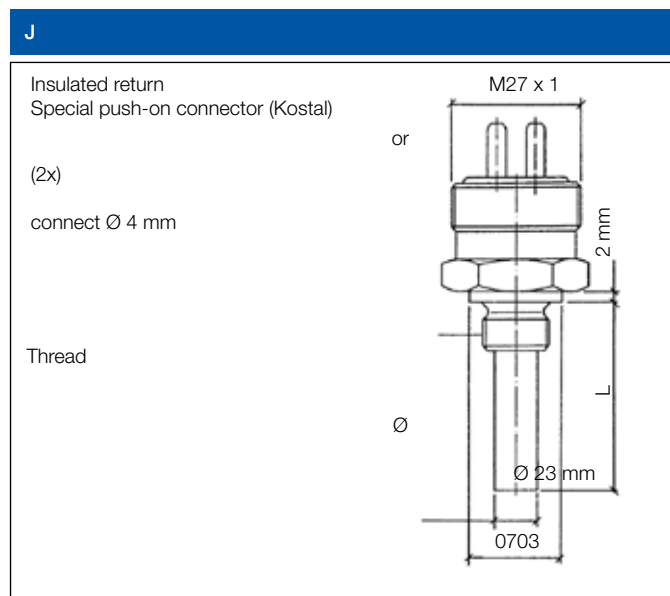
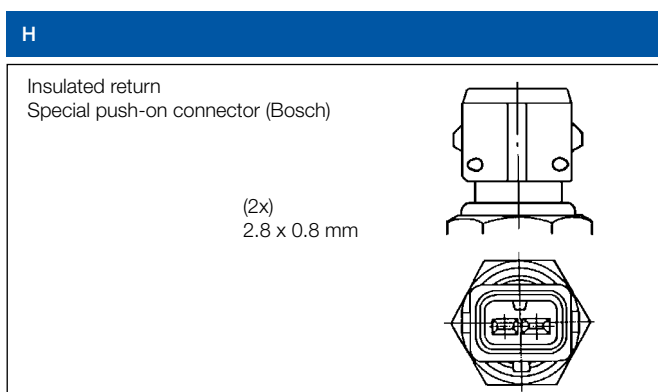
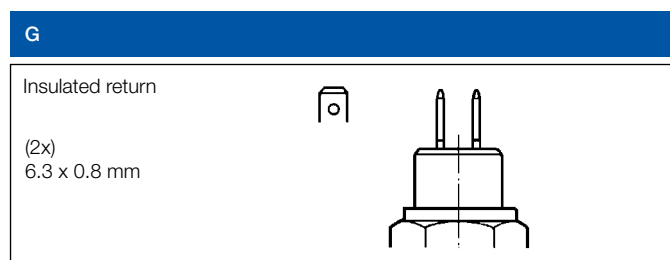

Order Part No.	Characteristic curve (KT)	T max.	Thread	Type of connection	L	Ø
		[°C]			[mm]	[mm]
323-805-001-001K/N	1	120	M14 x 1.5	G	29	11
323-805-001-002C	1	120	5/8" - 18 UNF-2A	G	24	11
323-805-001-004K/N	1	120	1/2" - 14 NPTF	G	29	11
323-805-001-005N	1	120	3/8" - 18 Dryseal NPTF	G	29	11
323-805-001-015N	1	120	M18 x 1.5	G	29	9
323-805-034-002B	18	120	M14 x 1.5	H	29	7.5
323-805-039-001C	11	120	M14 x 1.5	H	29	8.5
323-805-042-001C	15	120	M14 x 1.5	H	29	8.5
323-805-017-002C	9	130	M14 x 1.5		29	8.5
A2C1988480001	2	150	M14 x 1.5	G	29	11
A2C1988490001	2	150	1/4" - 18 NPTF	G	29	11
A2C1988520001	2	150	5/8" - 18 UNF-2A with sealing cone	G	29	11

### FOR DUAL UNITS (IDENTIFIER "D")

325-805-003-001C		120	1/4" - 18 NPTF	G	29	10.9
325-805-003-003C		120	3/8" - 18 NPTF	G	29	10.9

### Technical characteristics

Type of connection	Termistor (NTC)
Voltage	6–24 V
Response time	Min. 3 minutes after operating current switching ON

## 2.4.3 Temperature Sensors with IP connector

Part-No.	A2C59900813	A2C59515306	A2C59515307	A2C59900816
Temperature range	from -40°C to +150°C	from -40°C to +140°C	from -40°C to +130°C (+150°C for 10 min)	from -40°C to +130°C
Type of connection di fluido	Olio motore, Engine coolant, Diesel	Engine coolant	Engine coolant	Engine coolant
IP protection class	IP69K with connector inserted (IP6x dust, IP69K water)	IP69K with connector inserted (IP6x dust, IP69K water)	IP69K with connector inserted (IP6x dust, IP69K water)	IP69K with connector inserted (IP6x dust, IP69K water)
Connector	Bosch S204 714-000 2 pole code 2	Bosch S204 714-000 2 pole code 1	Kostal 1 00 50 54434 0 2 pole code A	Tyco C 282 190
Connector counterpart	Bosch1928403920 Code 2 Contact 2	Delphi DRW. 152624 way2 code 1	Receptacle Leopold Kostal (nero) 2 pole code A, 09 4412 11, Contact SLK 8 ELA TAB 2 99 00 47295 0	Tyco AMP925597-2 or AMP925596
Material and color of the connector	PA66 GF 30 / grey	PA66 GF 30 / black	PA66 GF 30 / black	PA66 GF 30 / blue
Recommended application	Truck, bus, generators	Passenger vehicles, generators	Truck, bus, generators, marine engines	Passenger vehicles, generators, bikes, small marine engines
Characteristic resistance	60°C: 7556 ± 378,0 Ω 90°C: 2803,6 ± 140,2 Ω 120°C: 1191 ± 59,5 Ω 150°C: 562,7 ± 36 Ω	60°C: 546,7 ± 23,6 Ω 90°C: 205,4 ± 10,2 Ω 120°C: 88,2 ± 5,0 Ω	60°C: 593,8 ± 19,3 Ω 90°C: 244,1 ± 4,7 Ω 120°C: 113,7 ± 3,0 Ω	60°C: 703,8 ± 40,9 Ω 90°C: 260,7 ± 15,1 Ω 120°C: 111,1 ± 7,8 Ω
Material of the contact surface	11SMnPb30	CuZn39Pb3 R430	CuZn39Pb2F43	11SMnPb30
Hexagon	Hex21	Hex21	Hex22	Hex21
Thread	M12 x 1,5	M12 x 1,5	M14 x 1,5	M12 x 1,5
Weight	23g	25g	41g	29g
O-Ring	FMP (Shore A70 ± 5)	copper	No	EN AW - 1200 (Al99)
Tightening torque	from 15Nm to 20Nm	17Nm ± 3Nm - 0Nm	max. 45Nm	20Nm ± 10%

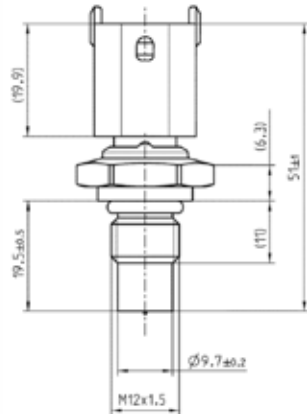

A2C59900813

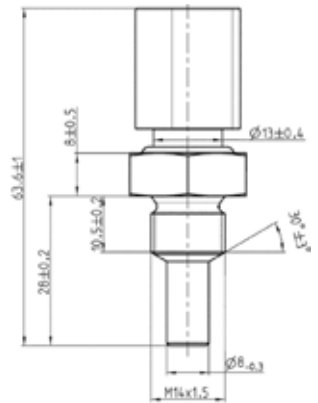

A2C59515307

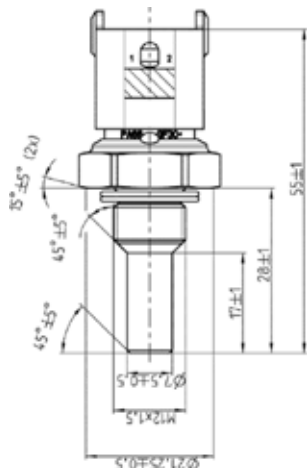

A2C59515306

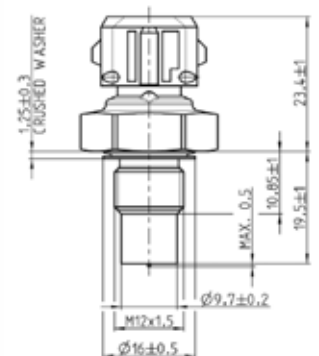

A2C59900816



## 2.4.4 Temperature Sensors with Warning contact

### Types of connection

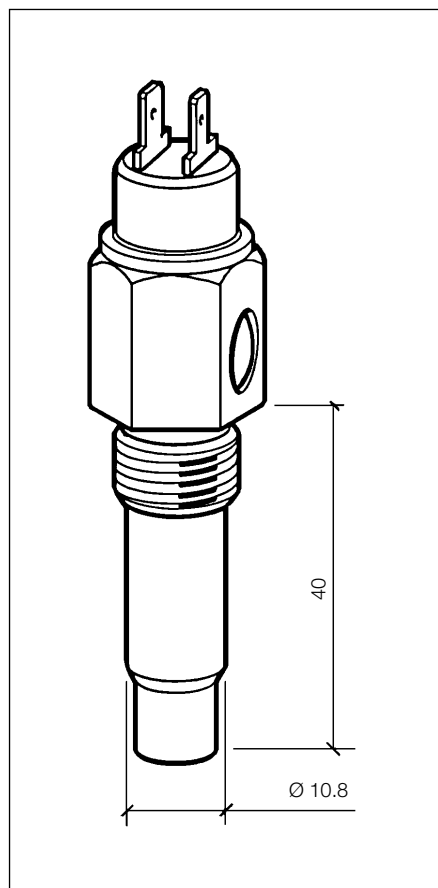
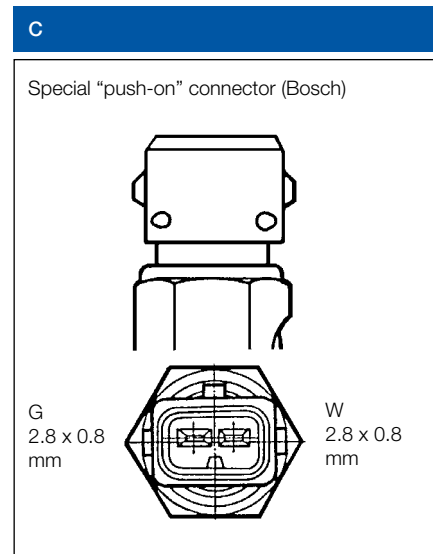
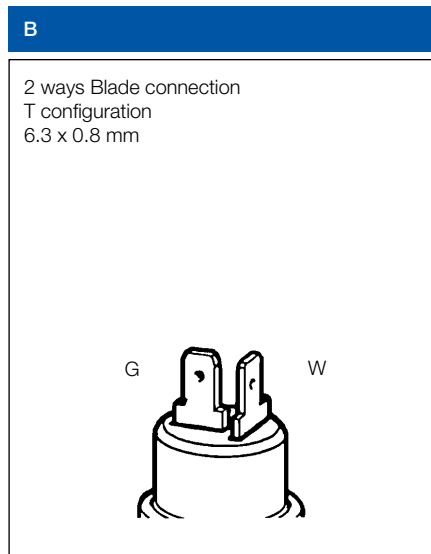
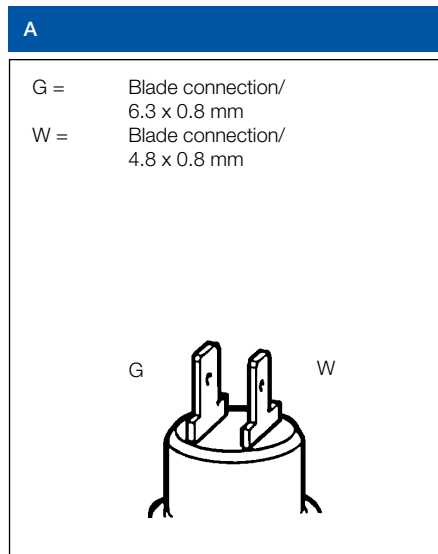

G = Sensor  
W = Warning contact

#### Technical characteristics

Type of connection	Termistor (NTC)
Voltage	6–24 V
Response time	Min. 3 minutes after operating current switching ON
Switching capacity	1.2 W to 3 W, non-inductive
Punto di switch OFF	Max. 5 °C below the Switching point
Contacting mode	Slow-acting
Type of contact connection	Normally OPEN
	The contact CLOSES with rising temperature

Order Part No.	Characteristic curve (KT)	T max.	Thread	Switching point	Type of connection
		[°C]		[°C]	
323-803-001-001D/K	1	120	M14 x 1.5	100 ±3	A
323-803-001-002D	1	120	5/8" - 18 NF-3	98 ±3	A
323-803-001-004D	1	120	M14 x 1.5	90 ±3	A
323-803-001-006D	1	120	M14 x 1.5	96 ±3	A
323-803-001-007D	1	120	M14 x 1.5	110 ±3	A
323-803-001-008D	1	120	M14 x 1.5	110 ±3	A
323-803-001-009D	1	120	M14 x 1.5	102 ±3	A
323-803-001-011D	1	120	5/8" - 18 NF-3	95 ±3	A
323-803-001-012D	1	120	5/8" - 18 NF-3	100 ±3	A
323-803-001-013D	1	120	M14 x 1.5	106 ±3	A
323-803-001-016D	1	120	M14 x 1.5	94 ±3	A
323-803-001-019D	1	120	1/2" - 14 NPTF	95 ±3	A
323-803-001-020D/Z	1	120	M14 x 1.5	115 ±3	A
323-803-001-022D	1	120	M14 x 1.5	118 ±3	A
323-803-001-023D	1	120	M14 x 1.5	80 ±3	A
323-803-001-025D	1	120	1/2" - 14 NPTF	103 ±3	A
323-803-001-028D	1	120	M14 x 1.5	98 ±3	A
323-803-001-030D	1	120	1/2" - 14 NPTF	100 ±3	A
323-803-001-032D	1	120	1/2" - 14 NPTF	108 ±3	A
323-803-001-036D	1	120	5/8" - 18 NF-3	103 ±3	A
323-803-001-059D	1	120	5/8" - 18 NF-3	105 ±3	A
323-803-001-060D	1	120	1/2" - 14 NPTF	105 ±3	A
323-803-001-064C	1	120	M14 x 1.5	112 ±3	A
323-803-004-001D	1	120	M14 x 1.5	100 ±2.5	B
323-803-004-002D	1	120	M14 x 1.5	105 ±3	B
323-803-004-003D	1	120	M14 x 1.5	95 ±2.5	B
323-803-004-007D	1	120	M14 x 1.5	100 <sup>+6</sup>	B
323-803-004-011D	1	120	M14 x 1.5	105 ±3	A (90°)
A2C1755470001	2	150	M14 x 1.5	120 ±3	A
A2C1755480001	2	150	M14 x 1.5	130 ±3	A
323-803-002-010C	2	150	M14 x 1.5	135 ±3	A
A2C1755510001	2	150	M14 x 1.5	130 ±3	A
A2C1755520001	2	150	M14 x 1.5 <sup>1</sup>	120 ±3	A
323-803-002-019D	2	150	M14 x 1.5	135 ±3	A
323-803-002-020D	2	150	M14 x 1.5	110 ±3	A
323-803-006-002C	2	150	M14 x 1.5	130 ±4	B
323-803-014-002D	4	150	M14 x 1.5	130 ±3	A

<sup>1</sup>With sealing ring, captive

\*On request, limited availability

THREAD ADAPTERS		
Order Part No.	Internal thread	External thread
A2C59517951	14x1.5 mm	1/2" - 14NPTF
A2C59517952	14x1.5 mm	3/8"

## 2.4.5 Air Temperature sensor

### SENSOR WITH PROBE

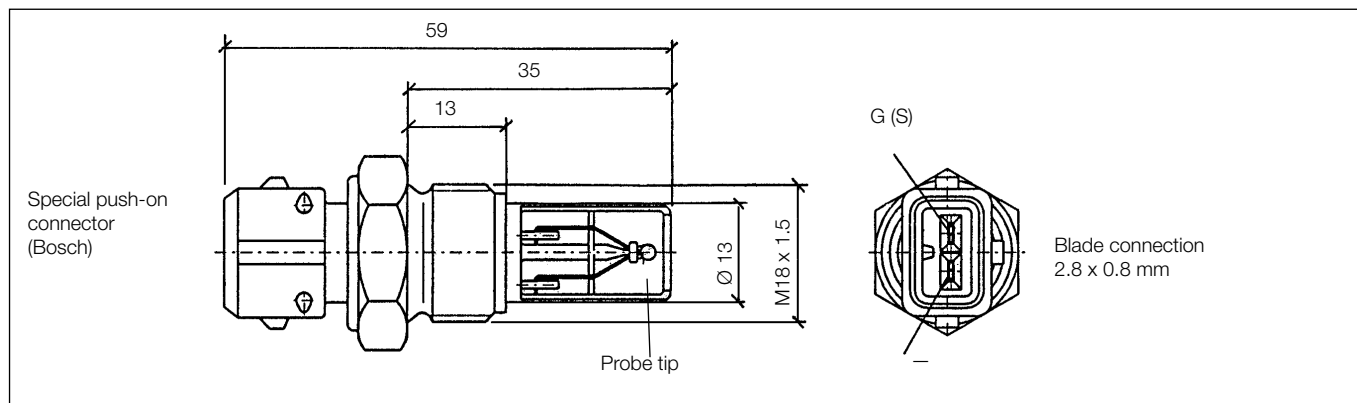

Order Part No.: 323-809-019-003A

#### Technical characteristics

Type of connection	Termistor (NTC), Insulated return
Voltage	6–24 V
Operating temperature	from -40 °C to +150 °C max. on the probe tip
Response time	Min. 3 minutes after operating current switching ON

## 2.4.6 Temperature Sensor (special version)

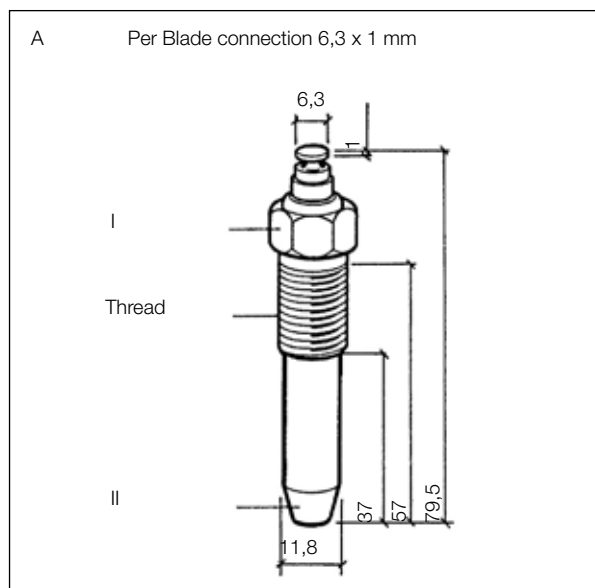

#### Technical characteristics

Version	Termistor, 1-pole Common ground
Voltage	from 6V to 24V
Response time	Min. 3 minutes after operating current switching ON
Operating values	Operation with indicating instrument: 210°C = 18.9Ω ± 1.3Ω Operation with control electronics: 210°C = 20.05Ω ± 0.80Ω

Operating temperature		Thread	CT	Type	Order Part No.
Measuring point I	Measuring point II				
-40°C ... +150°C	-40°C ... +250°C	M14 x 1,5	14	A	323-801-028-001C

## 2.4.7 Pyrometer

Dimensions (mm):

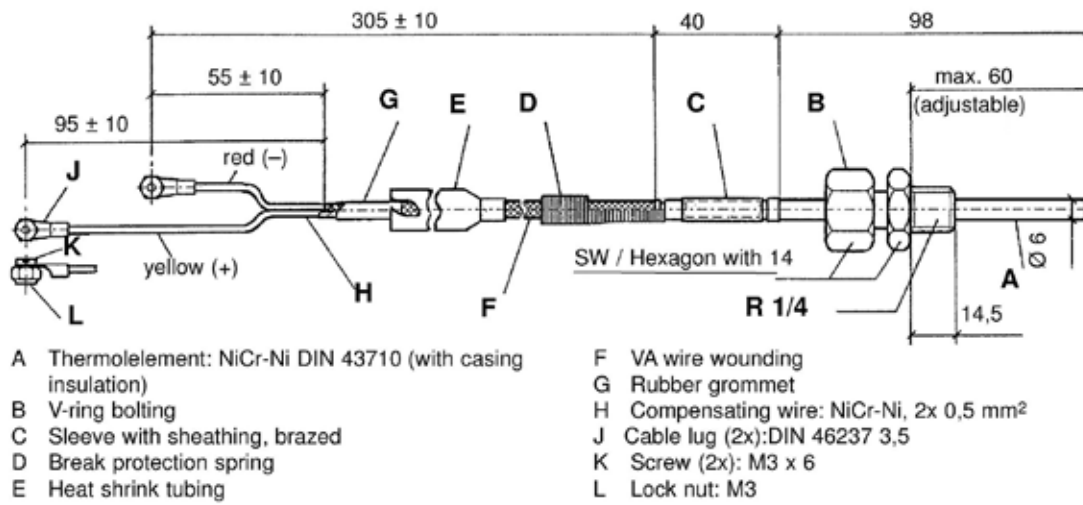

Order Part No.: N03-320-264

Connection cable dimensions:

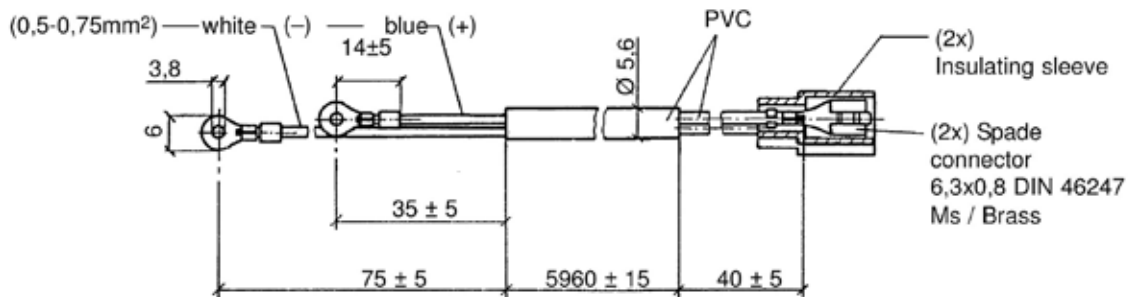

Order Part No.: N03-320-268

Dimensions of threaded bushing (steel) for the welding to the manifold

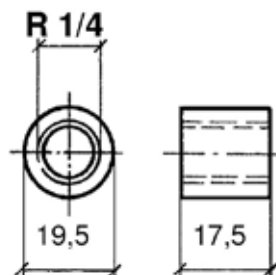

Order Part No.: N03-320-266



## 2.5 Temperature Switches

2.5.1 Temperature Switches, single pole, common ground

2.5.2 Temperature Switches, 2 pole, Insulated return

## 2.5.1 Temperature Switches, single pole, common ground

### Types of connection

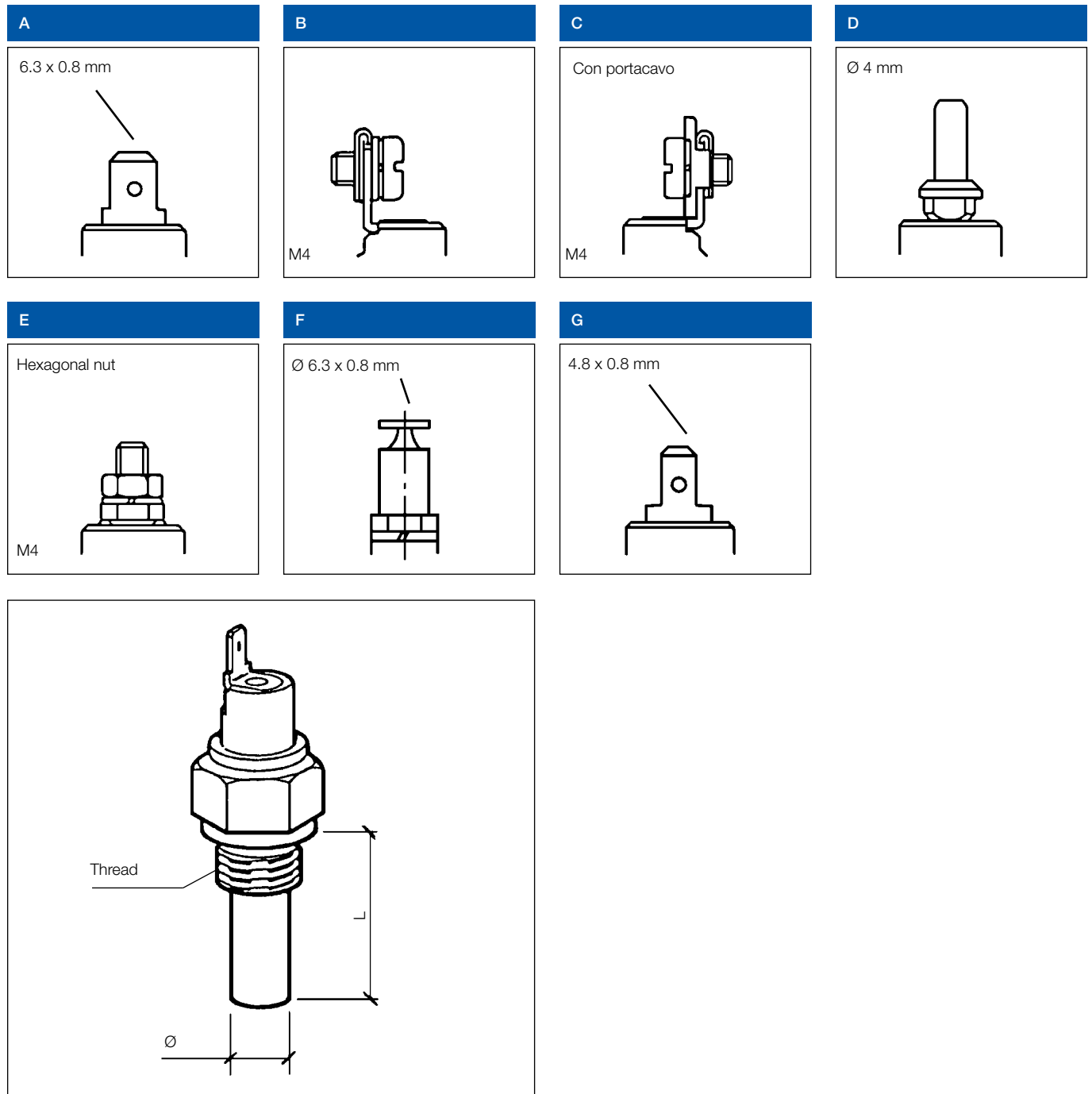

Order Part No.	Switching point	Switch mode	Thread	T max.	Type	L	Ø
	[+ °C]			[°C]		[mm]	[mm]
232-011-020-022E	16 ±3 (normally closed, NC)	OS	M14 x 1.5	120	D	29	10
232-011-020-006E	25 ±3 (normally closed, NC)	OS	M14 x 1.5	120	D	29	10
232-011-017-141D	28 ±3 (normally closed, NC)	OS	M14 x 1.5	120	A	29	9.7
232-011-017-129D	35 ±3	SS	M14 x 1.5	120	A	29 ±0.2	10-0.5
232-011-005-019D	96 ±3	SS	1/8" - 27 Dryseal NPFT	120	E	33 ±0.5	12 ±0.3
232-011-017-148D	35 ±3	SS	M14 x 1.5	120	A	29	10
232-011-017-087D	40 ±3	SS	M14 x 1.5	120	D	29	10
232-011-017-038D	55 ±3	SS	M14 x 1.5	120	A	29	10
232-011-017-040D	70 ±3	SS	M14 x 1.5	120	A	29	10
232-011-017-078D	80 ±3	SS	M14 x 1.5 tapered, short	120	A	29	10
232-011-017-017D	85 ±3	SS	M14 x 1.5	120	A	29	10
232-011-005-003D	90 ±3	SS	M14 x 1.5	120	E	38.5	6.9
232-011-017-013D	90 ±3	SS	M10 x 1.5 tapered, short	120	A	29	10
232-011-017-033D	92 ±3	SS	M14 x 1.5	120	A	29	10
232-011-017-147D	94 ±3	SS	M14 x 1.5	120	D	29	10
232-011-017-016D	95 ±3	SS	M14 x 1.5	120	A	29	10
232-011-017-039D	95 ±3	SS	1/2" - 14 NPTF	120	A	29	10
232-011-017-080D	97 ±3	SS	M14 x 1.5	120	A	29	10
232-011-017-099D*	98 ±3	SS	5/8" - 18 UNF-2A	120	A	29	10
232-011-017-034D	100 ±3	SS	M14 x 1.5	160	A	29	10
232-011-017-058D*	102 ±6	SS	M14 x 1.5	120	C	29	10
232-011-017-135D	102 ±3	SS	M14 x 1.5	150	D	29 ±0.2	9 ±0.2
232-011-017-139D	103 ±3	SS	3/8" - 18 NPTF	120	A	29	10
232-011-017-037D	105 ±3	SS	M14 x 1.5	120	A	29	10
232-011-017-041D	105 ±3	SS	1/2" - 14 NPTF	120	A	29	10
232-011-017-145D*	105 ±3	SS	3/8" - 18 NPTF	120	G	29	10
232-011-017-010D	110 ±3	SS	M14 x 1.5	160	A	29	10
232-011-017-076D	115 ±3	SS	M14 x 1.5	130	A	29	10
232-011-017-005D	120 ±3	SS	1/2" - 14 NPTF	130	B	29	10
232-011-017-032D	120 ±3	SS	M14 x 1.5	130	A	29	10
232-011-017-143D	120 ±3.3	SS	3/4" - 16 UNF-2A	150	A	27.1 ±0.2	9.7 ±0.2
232-011-005-015D	130 ±10	SS	M10 x 1.5	180	E	38.5	6.9
232-011-017-103D	130 ±3	SS	M14 x 1.5	150	A	29	10
232-011-005-004D	140 ±10	SS	M14 x 1.5	160	A	29	10
232-011-017-004D	140 ±10	SS	M14 x 1.5	160	A	29	10
232-011-005-017D	150 ±5	SS	M10 x 1.5	200	E	38.5	6.9
232-011-005-027D	150 ±5	SS	M10 x 1.5	200	F	38.5	6.9

Order Part No.	Switching point	Switch mode	Thread	T max.	Type	L	Ø
	[+ °C]			[°C]		[mm]	[mm]
232-011-005-004D	170 ±5	SS	M10 x 1.5	220	E	38.5	6.9
232-011-005-028D	170 ±5	SS	M10 x 1.5	220	F	38.5	6.9
232-011-005-030D	185 ±5	SS	M10 x 1.5	230	F	38.5	6.9
232-011-019-003D	195+10	SS	M10 x 1.5	250	E	38.5	6.9

\*On request, limited availability

Switching Mode:

OS = The contact OPENS as temperature rises

SS= The contact CLOSES as temperature rises

## 2.5.2 Temperature Switches, 2 pole, Insulated return

### Design

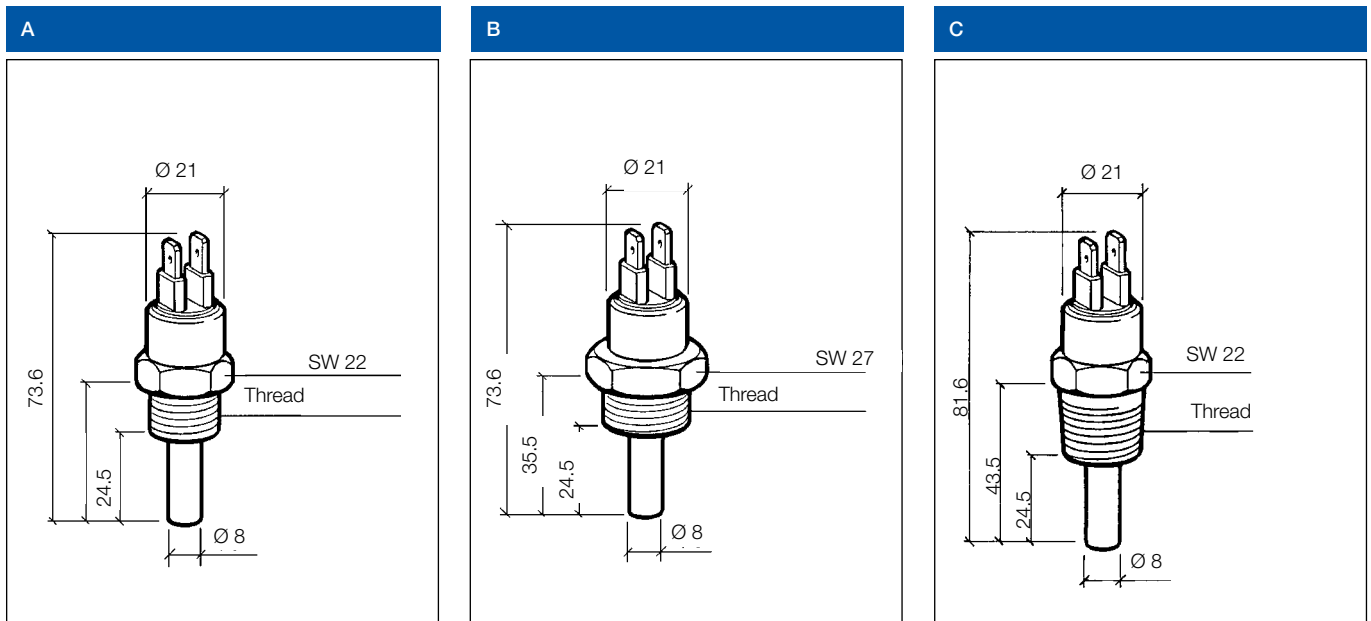

Order Part No.	Switching point (Switch ON)	Punto di rilascio (Switch OFF)	Thread	Design
	[+ °C]	[+ °C]		
232-036-005-019C*	35 ± 4 (normally closed, NC)		M14 x 1.5	
X10-232-001-001	64 ± 3	60 ± 3	M14 x 1.5	A
X10-232-001-002	82 ± 3	74 ± 3	M18 x 1.5	A
X10-232-001-003	86 ± 3	81 ± 3	M18 x 1.5	A
X10-232-001-004	92 ± 3	85 ± 3	M18 x 1.5	A
X10-232-001-005	96 ± 3	92 ± 3	M18 x 1.5	A
X10-232-001-006	96 ± 3	91 ± 3	1/2" - 14 NPTF	C
X10-232-001-007	96 ± 3	92 ± 3	M14 x 1.5	A
X10-232-001-008	96 ± 3	92 ± 3	M22 x 1.5	B
X10-232-001-009	100 ± 3	95 ± 3	M18 x 1.5	A
X10-232-001-010	105 ± 3	100 ± 3	M18 x 1.5	A

\*On request, limited availability

Technical characteristics	
Switching capacity:	100 W
<b>FOR THE MONITORING OF VARIOUS FLUIDS</b>	
Operating temperature	Max. 110 °C
Voltage	6–24 V
Switching point	Normally open The contact closes with rising temperature
Switch off point	Max. 5 °C below the Switching point
2 ways Blade connector	A 6.3 x 0.8 mm, DIN 46244





## 2.6 Liquid Level Switches

2.6.1 Liquid Level Switches, linear type, for oil/Diesel

2.6.2 Liquid Level Switches, lever type, for water

## 2.6.1 Liquid Level Switches, linear type, for oil/Diesel

### Dimensions [mm]

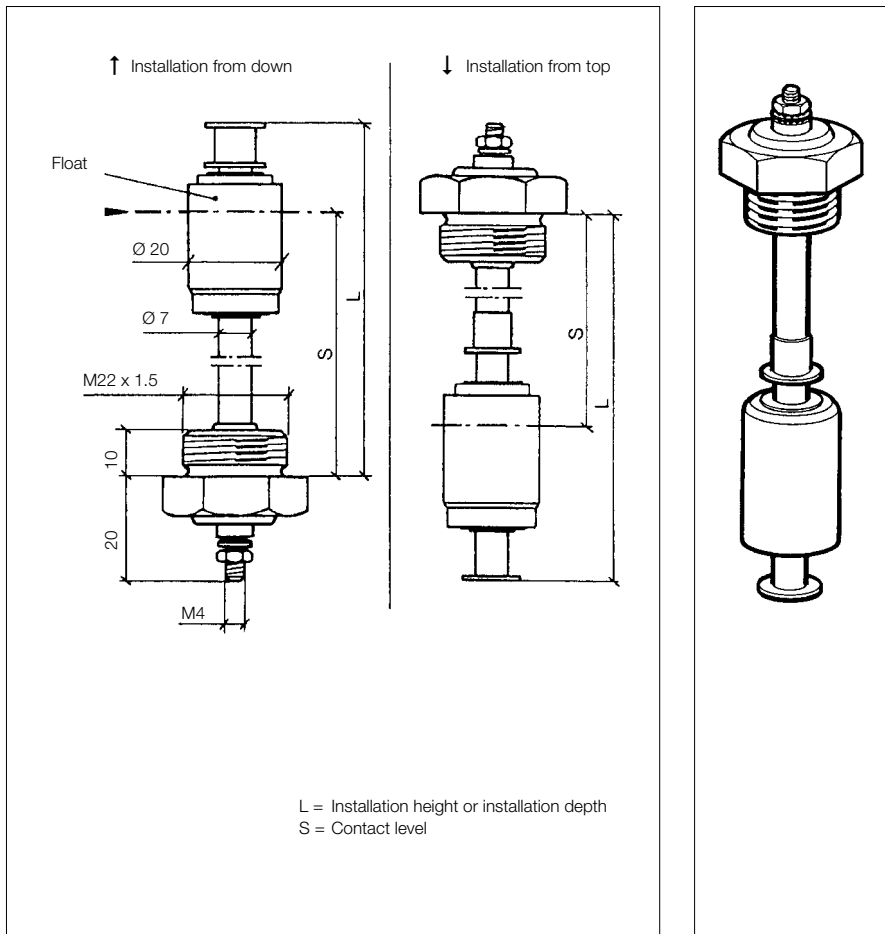

### Types of connection

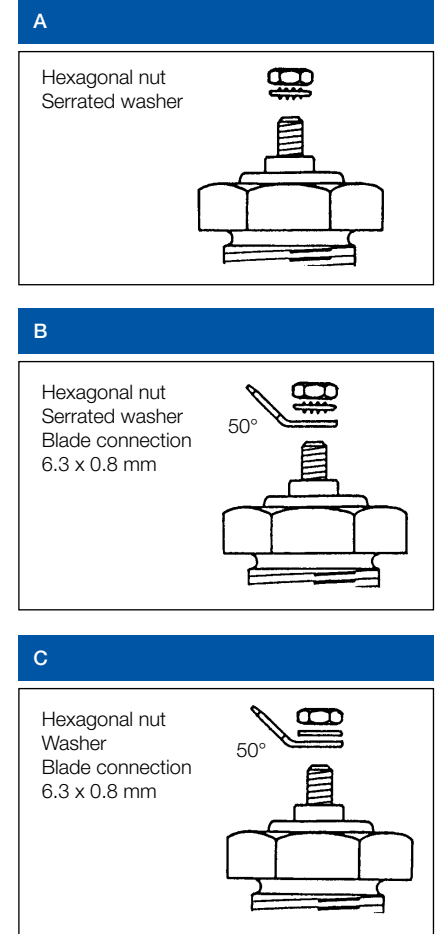

Order Part No.	Installation	L	S	Voltage	Max. Switching load	Type	Fluid
		[± 1.5 mm]	[± 3 mm]				
395-462-001-001G	↓ from top	184	158	24 V	3 W	A	Diesel/trasmission oil
395-262-001-007C	↓ from top	196	170	12 V	2 W	B	Diesel
395-262-001-023C	↓ from top	275	249	12 V	2 W	B	Diesel
395-462-001-006G	↓ from top	311	285	24 V	3 W	C	Diesel
395-262-001-013G	↓ from top	346	320	12 V	2 W	B	Diesel
395-462-001-002G	↑ from down	60.6	35.6	24 V	3 W	A	Diesel
395-262-001-005G	↑ from down	75	50	12 V	2 W	B	Diesel
395-262-001-016G	↑ from down	77.5	52.5	12 V	2 W	B	Diesel
395-262-001-015G	↑ from down	98	73	12 V	2 W	A	Diesel
395-462-001-004G	↑ from down	145	120	24 V	3 W	B	Diesel
395-462-001-005C	↑ from down	175	150	24 V	3 W	B	Diesel

### Technical characteristics

Electrical connection	Single pole Common ground
Voltage	12 V or 24 V
Max. Switching load	2 W or 3 W
Contacting mode	Closes when the level ass c f g v c <<<
Valore limite di Current	150 mA
Operating temperature	-30 °C to +100 °C

## 2.6.2 Liquid Level Switches, lever type, for water

### Dimensions [mm]

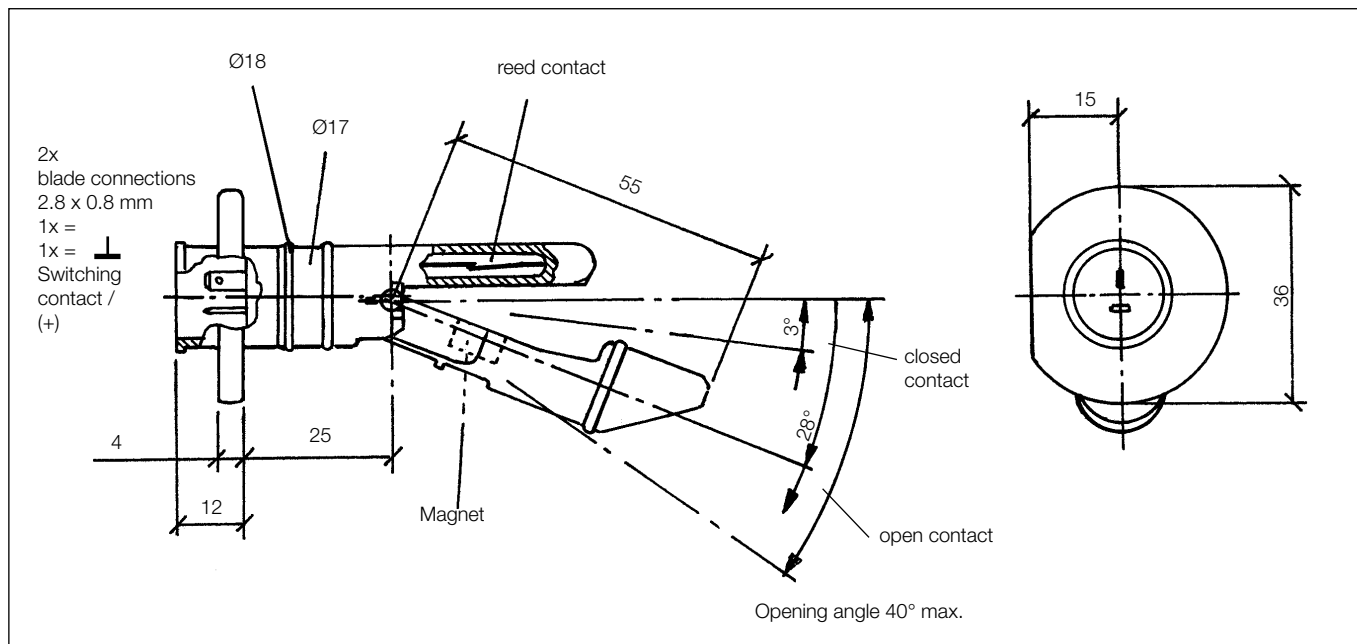

Order Part No.	Product
395-060-017-002C	Level switch
X11-000-002-173	Accessory: sealing sleeve

Technical characteristics	
Voltage	24 V
Max. Switching load	3 W
Type of contact	NO, Normally Closed
Operating temperature	from -30 °C to +100 °C
Fluid	window cleaner/Engine coolant
Resistant to:	50 % ethanol + 50 % H <sub>2</sub> O
o	50 % methanol + 50 % H <sub>2</sub> O
o	50 % antifreeze (es., Glysantin) + 50 % H <sub>2</sub> O

Pressure tight to 1.5 bar max.



## 2.7 Specific Solutions: Sensors for Engine Management Systems

2.7.1 Electronic Pressure Sensors (EPS)

2.7.2 Intake air pressure Sensors (MAP, T-MAP)

2.7.3 Mass Airflow Sensors (MAF)

2.7.4 Knock Sensor

2.7.5 Camshaft Position Sensor

2.7.6 Crankshaft Position Sensor

2.7.7 High Temperature Sensor (HTS)



### 2.7.1 Electronic Pressure Sensors (EPS)

The new sensor EPS (Electronic Pressure Sensor) is the high-performance successor of the previous generation of passive electromechanical sensors. Combining weight and small size and with greater accuracy, the EPS sensor represents the future in pressure measurement.

This innovative device utilizes the piezoresistive effect, i.e. the resistivity variations of a piezoelectric element to convert the system pressure into a proportional output signal. Depending on the choice of seal gasket material, the EPS sensor offers excellent resistance to a wide range of liquids, e.g. oil, brake fluid, diesel, petrol and engine coolant. The EPS sensor has been specially designed for high precision monitoring of engine oil pressure, transmission oil, hydraulic pressure and air. In addition to traditional automotive applications, the sensor is therefore ideal for off-road vehicles and hydraulic and pneumatic systems. The screw connection can be adapted to the individual needs of the customer. The sensor connects to the rest of the vehicle electronics via cable and plug.

#### Vantaggi:

- Direct pressure detection.
- Compatible with a wide range of liquids and gases.
- Modular design.
- Specific threading (minimum lot required).
- Specific pressure range (minimum lot required).



Electronic Pressure Sensor (EPS)

Technical Specifications:	
Pressure Range:	10 bar ... 30 bar (aluminium)
Pressure Range (possible options):	200 bar ... 600 bar (steel)
Medium:	Air, engine oil, gear oil
Voltage Supply (Vs):	da 8 VDC a 32 VDC
Output signal:	0.5 V ... 4.5 V
Temperature range:	da - 40 °C a +125 °C
Protection class:	IP 6K9K
Connector:	Bayonet, according to ISO15170 (previously DIN 72585)

Part numbers:	Pressure range
365-100-010-121K	0 - 10 bar
365-100-016-121K	0 - 16 bar
365-100-030-121K	0 - 30 bar



## 2.7.2 Intake air pressure Sensors (MAP, T-MAP)

Pressure and absolute temperature sensors, from 1 to 5 bar

Our innovative sensors help meet growing global requirements for better performance, as well as current and future emissions regulations. The absolute pressure sensors are used to measure the air pressure for different applications in the vehicle.

### Principle of operation

Our absolute pressure sensors are based on micro-machined silicon sensitive elements, which flex under load to generate a ratiometric voltage that corresponds to the incident pressure. This signal is in turn amplified and compensated in temperature according to a fully configurable digital calibration.



MAP sensor



BAP sensor



### Applications

- **MAP (Manifold Absolute Pressure Sensor):** Measurement of the intake air pressure, an important variable in the calculation of the volume of fuel to be injected and, in turn, for the optimization of the air-fuel mixture.
- **T-MAP (MAP with integrated temperature sensor):** Measurement of the pressure and temperature of the intake air flow, which are an important variable in the calculation of the volume of fuel to be injected and, in turn, for the optimization of the air-fuel mixture.
- **Turbo MAP (Manifold Absolute Pressure Sensor for Turbo engines):** Measure the air pressure downstream of the turbocharger.
- **Turbo T-MAP (Turbo MAP with integrated temperature sensor):** It measure the air pressure and temperature, for example the turbocharger.
- **BAP (Barometric Absolute Pressure Sensor):** Measure the barometric pressure of the air.
- **BPS (Brake Pressure Sensor):** Measure the air pressure in the brake servo



### 2.7.3 Mass airflow Sensor (MAF)

The growing focus on reducing CO2 emissions means that sensors measuring the flow of air in the engine are becoming increasingly important in ensuring the optimal ratio of fuel to air. The airflow sensors are positioned directly after the air filter in the intake manifold and provide information on the temperature, humidity and volume of the intake air.

In spite of their extremely compact structure, they have a precision technology to acquire information that, together with other engine data, allow to obtain the maximum performance in terms of performance and emissions

**The data includes:**

- Air intake temperature.
- Intake air humidity
- Intake air volume

In petrol engines, airflow measurement is used in combination with values provided by other sensors to adjust the fuel supply to the engine.

In diesel engines, airflow sensors are used to regulate exhaust gas recirculation and calculate the maximum amount of fuel injection.

The VDO airflow sensors are exceptionally reliable and highly resistant to adverse environmental conditions. Their dynamic measurement capability makes an important contribution to reducing vehicle emissions.



Mass Airflow Sensor (MAF)

Available only for OE applications on request



#### 2.7.4 Knock Sensor

Modern engines that work with high compression ratios have an obvious disadvantage: this characteristic leads to an increase in the possibility of detonation which can damage the engine. The sensors reliably measure the vibrations of the engine block that are caused by the detonation. This allows the ignition advance and other parameters to be set to allow the motor to function properly near the threshold.

This not only protects the engine but also reduces fuel consumption.



Knock sensor

#### 2.7.5 Crankshaft Position Sensor

The crankshaft position sensor provides information on the position of the crankshaft, and the engine management system can then calculate the rpm. This value makes it possible to determine the cheapest injection and ignition timing for the vehicle.



Crankshaft Position Sensor

#### 2.7.6 Camshaft Position Sensor

The camshaft position sensor is usually found in the engine head and reads the camshaft pinion to determine the position of the camshaft. This information is required for functions such as starting injection on sequential injection engines or the ignition signal for the injector magnet on injection systems and for detonation control of each individual cylinder.



Camshaft Position Sensor





### 2.7.7 High temperature Sensor (HTS)

The high temperature sensor plays a key role in the exhaust after-treatment process. It offers impressive long-term stability and provides high-precision temperature measurements with good linearity. The heat resistant temperature probe has many applications in innovative systems, including:

- Measurement of exhaust gas temperature for optimization of the combustion process.
- Measurement of the temperature of the exhaust gases for the protection of various components.
- Control and monitoring of diesel particulate filter systems.

The measuring range extends up to 950 ° C. Thanks to its ability to generate a reliable measurement signal under such difficult conditions, this sensor allows to provide a perfectly controlled Voltage Supply of fuel for combustion in the diesel particulate filter.

#### Benefits:

- High precision
- Minimum deterioration of the signal throughout the entire life cycle.
- Compact size
- The low thermal inertia ensures a rapid response..

Technical Specification:	
Response time:	7s @10 m/s (4s @20 m/s)
Temperature :	from -40 °C to 950 °C
Working temperature of the electronics:	from -40 °C to 140 °C
Max. temperature of the cable	250 °C
Accuracy:	from -40 °C to 50 °C ± 10 °C during lifetime from 200 °C to 650 °C ± 5 °C during lifetime > 850 °C ± 10 °C during lifetime
Voltage Supply (Vs):	24 V or 12 V
Connector:	Tyco HDSCS 4PIN 2.8 connector PN 1-1418390-1 code A
Output:	CAN SAE J1939



High Temperature Sensor (HTS)

Available only for OE applications on request



## 2.8 Differential pressure sensor (2 ports) for particulate filters

The 2-way VDO pressure sensor for diesel particle filters provides outstanding differential pressure measurement. This sensor is extremely precise and highly reliable even in the most difficult conditions, thanks to the protected positioning of the sensitive element.

Using the differential pressure measured between the filter output (P1) and the filter inlet (P2), the VDO pressure sensor is able to determine with high degree of accuracy the actual flow of exhaust gases through the diesel particulate filter and therefore the level of clogging in the filter. The sensor generates an analog output voltage proportional to the differential pressure, which is used as input by the electronic control unit (ECU). If this voltage exceeds a preset value stored in the ECU, the control unit starts a regeneration process to burn the residue in the particulate filter. This process restores the flow of gas to the original level, thus allowing optimal performance.



Differential pressure sensor

### Benefits:

- Direct pressure measurement.
- Suitable for system-internal and emissions diagnostics
- Wide measurement range.
- High accuracy and thermal stability.
- Excellent dynamic response.
- Complies with the strictest EMC requirements.
- Resistant to even highly aggressive media

### Technical specifications

Pressure range:	from 0 to 35 kPa (Delta)		
Temperature range:	from -40 to +125 °C		
Voltage Supply (Vs):	5.0 ± 0.25 VDC		
P2	Taken upstream of the particulate filter		0 kPa < P2 < 80 kPa <sup>1</sup>
P1	Taken downstream of the particulate filter		0 kPa < P1 < 40 kPa <sup>1</sup>
dP = P2 - P1	Single analog output of the differential pressure	0 kPa < dP < 35 kPa	

<sup>1</sup> (relative to the atmospheric pressure)

Available only for OE applications on request



## 2.9 Inertial Sensor

VDO is the world's first manufacturer to have built a component that brings together all the inertial sensors required in a vehicle in a single unit. Using silicon-based sensors, unwanted frequencies and interferences were eliminated, while at the same time improving resistance to vehicle vibration and extreme values of operating temperatures. The resulting inertial sensor is ideally equipped for the exacting demands of special vehicle applications.

### **Performance and safety: sensors for special vehicles**

The sensors are the eyes and ears of each vehicle; they record every movement, and prevent the occurrence of potentially dangerous situations.

Millions of these sensors are already in use, used as an integral part of modern intelligent security systems. The role of inertial sensors is to provide real-time information on rotation speed and acceleration. Those produced by VDO are specifically designed for specialized vehicle applications. Having spent many years developing sensors for passenger and commercial vehicles, VDO has the expertise to build high-precision sensors that offer exceptional reliability in the most extreme operating environments. In fact, all the qualities that your specialized vehicles require for optimum performance and safety.

### **Automatic processes, maximum security**

Adapted to the specific needs of special vehicles, the VDO inertial sensor offers many important advantages, among these the fundamental element is safety. By actively avoiding dangerous situations, the VDO inertia sensor protects the man and the machine while ensuring smooth and trouble-free operation. In addition, the sensor allows greater automation of work processes, thus increasing vehicle efficiency and productivity.

### **Accuracy, intelligence, reliability - even off-road**

The VDO inertial sensor provides a continuous measurement of all key data relating to vehicle movement. The sensor measures the rotation speed around the vertical axis and the acceleration on all three axes, ie the pitch, roll and yaw acceleration of the vehicle. Data is provided to the affected control units using the vehicle CAN J1939 standards.

When working in dangerous situations, e.g. on steep slopes, the sensor information allows greater control and thus increases safety. The sensor predicts hazards well in advance, allowing the corresponding control systems to respond accordingly, and. g. reducing vehicle speed or signaling a warning to the driver.



## Dimensions [mm]

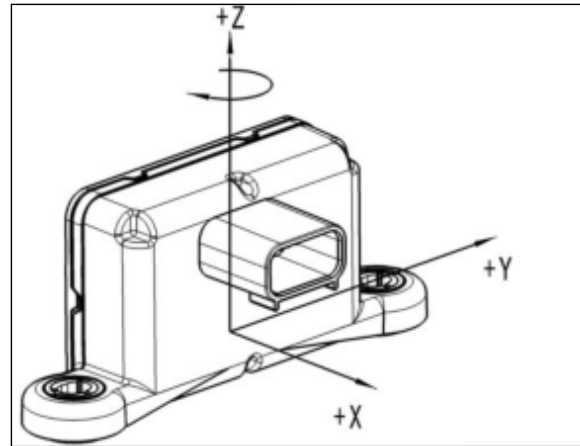
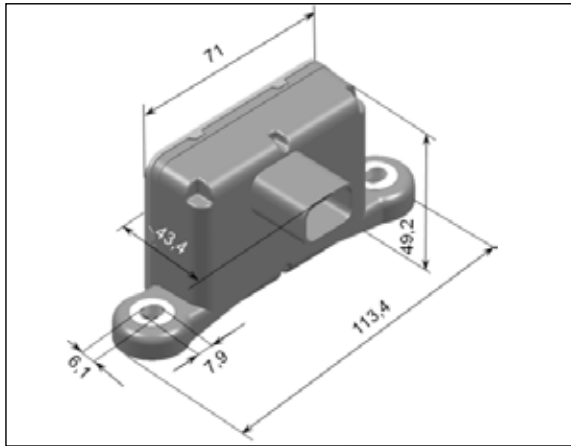

## Applications

- Roll angle calculation.
- Traction control, motion control.
- Passengers recognition
- Inclination detection
- Inertial navigation system.
- Rollover protection.
- Maintenance support functions.
- Center of gravity stabilization.
- Chassis control.
- Curve tracking light

## Key features

- Measurement directions in x-,y- and z-axis
- Measurement of angular rate (in x-y- and z axis).
- Measurement of lateral, longitudinal and vertical acceleration.
- Distribution of measurement signals on CAN.
- SAE J1939.
- Lead free component

## Technical specifications

Electrical characteristics:		
Voltage Supply	12V typ. (min. 7.2V, max. 17V)	
Supply Current	250 mA	
Operating temperature	from -40°C to +85°C	
Power ON setup time	1.5 sec.	
Signal Output Refresh rate	10ms	
Performance Characteristics:		
Sensor Type	Yaw Rate	Acceleration
Measurement Range	-100 °/s ... +100 °/s	-50 m/s <sup>2</sup> ... +50 m/s <sup>2</sup>
Measurement Direction	z-axis	x/y/z/-axis
Resolution	0.25 °s	0.05 m/s <sup>2</sup>
Mechanical characteristics:		
Housing material:	Housing PBT 1GF15, Cover PBT GF15	
Weight	62 g	
Protection class	IP6K7	
Mounting method	Fixed with M6 screws or nuts with flanges acc. DIN EN 1664-6-8	
Tightening torque	7 to 9 Nm	
Connector Type	USCAR 6-pin connector MOLEX 47715-6100 - Mating KIT available	

## Order Part NO.:

Order Part No.:	Description
A2C59514837	Inertial Sensor 4DoF (3-axis acceleration & 1 axis yaw)
A2C59507607	USCAR mating connector KIT

## Directive 2000/53/EC

The sensor cluster complies with the requirements of DIRECTIVE 2000/53/EC regarding the use of lead and other dangerous substances in electrical components and modules for automotive applications



## 2.10 CPS - Chassis Position Sensor

CPS is the angular sensor developed by Continental. Combining the experience and know-how of the previous ground clearance and pedal angle sensors, this functional sensor has been obtained with optimized cost.

The Hall IC angle sensor allows to obtain a complete 360 ° measurement range. The range is programmable according to customer needs, e.g. 4x90 °. The signal can be analog, PWM or SENT, with PSI5 on specific request, as single or redundant output.

### Application

The CPS is mainly used to measure the movement of the wheels / axle in relation to the chassis control system, for the control of the active suspension and the leveling of the headlamps. Other Applications of the CPS include the measurement of the pedal angle for brake, clutch and e-gas. An acceleration sensor can be integrated in the same housing.

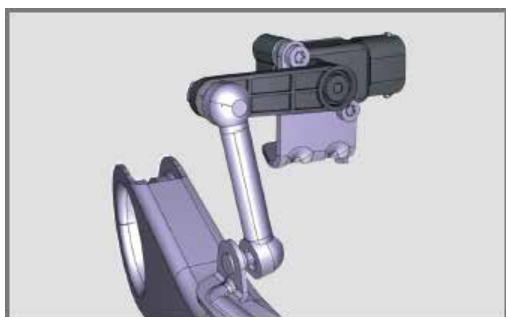

Exemplary illustration of installation on a vehicle

Available only for OE applications on request

### Main features

- Hall principle (angular)
- Measuring range: Standard 4x90° Customer specific 360° programmable
- Resolution 12bit/90°
- Programmable offset
- Special redundancy or integration option
- 2 thread bushing
- Qualified for automotive system

### Chassis Control Applications

- Suspension
- Active damping control
- Headlamp levelling system
- Advanced front lighting systems

### Other possible automotive applications

Pedal angle Sensor, integration of acceleration sensor

## Technical specifications

Electrical characteristics:	
Voltage Supply	5V typ. (min. 4.75V, max. 5.25V)
Current consumption-	15 mA
Operating temperature	-40°C to +125°C
Max. overvoltage	18V.
Reverse polarity.	16V
Characteristics:	
Type of sensor	CPS 1B
Measurement range	Programmable
Offset	Programmable
Sensibility	Programmable
Output signal	0.5V - 4.5V for analogue
Offset error (total error)	+/- 2%
Mechanical Characteristics:	
Housing material	PBT +30% GF
Weight	35g
Protection class	IP6K9K (with connector inserted)
Mounting method	Fixed with 2 x M5 screws
Connector type	TYCO MQS 6 pin, terminal SN, 0,63,,
Lenght (with connector)	64.0 mm
Height	35.5 mm
Width	34.3 mm
Distance fixtures	32.0 mm

## Dimensions

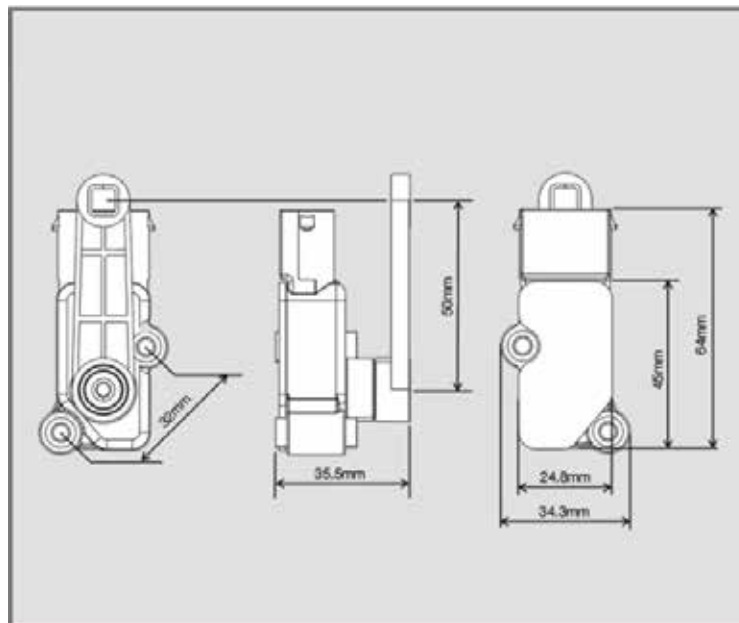

### Directive 2000 / 53 / EC

The CPS sensor complies with the requirements of DIRECTIVE 2000/53 / EC regarding the use of lead and other dangerous substances in electrical components and modules for automotive applications



## 2.11 Chassis Acceleration Sensor - BSZ04 serie

BSZ04 is a single-axis low-g acceleration sensor with an analogue output developed for chassis control applications. It represents the second generation of a family of chassis acceleration sensors, introduced more than a decade ago and of which over six million pieces are currently in use. The heart of the BSZ04 sensor is the SCA6X0 micro-mechanical sensor element from VTI, a robust capacitive acceleration sensor with excellent static and dynamic performance. The sensor element is completed by two ASICs that provide the necessary signal processing and protection circuit.

The BSZ04 sensor is equipped with an integrated MQS connector.

### Application

BSZ04 is mainly used for the detection of horizontal and vertical accelerations for chassis control. Various measuring ranges from  $\pm 0.5$  g to  $\pm 15.0$  g allow the detection of both the movements of the vehicle body and the acceleration of the axles and wheels.

Other automotive applications include start / stop and hill start assistance (inclination measurement) engine vibration management and power gates control.

Thanks to their broad applicability, proven performance and excellent quality, BSZ04 sensors are the worldwide solution for chassis control systems.

### Main features

- Measuring range  $\pm 0.5$ g up to  $\pm 15.0$ g
- Measurement directions in x-, y- or z. axis
- High sensibility 0.13V/g up to 4.0V/g
- Overload protection (1000g, 1ms)
- Overvoltage protection up to 16V
- Reverse polarity protection up to 14.5V
- Temperature range from  $-40^{\circ}\text{C}$  to  $+125^{\circ}\text{C}$
- Qualified for automotive safety system
- High quality,  $<10$ ppm 0 km defect
- Experience form over 10 million chassis sensors

### Chassis control Applications

- Vertical acceleration
- Lateral/longitudinal body acceleration
- Wheel/axle acceleration

Available only for OE applications on request

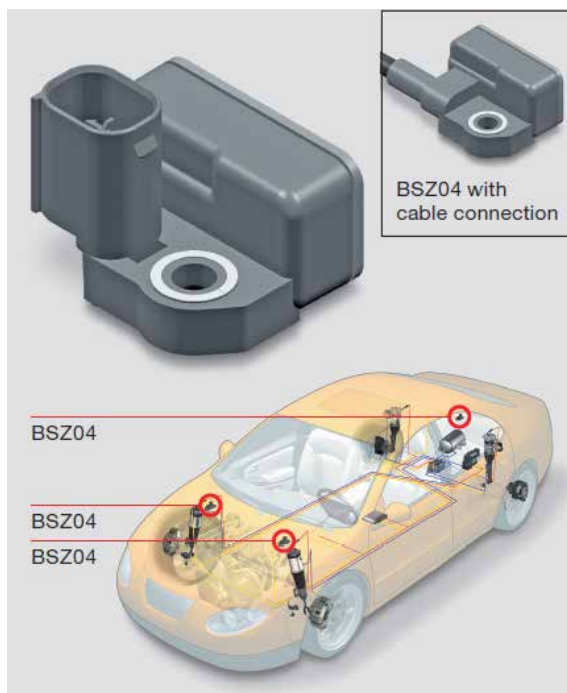

### Other automotive applications

- Inclination measurement (start/stop and hill start)
- Engine vibration management
- Power gate and top lift position control



## 2.12 UniNO<sub>x</sub> Sensor

Our innovative sensor is helping to meet the global demand for increased performance and reduced exhaust emissions. UniNO<sub>x</sub> sensor technology is an invaluable aid for car manufacturers who are faced with increasingly stringent emissions legislation and the simultaneous need to reduce fuel consumption. This sensor is the product of the collaborative development between Continental and NGK insulators, which exploited the specific skills of the two companies in the fields of electronics (Continental) and sensor technology (NGK).

### Concept

The UniNO<sub>x</sub> sensor comprises a ceramic multi-layered zirconium element in a metal housing connected to an ECU by a 600 mm long cable.

As in a linear broadband lambda sensor, electrochemical pumps are used to establish the oxygen concentration in the sensitive element. The concentration of NO<sub>x</sub> in the exhaust gas is proportional to the pump current in the sensor element.

Based on the measured physical values, the ECU calculates three output signals (NO<sub>x</sub>, binary, linear). These signals are then transmitted to the engine ECU on the CAN bus.

### Benefits

- Modular, stand alone NO<sub>x</sub>
  - It communicate via standard CAN bus interface.
  - No restrictions with suppliers of catalytic converters, electronic control units and engine management systems.
  - Heating element control and driver stages integrated into ECU
  - Self-diagnostics for short circuit and cable break
- High precision, calibrated UniNO<sub>x</sub> sensor
  - Exceptional expertise combined in electronics and sensor technology through collaboration between NGK Insulators and Continental.
  - Over 20 years experience in sensor technology.
  - Designed by experts in sensor calibration and control techniques.
- Widely produced in series
  - Used in petrol engines since 2001.
  - Used in diesel engines since 2005.



## Applications

Manufacturers looking to meet current and future emission standards and associated legislation, such as Euro 5, 6, V, VI, US07 and US10, can rely on the UniNOx sensor to support them in the implementation of various types of treatment systems. exhaust gases both petrol and diesel engines

### Petrol engines for cars

UniNOx sensors are used to control the regeneration cycle of NOx (NSC) storage catalysts in combination with lean combustion engines (GDI / FSI / HPDI).

### Diesel engines

- Cars and vans
  - Monitoring of DEF measurement in SCR systems.
  - Control of the NSC regeneration cycle.
  - It can be used for OBD with all exhaust gas treatment systems.
- Medium and heavy trucks
  - Monitoring of the measurement of DEF in SCR systems
  - It can be used for OBD with all exhaust gas treatment systems.



## General Specifications

Measurement	ZrO <sub>2</sub> -based multi-layer sensor with integrated heater and 3 oxygen pumps
Tre segnali di uscita	NO <sub>x</sub> , binary λ, linear λ and O <sub>2</sub> concentration
Electrical systems	12 V or 24 V
Data link	SAE J-1939
Auto diagnostics	Short circuit and cable break
Operating temperature (gas)	100 – 800 °C
Measuring range	NO <sub>x</sub> : 0 – 1,500 ppm λ: 0.75

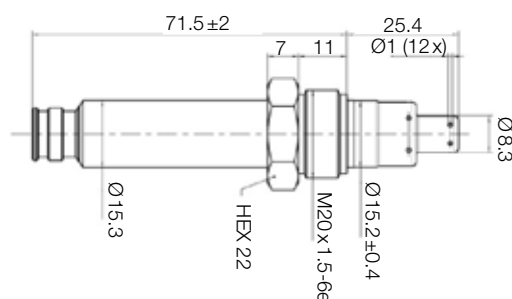
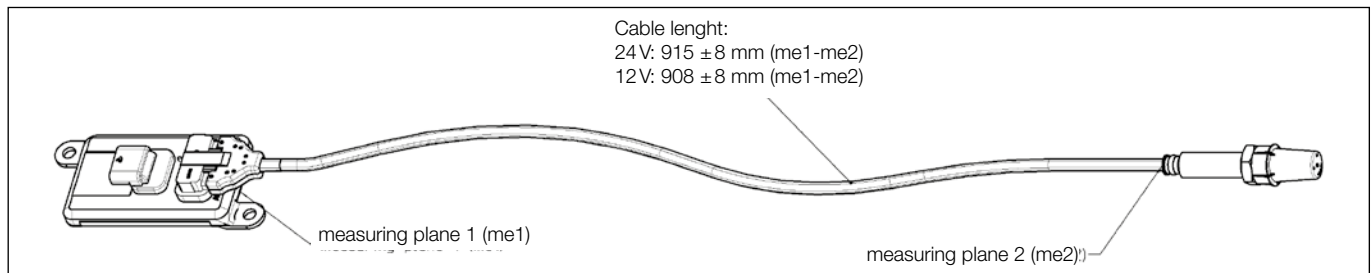

## Order Part numbers

	12V	24V
UNINOX Generation 2.1	5WK96622	A2C53255626
UNINOX Generation 2.5	5WK96713	5WK96714
UNINOX Generation 2.8	5WK96755	5WK96756
Connector counterpart 12/24V (10 pcs packaged)	A2C59512190	



## 2.13 ADAS Systems - RADAR Sensors

Stress and unexpected events accompany modern mobility. Multiple risks require rapid and precise action without ever losing sight of the traffic situation. Advanced driver assistance tools help the driver keep the situation under control at all times. They offer driving comfort and ensure that the driver is relaxed when he reaches his destination and act as electronic copilots, offer pure driving comfort, make driving safer and stress-free. Advanced and intelligent driver assistance systems do not get tired, react quickly and reliably when traffic situations become acute. A pleasant feeling of not being alone. Just delegate strenuous work to your electronic co-pilot, to have more fun in complete safety.

### SRL 1X - Short range lidar

The short-range Lidar can measure the distance and speed of multiple objects.

#### Performance

- SRL1 measures the distance from reflectorless objects using the flight time technique with a very high repetition rate
- A special feature of the device is the measurement of the distance and speed of multiple objects in three independent measurement channels in a close range up to 10 m
- Using infrared laser technology and the development and mass production of automotive supplies, the costs are low.
- Real-time scanning (refresh 1/100 sec)
- Distance intervals: 1.00 ... 10 m for natural non-reflective targets
- Resolution in distance measurement: 1mm
- Speed range: +5 ... +160 km/h
- Field of view: 27° horiz. x 12° vert.
- The sensor is compliant with the laser class 1M
- Interfaces: CAN



#### Applications:

- Simple anti-collision protection for vehicles of all types with SRL1C version (three programmable thresholds)
- Industrial and special vehicles (construction machines, forklifts, combine harvesters) Rail mounted vehicles
- Vehicles with autonomous driving (AGVs)
- Speed and distance monitoring

## SRR 20X - Short range radar

The 24 GHz radar technology is used to monitor multiple objects in a wide field of view

### Performances:

- Efficiency of measurements in adverse weather conditions
- High IP Protection class and suitable to withstand all the typical outdoor climatic conditions
- It can be hidden behind a plastic cover (radome)
- Simultaneous measurement of distance, relative velocity and angular relationship between multiple objects
- Real-time scanning (refresh 1/30 sec)
- Distance range: 1.0 ... 50m
- Accuracy in distance measurement: 0.2m for each target
- Speed measurement accuracy: 0.2 km / h for point target
- Speed range: from -146 to +146 km/h
- Field of view 150° orizz. x 12° vert
- Interfaces: CAN
- Dimensions: 155mm x 131.5mm x 26mm (without fixingo)
- Weight: 295g



### Applications:

Collision protection

- With SRR 208-21SSTC it is possible to set up to 8 collision avoidance zones
- For of all kinds of vehicles (earth-moving machines, fork-lift trucks, tractors, combine harvesters, trucks ...)
- Rail vehicles
- Autonomous vehicles (AGVs and UAVs)
- Special transport (module transporters, platform transporters)
- Tower crane (RTG, RMG, STS, bridge cranes, gantry cranes)

Monitoring of objects

- Detection of multiple objects
- Tracing up to 128 individual clusters and 28 objects

## ARS 30X - Long Range Radar

The 77 GHz radar technology used to monitor multiple objects

### Performances:

- Efficiency of measurements in adverse weather conditions
- High IP protection class and suitable for all typical outdoor climatic conditions
- It can be hidden behind a plastic cover (radome)
- Simultaneous measurement of distance, relative velocity and angular relationship between multiple objects
- Real-time scanning (refresh 1/15 sec)
- Distance range: 0.25 ... 60m and 0.25 ... 200m
- Accuracy in distance measurement: 0.13m o 1.5%
- Speed measurement accuracy: 0.5 km/h far / 1.0 km/h near
- Speed range: from -88 to +265 km/h
- Field of View: 56° horiz. x 4.3° vert., adjustable within 10°
- Interfaces: CAN



### Applications:

Collision protection

- With ARS 308-21SSAO it is possible to set up to 8 collision avoidance areas
- Vehicles of all types (construction machines, forklifts, tractors, combined combines ...)
- Rail vehicles
- Autonomous vehicles (AGVs)
- Special transport (module transporters, platform transporters)
- Tower crane (RTG, RMG, STS, bridge cranes, gantry cranes)

Monitoring of objects

- Detection of multiple objects
- Tracciamento di 96 obiettivi individuali e 40 oggetti

## ARS 408X Premium - Long range Radar

The 77 GHz radar technology is used to monitor multiple objects in a very long and wide field of view



### Performance:

- Efficiency of measurements in adverse weather conditions
- High protection class IP and suitable for all typical outdoor climatic conditions
- It can be hidden behind a plastic cover (radome)
- Simultaneous measurement of distance, relative velocity and angular relationship between multiple objects
- Real-time scanning (refresh 1/17 sec)
- Distance range: 0.20 ... 70m and 0.20 ... 250m
- Accuracy in distance measurement: 0.40m far and 0.10m close for each target object
- Accuracy in speed measurement: 0.1 km / h for each target object
- Speed range from -400 to +200 km/h
- Field of View: 120° horiz. and 20° vert. near / 18° horiz. and 14° vert. far
- Interface: CAN
- Voltage Supply: from +8V to +32V DC typ. consumption 0.5A
- Dimensions: 137.3mm x 90.8mm x 30.7mm
- Weight: 320g

### Applications:

Collision protection

- With ARS 408-21SSAO it is possible to set up to 8 anti-collision areas
- Many kinds of vehicles (earth-moving machines, fork-lift trucks, tractors, combine harvesters, trucks ...), Rail vehicles
- Autonomous vehicles (AGVs e UAVs)

### Order Part No.

Product Family	Order Part No.	Description	Quantity/package
SRR 208-2	2910000818900	Evaluation box Radar Sensor SRR 208-2	1
	2910000815800	Short range radar sensor 24GHz SRR 208-2	26
	2910000819000	Short range radar sensor 24GHz SRR 208-2	1
	2910000815900	Cable SRR 2xx, 5m, Voltage Supply and CAN bus	1
	2910000816000	Connector SRR 2xx, 10 pin	1
	2910000816100	DVD with documentation SRR 20x	1
ARS 308-2	2910000819100	Evaluation box Radar Sensor ARS 308-2	1
	2910000814800	Long range radar sensor 77GHz ARS 308-2	14
	2910000819200	Long range radar sensor 77GHz ARS 308-2	1
	2910000814900	Cable ARS 3xx, 5m, Voltage Supply and CAN bus	1
	2910000815000	Connector ARS 3xx, 8 pin	1
	2910000815100	DVD with documentation ARS 30x	1
ARS 408-21	2910000819300	Evaluation box Radar Sensor ARS 408-21	1
	2910000815300	Premium Long range radar sensor 77GHz ARS 408-21	22
	2910000819400	Premium Long range radar sensor 77GHz ARS 408-21	1
	2910000815400	Cable ARS 408, 5m, Voltage Supply and CAN bus	1
	2910000815500	Connector ARS 408, 8 pin	1
	2910000815600	DVD with documentation ARS 408-21 and accessories	1

Notice: the information provided contains only general descriptions or performance characteristics, which do not always apply as described for actual use or which may change as a result of further product development. This information represents only a technical description of the product. This information is not intended as a guarantee for a particular quality or a particular duration. The obligation to provide the respective characteristics exists only if expressly agreed in the terms of the contract. We reserve the right to make changes and technical modifications without notice.



## 3. Fuel and Water Level Senders

Fuel level measurement for commercial and special vehicles. Inaccuracies in the fuel level indication can lead to vehicle stoppage - Reliability and accuracy are the key features that any fuel level measurement system must necessarily have.

### **Innovative solutions**

Our sensors are specifically designed to meet a wide range of applications and withstand often extremely difficult operating conditions. We have been active in this field for over 30 years and thanks to the innovations introduced as the Magnetic Passive Position Sensor (MAPP), we have achieved an enormous improvement in the reliability of fuel level measurement systems, even when used with chemically very aggressive fuels.

### **For tanks of all shapes and sizes**

With the range of our products we can offer solutions for all types of tank geometries, mounting flanges (eg EU bayonet flange) and fuel types. Thanks to the modular nature of the systems we are able to support customers who require even small batches of products with customized solutions.

### **Scalable integration**

Our range of solutions includes both classic models, such as tube or lever transmitters, non-contact and low-wear sensors, as well as sensors based on Thick-film network (DSN) technology. Depending on the requirements of the tank or vehicle manufacturer we can provide simple and robust sensors as well as complex solutions that include fuel supply and return lines for injection systems, or auxil-

iary fuel heating and tank ventilation systems; all integrated into the flange. All systems are built for long service life, regardless of their design and have proven to support many years of continuous use, as demonstrated in mass production applications.

### **Thick-film network technology**

Thick-film network technology has become a consolidated standard for modern level sensors due to its reliability, measurement accuracy and the possibility of adapting the characteristic resistance curve to irregular tank geometries.

We offer several models of lever sensors that use this technology, all designed for specific standards along the required environments. The standard model provides a double contact AgNi20 and is validated for one million cycles.

A “three-finger” system with two series of three contacts is also available, with units designed for one million cycles (material: Hera 649) or two million cycles (AuNi5), depending on the composition of the material.

### A sensor, several tanks

Our range also includes an economical solution suitable for a wide range of tank forms of a sensor. The ALAS I sensor (adjustable lever arm sensor) can be adjusted to measure depth of the fuel tank between 100 and 400 mm. Vehicle manufacturers and power system specialists now have the option of using only one type of sensor to equip an entire range of tanks of different depths. This solution is particularly advantageous for the production of small volumes characteristic of special vehicles.



Plastic arm sensor (DSN technology)



Plastic arm sensor (MAPPA technology)



ALAS I adjustable arm level sensor



Tubular level sensor in aluminum



Steel Tubular level sensor

### Non-contact measuring elements for use with aggressive fuels.

Sensors made with conventional technologies are suitable to meet the service life required for petrol and diesel applications, but this is not enough with new fuels such as rapeseed methyl ester (RME rapeseed methyl ester - biodiesel). Aggressive substances have been found which accelerate the wear of the contact surfaces of thick film sensors, even if they are made of high quality material. Therefore the most concrete way to guarantee continuous and trouble-free efficiency is the use of sensors with contactless meters.

Our products, which satisfy this requirement, use MAPPS technology. The MAPPS element uses flexible contact levers acting on a contact strip moved by a magnet on the sensor lever.

With this patented technology, the real sensitive element is hermetically sealed and never comes into contact with fuel.

The measurements are generated by the contact of the metal levers, moved by the magnetic force of the lever, on a contact strip which in turn causes a variation of the electrical resistance, thus generating the measurement value.



The hermetically sealed MAPPS element is only 4 cm long

**MAPPS technology:** the magnet on the lever arm attracts the flexible contact flaps on a contact strip, thus creating a characteristic resistance signal.



### 3.1 Fuel and Water Level Senders, Tubular type

3.1.1 Tubular Fuel Level senders, Metal, Standard

3.1.2 Tubular Fuel and Water Level senders, Stainless steel

3.1.3 Tubular Fuel level Sender, Plastic

### 3.1.1 Tubular Fuel Level senders, Metal, Standard

FLANGE BOLT HOLE CIRCLE Ø 54 MM

#### Dimensions [mm]

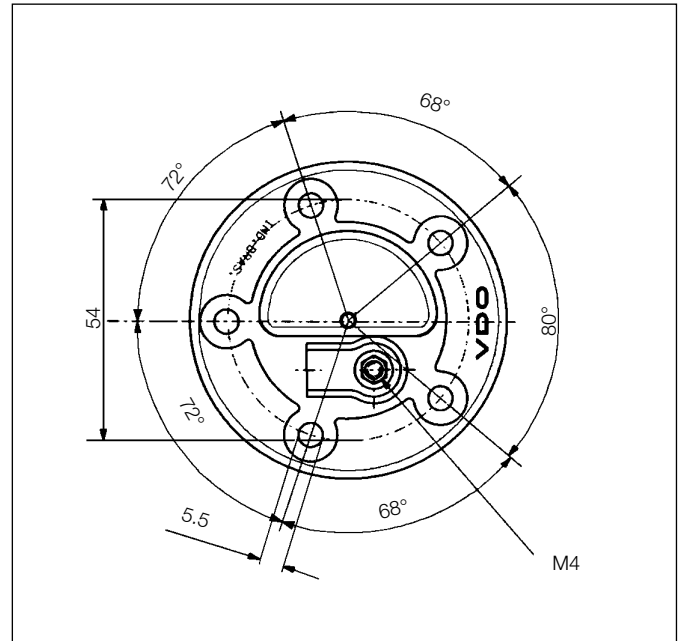
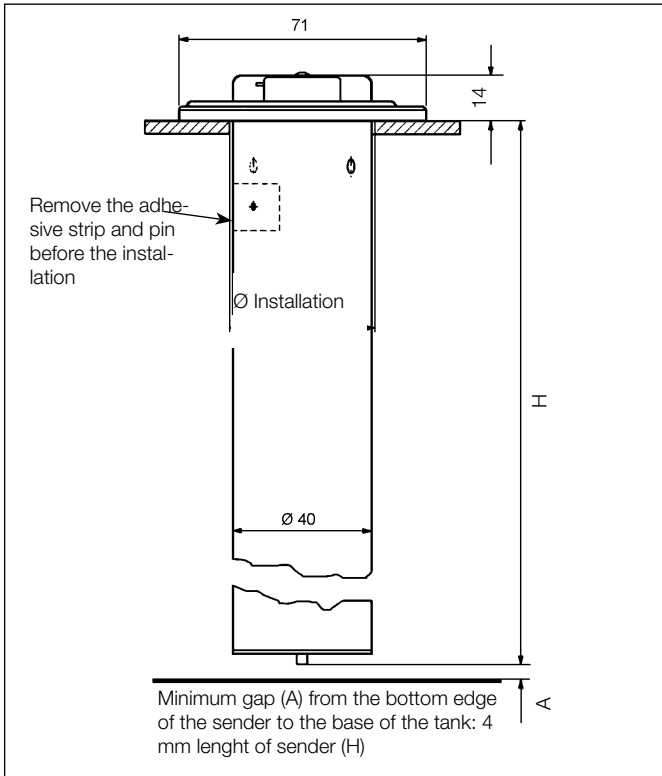

The electrical connection can be made as follows using the 2 6.3 x 0.8 mm blade terminals provided:

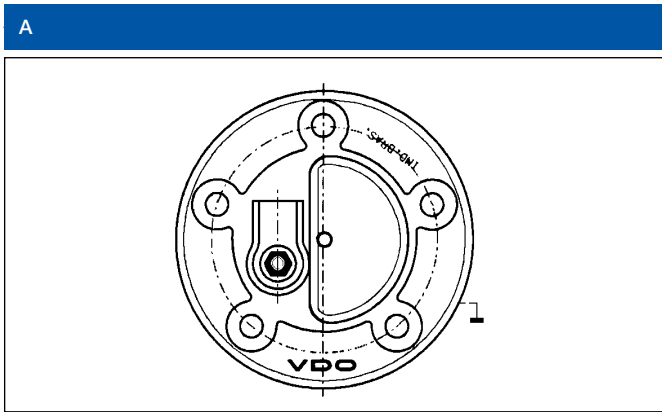

M4 FOR OUTPUT SIGNAL, NO GROUND CONNECTION

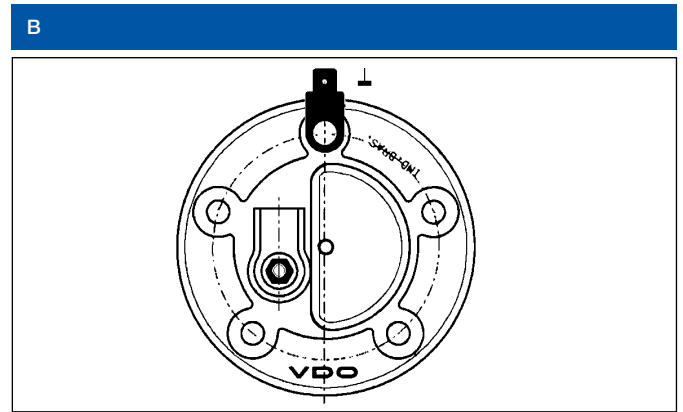

M4 FOR OUTPUT SIGNAL, BLADE TERMINAL FOR GROUND

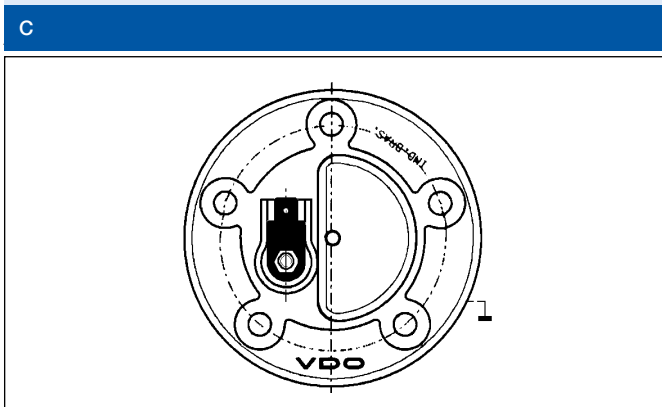

BLADE TERMINAL FOR OUTPUT, NO GROUND CONNECTION

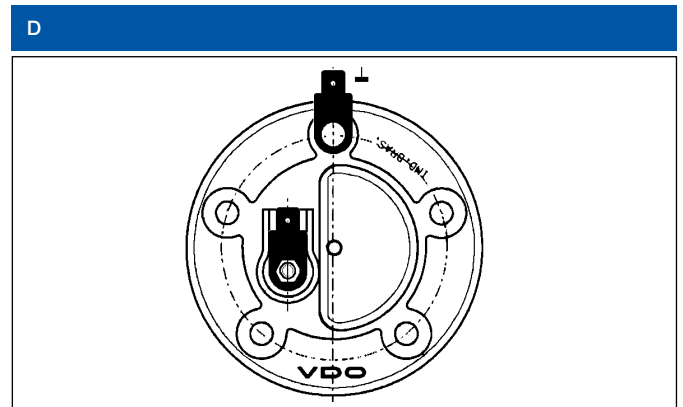

BLADE TERMINALS FOR OUTPUT AND GROUND



Package	Order Part No.	H [mm]	R Full [ohm], tolerance	R empty [ohm], tolerance	Support spring	Electrical connection**	Ground connection
Bulk 40 pcs.	224-011-000-150X	150	4,5 ± 1,5	69,0 ± 2,5	No	1/2	Optional
Single	224-011-000-150G	150	4,5 ± 1,5	69,0 ± 2,5	No	1/2	Optional
Bulk 40 pcs.	224-011-000-160X	160	4,5 ± 1,5	74,0 ± 2,5	No	1/2	Optional
Single	224-011-000-160G	160	4,5 ± 1,5	74,0 ± 2,5	No	1/2	Optional
Bulk 40 pcs.	224-011-000-170X	170	4,5 ± 1,5	79,0 ± 2,5	No	1/2	Optional
Single	224-011-000-170G	170	4,5 ± 1,5	79,0 ± 2,5	No	1/2	Optional
Bulk 40 pcs.	224-011-000-180X*	180	3,0 ± 1,5	64,0 ± 2,5	No	1/2	Optional
Single	224-011-000-180G*	180	3,0 ± 1,5	64,0 ± 2,5	No	1/2	Optional
Bulk 40 pcs.	224-011-000-190X*	190	3,0 ± 1,5	68,0 ± 2,5	No	1/2	Optional
Single	224-011-000-190G*	190	3,0 ± 1,5	68,0 ± 2,5	No	1/2	Optional
Bulk 40 pcs.	224-011-000-200X	200	2,5 ± 1,5	68,0 ± 2,5	No	1/2	Optional
Single	224-011-000-200G	200	2,5 ± 1,5	68,0 ± 2,5	No	1/2	Optional
Bulk 40 pcs.	224-011-000-210X*	210	3,0 ± 1,5	76,0 ± 2,5	No	1/2	Optional
Single	224-011-000-210G*	210	3,0 ± 1,5	76,0 ± 2,5	No	1/2	Optional
Bulk 40 pcs.	224-011-000-220X	220	3,0 ± 1,5	80,0 ± 2,5	No	1/2	Optional
Single	224-011-000-220G	220	3,0 ± 1,5	80,0 ± 2,5	No	1/2	Optional
Bulk 40 pcs.	224-011-020-221X	221	3,0 ± 1,0	78,8 ± 2,3	No	2	No
Single	224-011-020-221G	221	3,0 ± 1,0	78,8 ± 2,3	No	2	No
Bulk 40 pcs.	224-011-000-230X	230	2,5 ± 1,5	84,0 ± 2,5	No	1/2	Optional
Single	224-011-000-230G	230	2,5 ± 1,5	84,0 ± 2,5	No	1/2	Optional
Bulk 40 pcs.	224-011-000-240X	240	2,5 ± 1,5	65,5 ± 2,5	No	1/2	Optional
Single	224-011-000-240G	240	2,5 ± 1,5	65,5 ± 2,5	No	1/2	Optional
Bulk 40 pcs.	224-011-000-250X	250	2,5 ± 1,5	72,0 ± 2,5	No	1/2	Optional
Single	224-011-000-250G	250	2,5 ± 1,5	72,0 ± 2,5	No	1/2	Optional
Bulk 20 pcs.	224-011-010-251X	251	2,0 ± 1,0	62,5 ± 2,1	No	3	No
Single	224-011-010-251G	251	2,0 ± 1,0	62,5 ± 2,1	No	3	No
Bulk 40 pcs.	224-011-000-260X	260	2,5 ± 1,5	72,0 ± 2,5	No	1/2	Optional
Single	224-011-000-260G	260	2,5 ± 1,5	72,0 ± 2,5	No	1/2	Optional
Bulk 40 pcs.	224-011-000-270X	270	2,5 ± 1,5	74,5 ± 2,5	No	1/2	Optional
Single	224-011-000-270G	270	2,5 ± 1,5	74,5 ± 2,5	No	1/2	Optional
Bulk 20 pcs.	224-011-020-279X	279	2,0 ± 1,0	70,3 ± 2,3	No	2	No
Single	224-011-020-279G	279	2,0 ± 1,0	70,3 ± 2,3	No	2	No
Bulk 20 pcs.	224-011-000-280X	280	2,5 ± 1,5	75,5 ± 2,5	No	1/2	Optional
Single	224-011-000-280G	280	2,5 ± 1,5	75,5 ± 2,5	No	1/2	Optional
Bulk 20 pcs.	224-011-020-292X	292	2,0 ± 1,0	73,8 ± 2,3	No	2	No
Single	224-011-020-292G	292	2,0 ± 1,0	73,8 ± 2,3	No	2	No
Bulk 20 pcs.	224-011-000-300X	300	2,5 ± 1,5	82,8 ± 2,5	No	1/2	Optional
Single	224-011-000-300G	300	2,5 ± 1,5	82,8 ± 2,5	No	1/2	Optional
Bulk 20 pcs.	224-011-000-310X	310	2,5 ± 1,5	84,0 ± 2,5	No	1/2	Optional
Single	224-011-000-310G	310	2,5 ± 1,5	84,0 ± 2,5	No	1/2	Optional
Bulk 20 pcs.	224-011-010-311X	311	2,5 ± 1,0	81,2 ± 2,7	No	3	No
Single	224-011-010-311G	311	2,5 ± 1,0	81,2 ± 2,7	No	3	No
Bulk 20 pcs.	224-011-000-330X*	330	2,5 ± 1,5	72,0 ± 2,5	No	1/2	Optional
Single	224-011-000-330G*	330	2,5 ± 1,5	72,0 ± 2,5	No	1/2	Optional
Bulk 20 pcs.	224-011-000-340X	340	2,5 ± 1,5	74,0 ± 2,5	No	1/2	Optional
Single	224-011-000-340G	340	2,5 ± 1,5	74,0 ± 2,5	No	1/2	Optional
Bulk 20 pcs.	224-011-010-341X*	341,5	2,0 ± 1,0	89,8 ± 2,5	No	3	No
Single	224-011-010-341G*	341,5	2,0 ± 1,0	89,8 ± 2,5	No	3	No
Bulk 20 pcs.	224-011-010-345X*	345	2,0 ± 1,0	88,7 ± 2,5	No	3	No
Single	224-011-010-345G*	345	2,0 ± 1,0	88,7 ± 2,5	No	3	No
Bulk 20 pcs.	224-011-000-350X	350	2,5 ± 1,5	79,6 ± 2,5	No	1/2	Optional
Single	224-011-000-350G	350	2,5 ± 1,5	79,6 ± 2,5	No	1/2	Optional
Bulk 20 pcs.	224-011-000-360X*	360	2,5 ± 1,5	69,0 ± 2,5	No	1/2	Optional
Single	224-011-000-360G*	360	2,5 ± 1,5	69,0 ± 2,5	No	1/2	Optional
Bulk 20 pcs.	224-011-000-370X	370	2,5 ± 1,5	71,0 ± 2,5	No	1/2	Optional

Package	Order Part No.	H [mm]	R Full [ohm], tolerance	R empty [ohm], tolerance	Support spring	Electrical connection**	Ground connection
Single	224-011-000-370G	370	2,5 ± 1,5	71,0 ± 2,5	No	1/2	Optional
Bulk 20 pcs.	224-011-010-372X	372	1,0 ± 1,0	65,7 ± 2,1	No	3	No
Single	224-011-010-372G	372	1,0 ± 1,0	65,7 ± 2,1	No	3	No
Bulk 20 pcs.	224-011-020-372X	372	1,0 ± 1,0	65,7 ± 2,1	No	2	No
Single	224-011-020-372G	372	1,0 ± 1,0	65,7 ± 2,1	No	2	No
Bulk 20 pcs.	224-011-000-380X	380	2,5 ± 1,5	73,0 ± 2,5	No	1/2	Optional
Single	224-011-000-380G	380	2,5 ± 1,5	73,0 ± 2,5	No	1/2	Optional
Bulk 20 pcs.	224-011-000-390X*	390	2,5 ± 1,5	75,0 ± 2,5	No	1/2	Optional
Single	224-011-000-390G*	390	2,5 ± 1,5	75,0 ± 2,5	No	1/2	Optional
Bulk 20 pcs.	224-011-000-400X	400	2,5 ± 1,5	74,9 ± 2,5	No	1/2	Optional
Single	224-011-000-400G	400	2,5 ± 1,5	74,9 ± 2,5	No	1/2	Optional
Bulk 20 pcs.	224-011-010-404X	404	1,0 ± 1,0	73,3 ± 2,5	No	3	No
Single	224-011-010-404G	404	1,0 ± 1,0	73,3 ± 2,5	No	3	No
Bulk 20 pcs.	224-011-010-433X	433	1,0 ± 1,0	77,3 ± 2,3	No	3	No
Single	224-011-010-433G	433	1,0 ± 1,0	77,3 ± 2,3	No	3	No
Bulk 20 pcs.	224-011-110-442X	442	1,0 ± 1,0	80,6 ± 2,5	Yes	3	No
Single	224-011-110-442G	442	1,0 ± 1,0	80,6 ± 2,5	Yes	3	No
Bulk 20 pcs.	224-011-000-450X	450	2,5 ± 1,5	84,3 ± 2,5	No	1/2	Optional
Single	224-011-000-450G	450	2,5 ± 1,5	84,3 ± 2,5	No	1/2	Optional
Bulk 20 pcs.	224-011-010-463X	463	1,0 ± 1,0	83,0 ± 2,5	No	3	No
Single	224-011-010-463G	463	1,0 ± 1,0	83,0 ± 2,5	No	3	No
Bulk 20 pcs.	224-011-010-478X	478	1,0 ± 1,0	85,9 ± 2,5	No	3	No
Single	224-011-010-478G	478	1,0 ± 1,0	85,9 ± 2,5	No	3	No
Bulk 20 pcs.	224-011-110-498X	498	1,0 ± 1,0	61,4 ± 2,1	Yes	3	No
Single	224-011-110-498G	498	1,0 ± 1,0	61,4 ± 2,1	Yes	3	No
Bulk 20 pcs.	224-011-000-500X	500	2,5 ± 1,5	75,4 ± 2,5	No	1/2	Optional
Single	224-011-000-500G	500	2,5 ± 1,5	75,4 ± 2,5	No	1/2	Optional
Bulk 20 pcs.	224-011-022-521X*	521	1,0 ± 1,0	94,1 ± 2,7	No	2	Yes
Single	224-011-022-521G*	521	1,0 ± 1,0	94,1 ± 2,7	No	2	Yes
Bulk 20 pcs.	224-011-000-550X	550	2,5 ± 1,5	77,6 ± 2,5	No	1/2	Optional
Single	224-011-000-550G	550	2,5 ± 1,5	77,6 ± 2,5	No	1/2	Optional
Bulk 25 pcs.	224-011-010-590X	590	1,0 ± 1,0	73,3 ± 2,3	No	3	No
Single	224-011-010-590G	590	1,0 ± 1,0	73,3 ± 2,3	No	3	No
Bulk 25 pcs.	224-011-022-590X	590	1,0 ± 1,0	73,3 ± 2,3	No	2	Yes
Single	224-011-022-590G	590	1,0 ± 1,0	73,3 ± 2,3	No	2	Yes
Bulk 25 pcs.	224-011-120-596X	596	1,0 ± 1,0	74,1 ± 2,3	Yes	2	No
Single	224-011-120-596G	596	1,0 ± 1,0	74,1 ± 2,3	Yes	2	No
Bulk 25 pcs.	224-011-000-600X	600	2,5 ± 1,5	85,3 ± 2,5	No	1/2	Optional
Single	224-011-000-600G	600	2,5 ± 1,5	85,3 ± 2,5	No	1/2	Optional
Bulk 15 pcs.	224-011-010-613X*	613,5	1,0 ± 1,0	76,3 ± 2,3	No	3	No
Single	224-011-010-613G*	613,5	1,0 ± 1,0	76,3 ± 2,3	No	3	No
Bulk 15 pcs.	224-011-110-634X	634	1,0 ± 1,0	79,0 ± 2,3	Yes	3	No
Single	224-011-110-634G	634	1,0 ± 1,0	79,0 ± 2,3	Yes	3	No
Bulk 15 pcs.	224-011-000-650X*	650	2,5 ± 1,5	82,2 ± 2,5	No	1/2	Optional
Single	224-011-000-650G*	650	2,5 ± 1,5	82,2 ± 2,5	No	1/2	Optional
Bulk 15 pcs.	224-011-110-650X	650	1,0 ± 1,0	82,2 ± 2,5	Yes	3	No
Single	224-011-110-650G	650	1,0 ± 1,0	82,2 ± 2,5	Yes	3	No
Bulk 15 pcs.	224-011-110-664X	664	1,0 ± 1,0	84,0 ± 2,5	Yes	3	No
Single	224-011-110-664G	664	1,0 ± 1,0	84,0 ± 2,5	Yes	3	No
Bulk 15 pcs.	224-011-010-691X	691,5	1,0 ± 1,0	66,5 ± 2,1	No	3	No
Single	224-011-010-691G	691,5	1,0 ± 1,0	66,5 ± 2,1	No	3	No
Bulk 15 pcs.	224-011-000-700X	700	2,0 ± 1,5	81,6 ± 2,5	No	1/2	Optional

Package	Order Part No.	H [mm]	R Full [ohm], tolerance	R empty [ohm], tolerance	Support spring	Electrical connection**	Ground connection
Single	224-011-000-700G	700	2,0 ± 1,5	81,6 ± 2,5	No	1/2	Optional
Bulk 15 pcs.	224-011-000-750X*	750	2,0 ± 1,5	82,0 ± 2,5	No	1/2	Optional
Single	224-011-000-750G*	750	2,0 ± 1,5	82,0 ± 2,5	No	1/2	Optional
Bulk 15 pcs.	224-011-010-786X	786	1,0 ± 1,0	76,0 ± 2,3	No	3	No
Single	224-011-010-786G	786	1,0 ± 1,0	76,0 ± 2,3	No	3	No
Bulk 15 pcs.	224-011-000-800X	800	2,0 ± 1,5	68,5 ± 2,5	No	1/2	Optional
Single	224-011-000-800G	800	2,0 ± 1,5	68,5 ± 2,5	No	1/2	Optional
Bulk 15 pcs.	224-011-110-810X	810	1,0 ± 1,0	70,6 ± 2,5	Yes	3	No
Single	224-011-110-810G	810	1,0 ± 1,0	70,6 ± 2,5	Yes	3	No

\*On request - limited availability

\*\* 1: connection nut, 2: blade terminals, 3: hexagonal nuts

ACCESSORIES	
Order Part No.	Descrizione
890-225-012	Gasket (Cork Rubber) Ø 66.5 x 4.5 mm
2-250-234	Gasket (Cork) Ø 66.5 x 4.5 mm
2-251-243	Gasket (Rubber) Ø 65.0 x 2.7 mm
N06-016-230	Gasket (Rubber) Ø 65.6 x 3.0 mm
2-250-264-1241	Flange, zinc plated, passivated blue
N05-801-434	Kit screwed flange for tube immersion

### 3.1.2 Tubular Fuel and Water Level senders, Stainless steel

Tubular sensors, manufactured in stainless steel. They are completely watertight and suitable for measuring the level of different liquids, from water to fuel

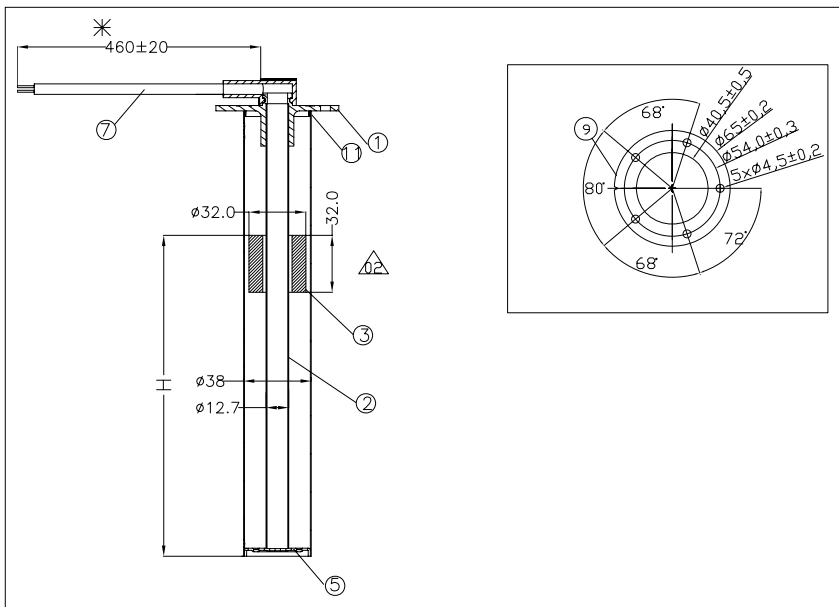

Tubular sensor in stainless steel

TECHNICAL FEATURES	
Available lengths:	from 150 to 1000 mm (other lengths on request)
Voltage:	6V - 24V
Operating temperature:	from -30°C to +70°C
Flange for fixing:	5 holes Ø 54mm
Material:	Stainless steel AISI316

### European Standard

Order Part No.	L	Ω
	[mm]	[Value]
ES-224-011-0150	150	0-180
ES-224-011-0160	160	0-180
ES-224-011-0170	170	0-180
ES-224-011-0180	180	0-180
ES-224-011-0200	200	0-180
ES-224-011-0220	220	0-180
ES-224-011-0230	230	0-180
ES-224-011-0250	250	0-180
ES-224-011-0280	280	0-180
ES-224-011-0300	300	0-180
ES-224-011-0350	350	0-180
ES-224-011-0370	370	0-180
ES-224-011-0400	400	0-180
ES-224-011-0450	450	0-180
ES-224-011-0500	500	0-180
ES-224-011-0550	550	0-180
ES-224-011-0600	600	0-180
ES-224-011-0650	650	0-180
ES-224-011-0700	700	0-180
ES-224-011-0750	750	0-180
ES-224-011-0800	800	0-180
ES-224-011-0850	850	0-180
ES-224-011-0900	900	0-180
ES-224-011-1000	1000	0-180

### USA Standard

Order Part No.	L	Ω
	[mm]	[Value]
ES-224-012-0150	150	240-33
ES-224-012-0160	160	240-33
ES-224-012-0170	170	240-33
ES-224-012-0200	200	240-33
ES-224-012-0230	230	240-33
ES-224-012-0250	250	240-33
ES-224-012-0280	280	240-33
ES-224-012-0300	300	240-33
ES-224-012-0330	330	240-33
ES-224-012-0350	350	240-33
ES-224-012-0400	400	240-33
ES-224-012-0430	430	240-33
ES-224-012-0450	450	240-33
ES-224-012-0500	500	240-33
ES-224-012-0550	550	240-33
ES-224-012-0600	600	240-33
ES-224-012-0900	900	240-33
ES-224-012-0980	980	240-33

### 3.1.3 Tubular Fuel level Sender, Plastic

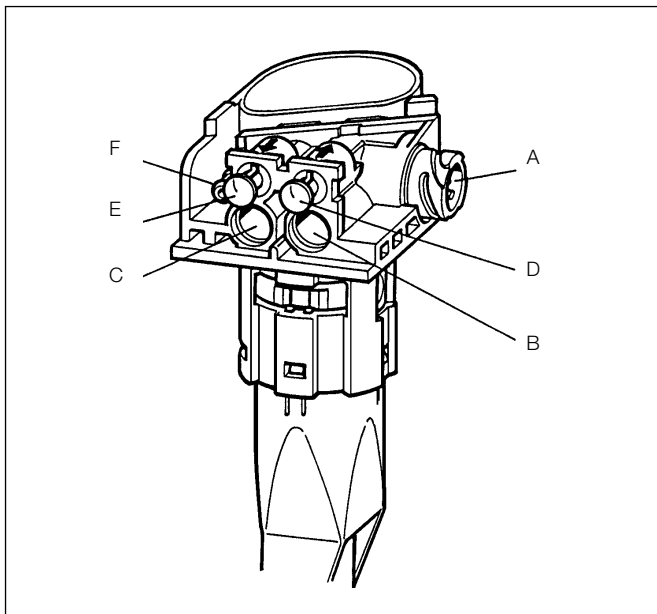

#### Technical features

Voltage	6–24 V (Insulated ground)	
Resistance	3 $\Omega$ (empty) a 180 $\Omega$ (full)	
Current	Bulk 20 pcs. mA a 120 mA	
Operating temperature	from -30 °C to +70 °C	
Air inlet and outlet valves	Positive pressure up to 200 mbar which corresponds to a flow less than Bulk 25 pcs. g/min diesel. Positive pressure greater than 300 mbar corresponds to a larger flow of Bulk 25 pcs. g/min diesel Negative pressure of 10 - Bulk 20 pcs. mbar corresponds to a flow greater than 1.75 l/h of diesel oil	
Service life	1 million full / empty cycles in super unleaded petrol	
Vibration test	Bulk 20 pcs. a 50 Hz 50 a 1,000 Hz 8 h / axle	PSD = 0.03 g <sup>2</sup> /Hz PSD = -6 dB/oct
Material	Flange, sender body, float: POM-C Float lever arm: X12CrNi 177k Tube: PA11 or PA12	

#### Connections

A	Bayonet connector, DIN 72585 (A1-2.1RG/K1)
B	Outlet
C	Inlet
D	External heater outlet or pressure equalization with another tank
E	External heater inlet
F	Outlet air valve

## Dimensions [mm]

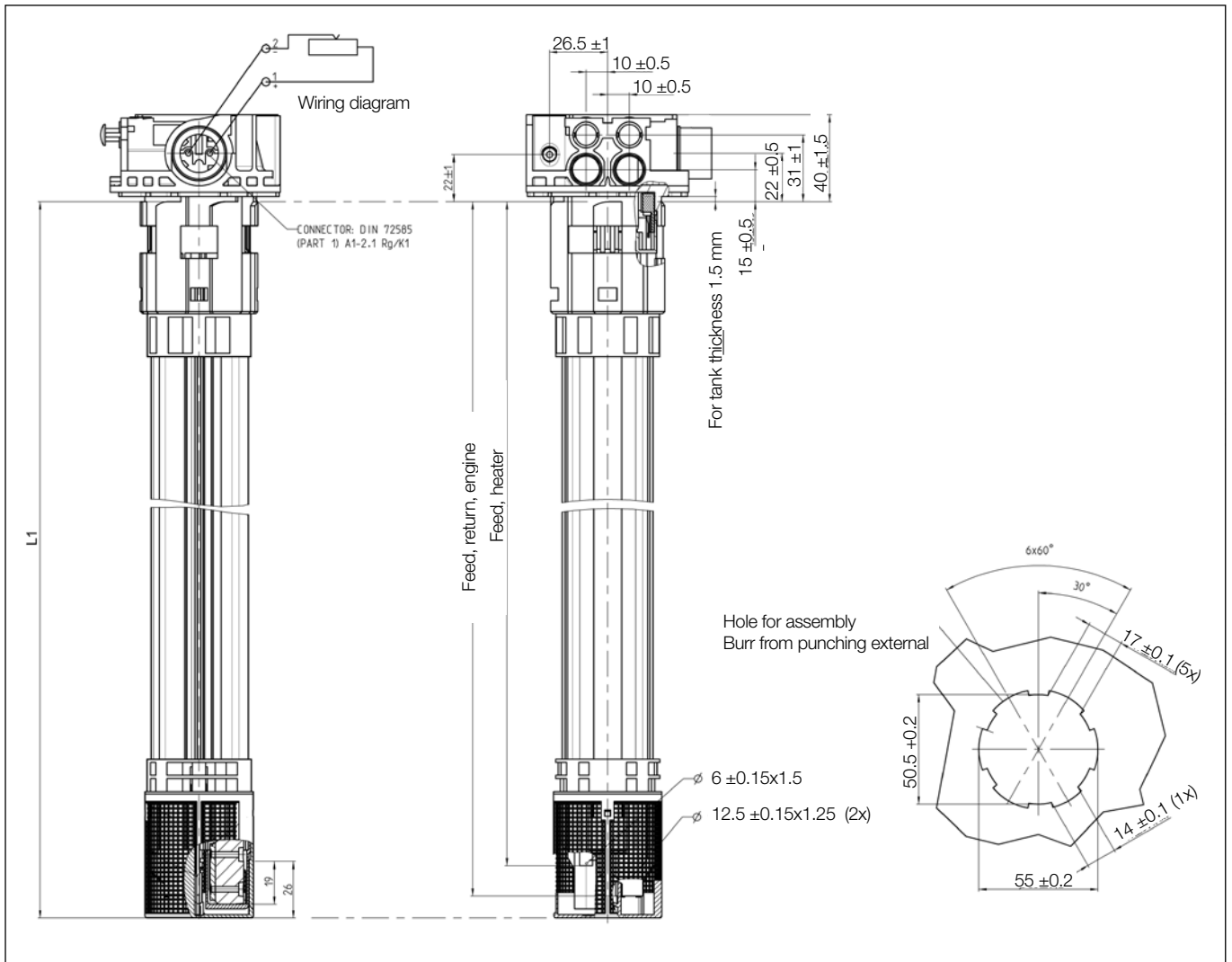

Order Part No.	Lenght L1	Lenght tube Inlet L2	Lenght heating tube
	[mm]	[mm]	[mm]
A2C59510128	455 ± 2	446 <sup>+2.5</sup> <sub>-3.5</sub>	432 <sup>+2.5</sup> <sub>-3.5</sub>
A2C59510129	544 ± 2	535 <sup>+2.5</sup> <sub>-3.5</sub>	519 <sup>+2.5</sup> <sub>-3.5</sub>
A2C59510130	672 ± 2	663 <sup>+2.5</sup> <sub>-3.5</sub>	654 <sup>+2.5</sup> <sub>-3.5</sub>

Full: 180 Ω ± 3.7 Ω, empty: 3 Ω ± 1.05 Ω

Order Part No.	Accessories	Units per Packing
89-356-017	O-ring (Gasket)	100
X11-221-001-002	Inlet/Outlet connectors	Bulk 20 pcs.
X11-221-001-003	Locking mechanism Inlet/Outlet of external heater	10
X11-221-001-004	External heater connector	Bulk 20 pcs.
Standard	Bayonet connector DIN 72585 A1-2.1 SN/K1	Non included



## 3.2 Fuel level Senders, Lever-Arm type

3.2.1 Lever-arm Fuel Level sender, Plastic

3.2.2 Adjustable Lever-arm Fuel Level Sender, Standard/ALAS I

### 3.2.1 Lever-arm Fuel Level sender, Plastic

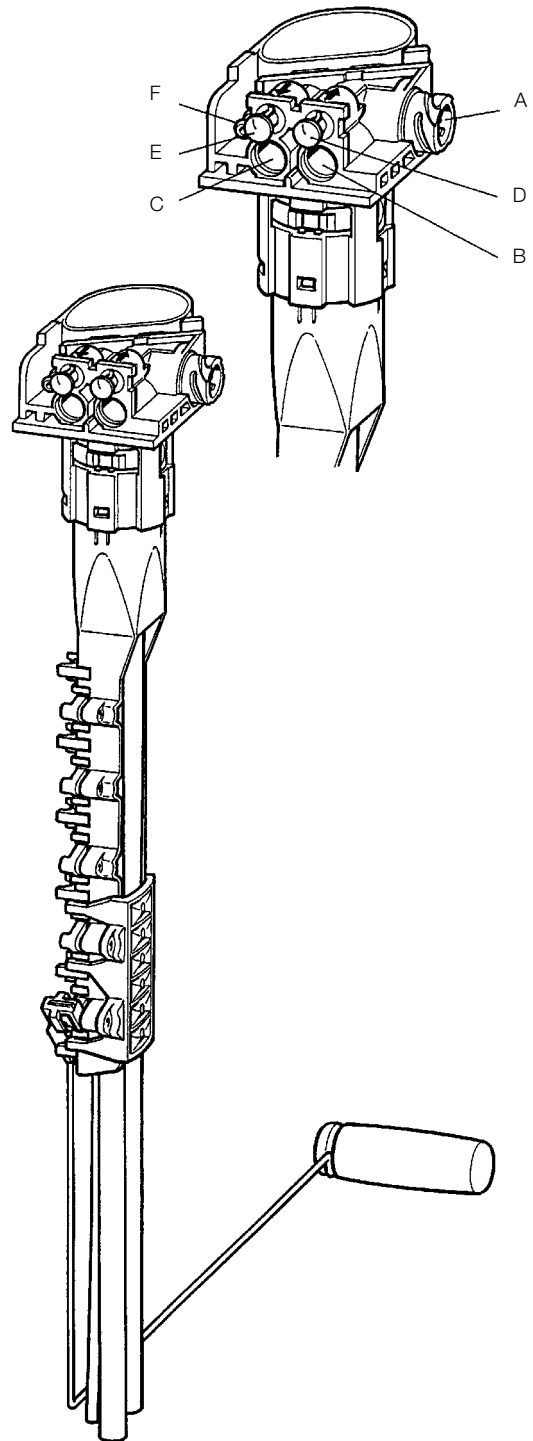

Technical features	
Voltage	6–24 V (Insulated ground)
Resistance	3 Ω (empty) a 180 Ω (full)
Current	Bulk 20 pcs. mA a 120 mA
Operating temperature	from -30 °C to +70 °C
Air inlet and outlet valves	Positive pressure up to 200 mbar which corresponds to a smaller flow of Bulk 25 pcs. g / min diesel. Positive pressure greater than 300 mbar corresponds to a larger flow of Bulk 25 pcs. g / min diesel Negative pressure of 10 - Bulk 20 pcs. mbar corresponds to a flow greater than 1.75 l / h of diesel oil
Service life	1 milione full/empty cycles in diesel fuel
Vibration test	da Bulk 20 pcs. a 50 Hz PSD = 0.03 g <sup>2</sup> /Hz da 50 a 1,000 Hz PSD = -6 dB/oct 8 h / asse
Material	Flange, body, floater: POM-C Floater arm: X10CrNi 18-8 Tube: PA11 or PA12

Connections	
A	Bayonet connector, DIN 72585 (A1-2.1RG/K1)
B	Outlet
C	Inlet
D	External heater outlet or pressure equalization with another tank
E	External heater inlet
F	Outlet air valve



Dimensions [mm]

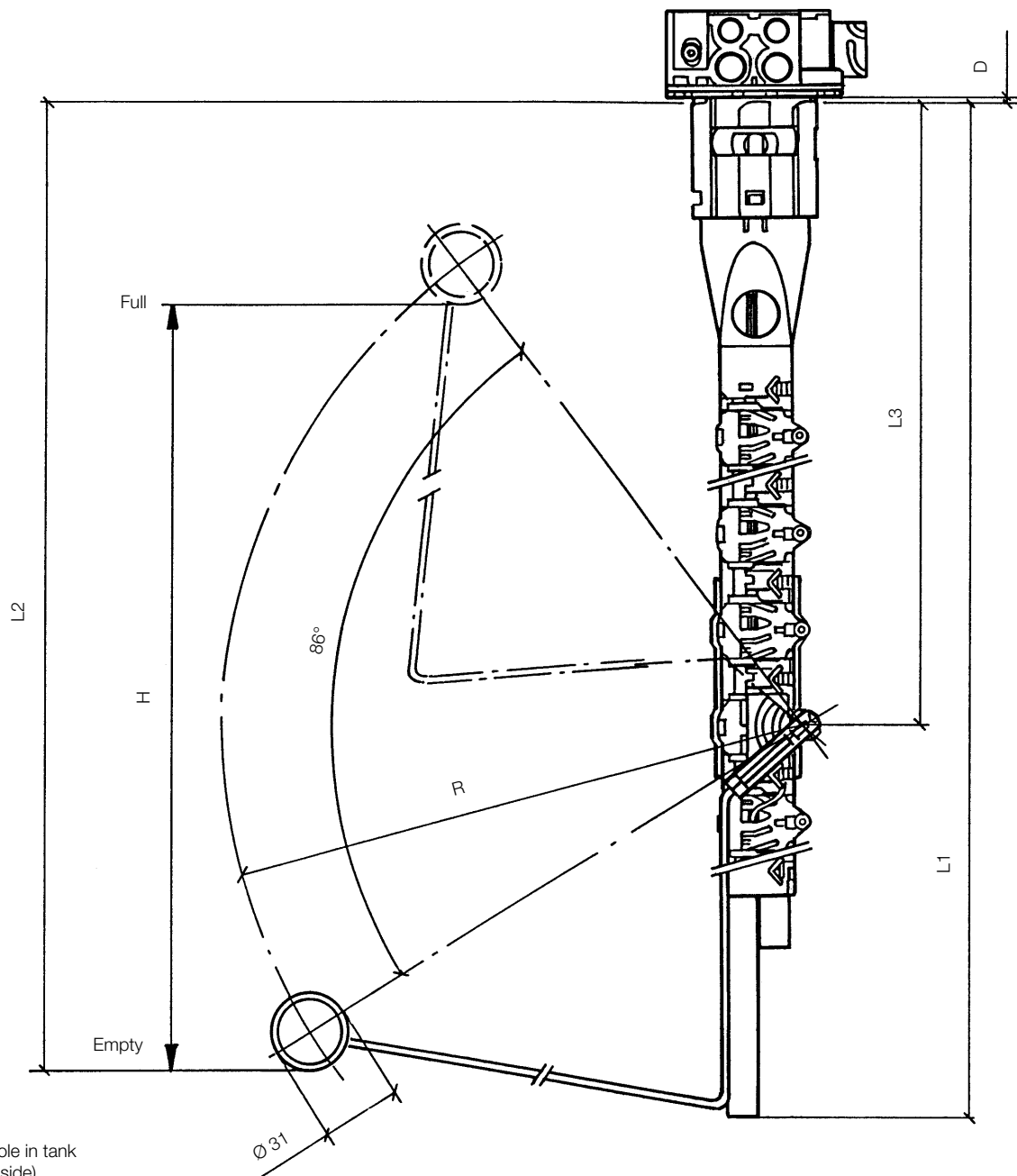

Mounting hole in tank  
(burr on outside)

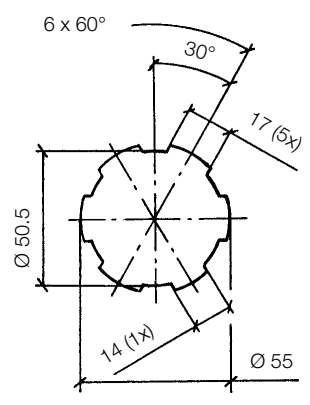

Thickness  
1.5 or 2 mm

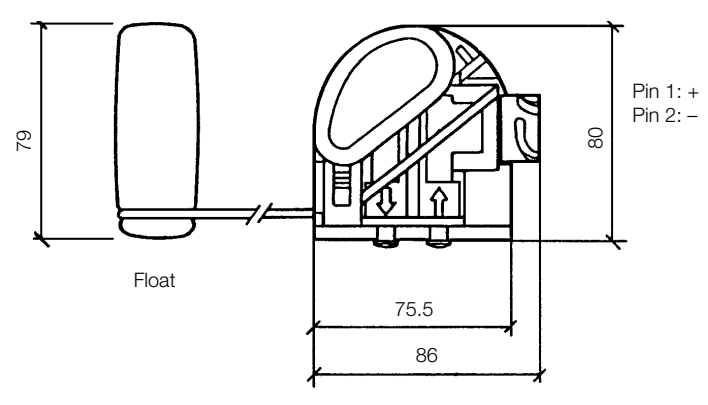

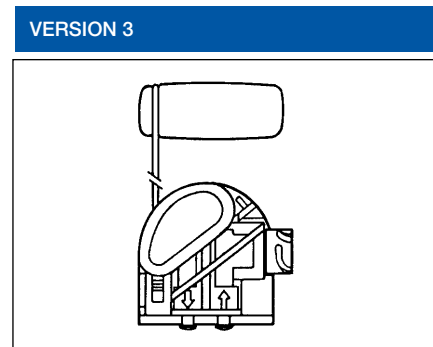
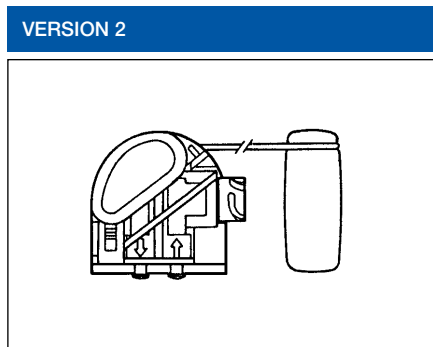
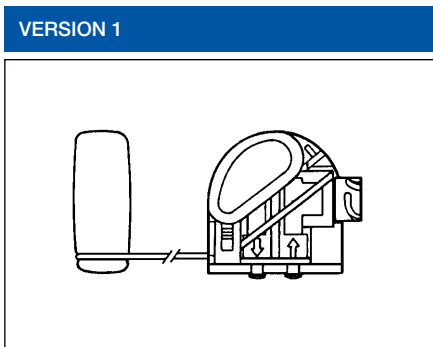

Order Part No.	Dimensions [mm]						Version
	L1	L2	L3	R	H	D	
	Depth required for installation Length from the bottom edge of the tube to empty	Length to the bottom edge of the float	Length to lever pivot point	Lever arm radius excl. float	Travel empty-full	Tank sheet thickness	
221-824-054-049C	405	393	274	238	310	1.5	2
221-824-054-050C	450	402	232	269	363	1.5	1
221-824-054-051C	492	482	190	325	430	1.5	3
221-824-054-056C	535	537	232	374	506	1.5	3
221-824-054-053C	568	485	274	311	423	2.0	1
221-824-054-052C	611	568	316	385	523	2.0	3
221-824-054-054C	670	625	316	418	570	1.5	3
221-824-054-055C	670	670	316	463	630	1.5	3

Order Part No.	Accessories	Pz. per Packing
89-356-017	O-ring (Gasket)	100
993-371-016	Fuel filter	4
X11-221-001-002	Inlet/Outlet connector	Bulk 20 pcs.
X11-221-001-003	Locking mechanism Inlet/Outlet or external heater	10
X11-221-001-004	external heater connector	Bulk 20 pcs.
N.D.	Bayonet connector DIN 72585 A1-2.1 SN/K1	

### 3.2.2 Adjustable Lever-arm Fuel Level Sender, Standard/ALAS I

#### STANDARD ADJUSTABLE LEVER ARM SENDER WITH ADJUSTABLE FLANGE

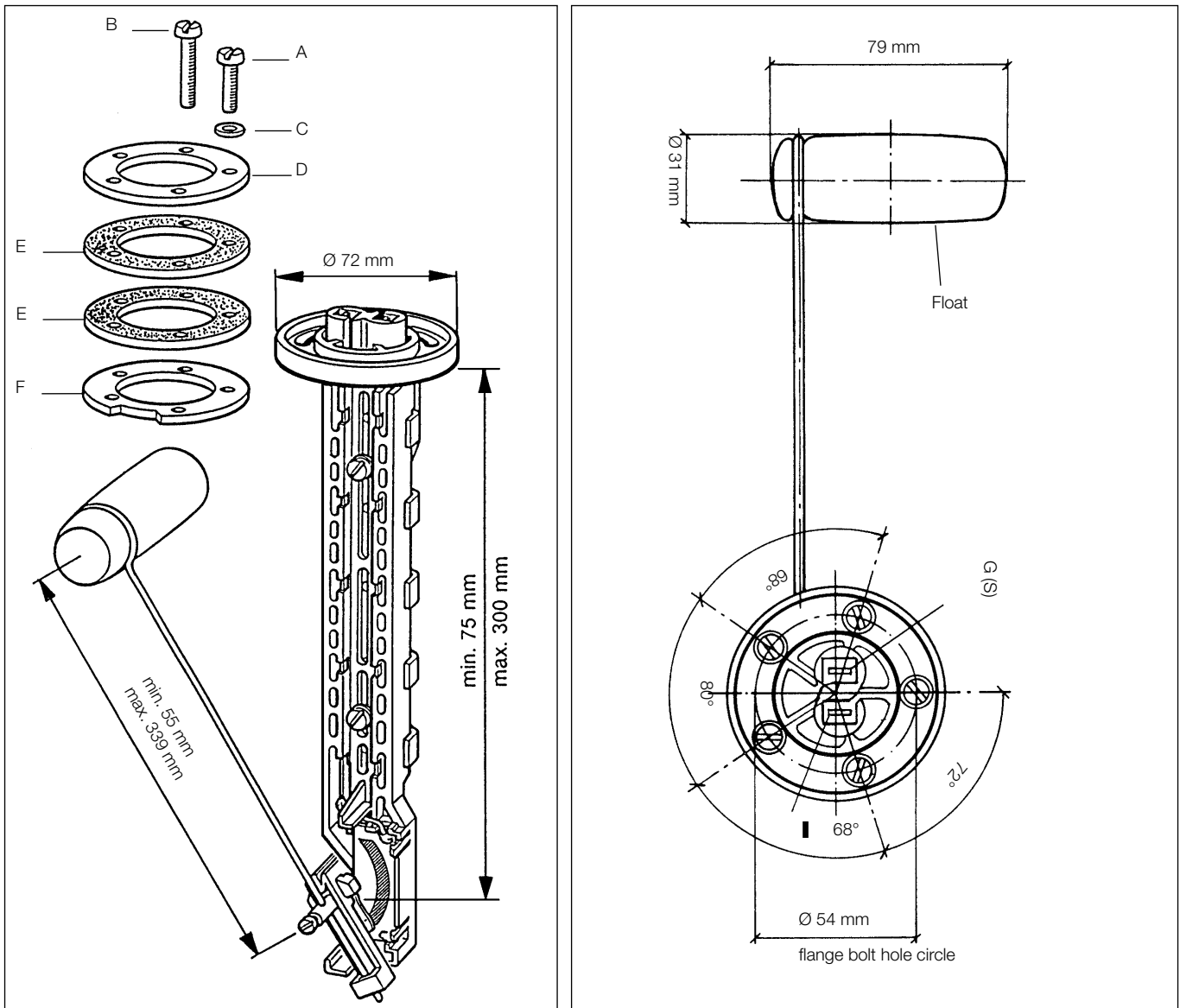

Order Part No.: 226-801-015-001G (single package)

Order Part No.: 226-801-015-001C (bulk 10 pcs.)

#### Technical features

Voltage	6–24 V (Insulated ground)		
Resistance	Empty	3 Ω	± 1.5 Ω
	Full	180 Ω	± 12 Ω
Operating temperature	-Bulk 20 pcs. °C a +65 °C		
Blade connector terminal (2-ways)	6.3 mm x 0.8 mm		
Tank flange	A	Screw M5 x Bulk	15 pcs.
	(4x)		
	B	Screw M5 x 30	(1x)
	C	Sealing washer	(5x)
	D	Flange	(1x)
	E	Gasket	(2x)
F	Slotted flange	(1x)	
For dual units (identified with "D")	N02-240-106		

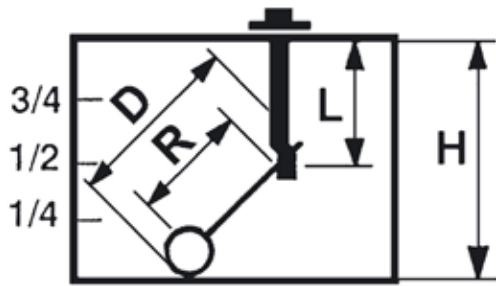

Install the lever in this position

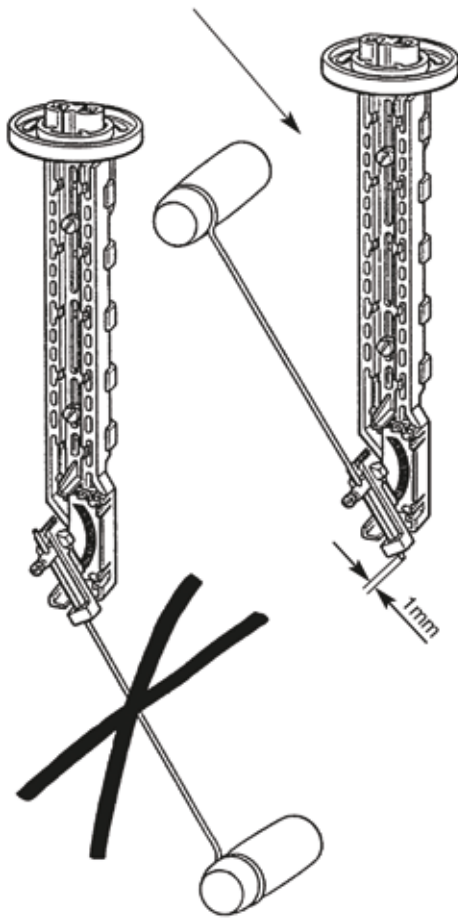

#### ADJUSTMENT

Adjust the Length (L) of the sensor and the distance (D) of the arm according to the height (H) of the tank

H	L	R	D
150	75	55	109
155	77.5	58	112
160	80	61	115
165	82.5	64	118
170	85	67	121
175	87.5	70	124
180	90	73	127
185	92.5	76	130
190	95	80	134
195	97.5	83	137
200	100	86	140
205	102.5	89	143
210	105	92	146
215	107.5	95	149
220	110	98	152
225	112.5	101	155
230	115	105	159
235	117.5	108	162
240	120	111	165
245	122.5	114	168
250	125	118	172
255	127.5	121	175
260	130	124	178
265	132.5	127	181
270	135	130	184
275	137.5	133	187
280	140	136	190
285	142.5	139	193
290	145	142	196
295	147.5	145	199
300	150	148	202
305	152.5	152	206
310	155	155	209
315	157.5	158	212
320	160	161	215
325	162.5	164	218
330	165	167	221
335	167.5	170	224
340	170	173	227
345	172.5	177	231
350	175	180	234
355	177.5	183	237
360	180	186	240
365	182.5	189	243
370	185	192	246
375	187.5	195	249

H	L	R	D
380	190	199	253
385	192.5	202	256
390	195	205	259
395	197.5	208	262
400	200	211	265
405	202.5	214	268
410	205	217	271
415	207.5	220	274
420	210	224	278
425	212.5	227	281
430	215	230	284
435	217.5	232	286
440	220	235	289
445	222.5	238	292
450	225	242	296
455	227.5	245	299
460	230	249	303
465	232.5	252	306
470	235	255	309
475	237.5	258	312
480	240	261	315
485	242.5	264	318
490	245	267	321
495	247.5	271	325
500	250	274	328
505	252.5	277	331
510	255	280	334
515	257.5	283	337
520	260	286	340
525	262.5	289	343
530	265	292	346
535	267.5	296	350
540	270	299	353
545	272.5	302	356
550	275	305	359
555	277.5	308	362
560	280	311	365
565	282.5	314	368
570	285	317	371
575	287.5	321	375
580	290	324	378
585	292.5	327	381
590	295	330	384
595	297.5	333	387
600	300	336	390
605	302.5	339	393

## A NEW GENERATION OF LEVER-ARM SENSORS

Our newly developed lever-operated fuel level sensors now offer our customers an extremely flexible and robust way to ensure reliable fuel measurement for tanks of different depths.

The system is based on an arm lever that generates a signal corresponding to the fuel level. The length of the lever arm can be adapted to specific requirements and shortened as required. This makes it possible to equip tanks of various depths (145 mm to 400 mm) using only one system, which is particularly advantageous with shallow tanks.

Two sensor versions are available: with and without reserve warning contact. The version with integrated warning contact generates a control signal when the fuel level in the tank falls below a predefined level, which can be used for example to turn on a light. A damping element that has already been successfully tested in marine use for many years allows the lever to compensate for the fluctuation of fuel in the tank. The reliable and robust design offers high precision readings and is available for a wide range of applications, from small machines to large mobile and stationary vehicles.

### ALAS I



Flexible adjustment for tank depths from 145 to 400 mm.

#### Wide range of applications

- Small engines and construction machines (mini-excavators, dumpers, compressors, etc.).
- Processing and agricultural machines
- Marine applications (sport and leisure boats, jet skis, etc.).
- Two-wheeled vehicles (motorcycles, scooters, etc.).
- Micro cars, quad bikes.
- Stationary machines (compressors, gen-sets).



Order Part No.: N05-801-432

#### Mounting kit

(available separately, not included as standard)

#### Features

- Adjustable lever-arm fuel level sender
- Available with or without reserve warning contact.
- Ø 54 mm - standard flange.
- 3 different resistive range (DSN thick-film technology) for use with standard gauges
- Direct adaptation to different depths of the tank thanks to an easily adjustable lever arm.
- Robust Design
- Long life cycle, redundant contact system.
- Lever in stainless steel.
- Nitrile rubber float - it does not sink if damaged
- Protected electrical connections.
- Elongated holes for a flexible installation.
- The bearing with backlash compensation guarantees a prolonged life cycle, continuously compensating the action of the waves that hits the boats, for example.
- Long-lasting resistive element (1 million "full/empty" cycles with unloaded petrol).

## Dimensions [mm]

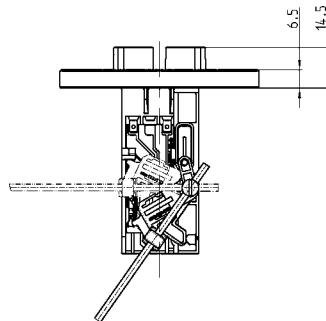
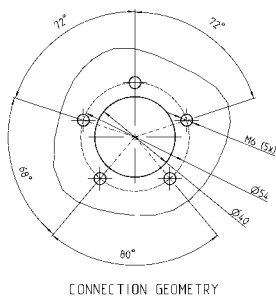
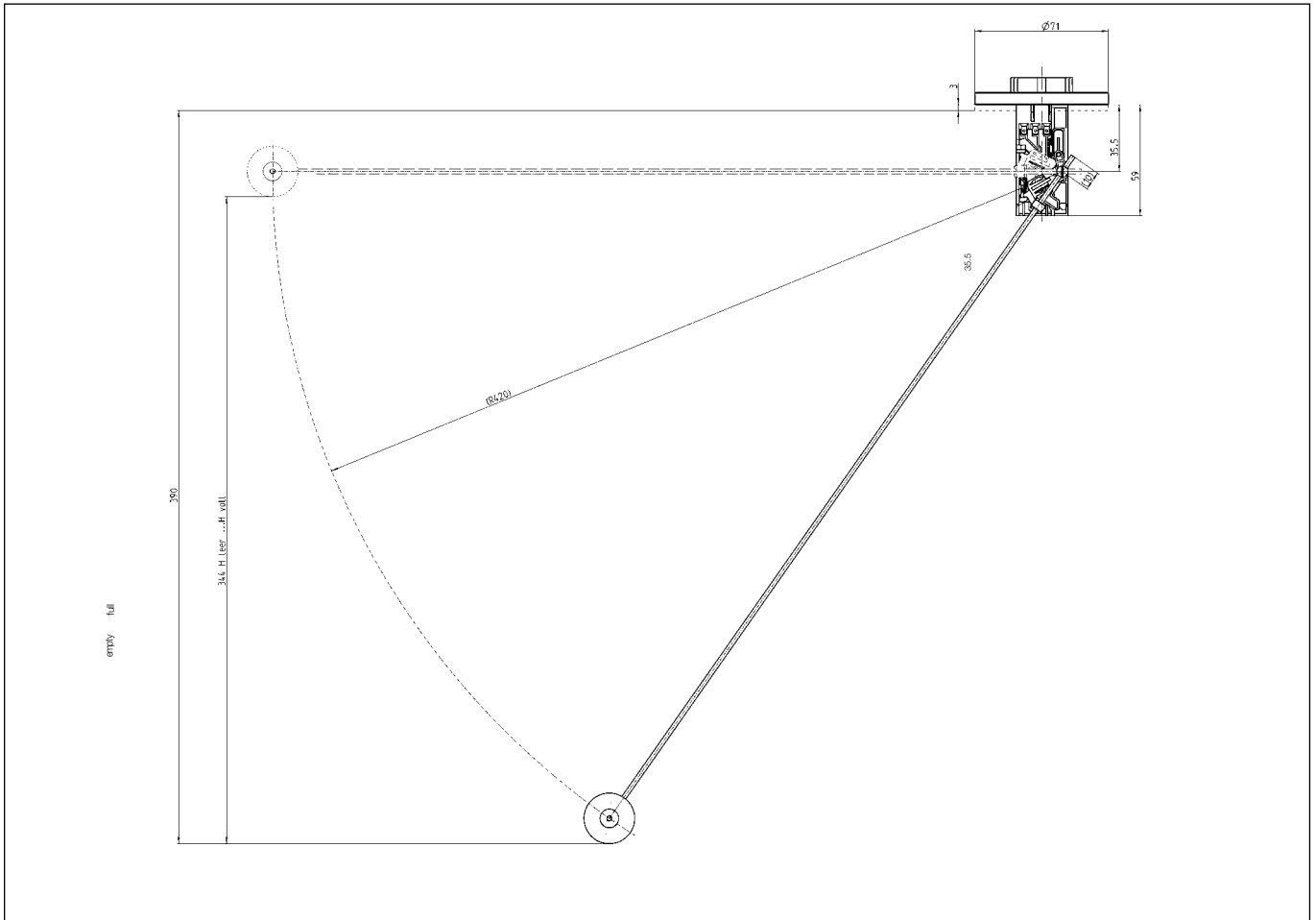

Features ALAS I (full-empty)	180-2.5 $\Omega$ with warning contact	180-2.5 $\Omega$ without warning contact	33.5-240 $\Omega$ with warning contact	33.5-240 $\Omega$ without warning contact	90-2 $\Omega$ with warning contact	90-2 $\Omega$ without warning contact
Order Part No. 1 pz	A2C59510165	A2C59510171	A2C59510166	A2C59510172	A2C59510167	A2C59510173
Order Part No. 2 pz	A2C59510162	A2C59510168	A2C59510163	A2C59510169	A2C59510164	A2C59510170

## Technical features

Tank depth	from 145 to 400 mm
Voltage	6–24 V, Insulated ground
Resistive range	<ul style="list-style-type: none"> <li>• 3 <math>\Omega</math> (empty) to 180 <math>\Omega</math> (full)</li> <li>• 240 <math>\Omega</math> (empty) to 33.5 <math>\Omega</math> (full)</li> <li>• 2 <math>\Omega</math> (empty) to 90 <math>\Omega</math> (full)</li> <li>• warning contact at 15% of the remaining volume</li> <li>• resolution measurement on 39 discrete levels</li> </ul>
Mounting geometry	5-hole flange with 54mm diameter
Electrical connection	6.3 mm x 0.8 mm (2 x) 2.8 mm x 0.8 mm (1 x)* *only version with reserve warning contact



## 4. Control Systems

- 4.1 Pedal Interface II\*
- 4.2 AGB III\*
- 4.3 E-Gas® Compact\*
- 4.4 Actuators
- 4.5 KIBES - Key to Integrated onBoard Electronic System\*
- 4.6 gVCU (generic Vehicle Control Unit)
- 4.7 DC-DC converters

\* Only for trained partners

## 4.1 Pedal Interface II

Pedal Interface II consists of an electronic controller installed between the accelerator pedal and the vehicle engine management unit. It has been designed to perform the function of maximum speed limiter for vehicles of category M2 and N2 (trucks up to 35q and mini-buses for passenger transport) as well as adapting, thanks to its versatility, to many uses and applications for Industrial and Special vehicles

### Applications:

- Maintaining Cruise Speed (Cruise Control) by Lever (optional)
- Variable speed limitation by lever (optional)
- Limitation of the maximum speed
- Special speed limitation (in presence of input signal, e.g. man on the platform)
- Engine rev limitation (RPM)
- Engine speed control, fixed RPM
- Engine speed control, variable RPM

### COMPONENTS, TYPE 1 AND TYPE 2 (THE KITS INCLUDE WIRING AND FIXING PARTS, "ECU" REFERS ONLY TO THE CONTROL UNITS)

Order Part No. KIT	Order Part No. ECU	Description	Type
X10-737-100-001	X39-737-100-001	3-analog channels (tempostat®)	Type 1 Standard
X10-737-101-001	X39-737-101-001	3-analog channels (tempostat® + speed and RPM limiter)	Type 1 Enhanced
X10-737-102-001	X39-737-102-001	3-analog channels (tempostat® + speed and RPM limiter + controllo Motor)	Type 1 Premium
X10-737-200-001	X39-737-200-001	2-analog channels + 2 contacts (tempostat®)	Type 2 Standard
X10-737-201-001	X39-737-201-001	2-analog channels + 2 contacts (tempostat® + speed and RPM limiter)	Type 2 Enhanced
X10-737-202-001	X39-737-202-001	2-analog channels + 2 contacts (tempostat® + speed and RPM limiter + engine RPM ontrol)	Type 2 Premium

Technical characteristics	
Voltage supply	12 V / 24 V
Operating voltage	8–32 V
Current consumption	Tmnl. 15 < 1 mA; Tmnl. 30 < 80 mA (< 10 mA standby)
Operating temperature	from -40 °C to +85 °C (IEC 68-2-38)

### ECU (SEE "ORDER PART NO. ECU" )



Technical specification	
Low and High temperature	<ul style="list-style-type: none"> <li>• ISO 16750 Part 4, Section 5.1.1.2 e 5.1.2.2</li> <li>• BS EN 60068-2: 1993 Test Ab</li> <li>• BS EN 60068-2: 1993 Test Bb</li> </ul>
Vibration test in temperature cycles	<ul style="list-style-type: none"> <li>• ISO 16750-3: 2003 Electrical e electronic equipment - Mechanical loads</li> <li>• IEC 68-2-64: 1993, Vibration, broadband random: Method 2</li> <li>• BS EN 60068-2-14: 2000 Test Nb, Environmental testing</li> </ul>
Thermal shock	<ul style="list-style-type: none"> <li>• ISO 16750 Part 4, Section 5.3.3</li> <li>• BS EN 60068-2-14: 2000 Test Na</li> </ul>
Temperature and umidity	<ul style="list-style-type: none"> <li>• ISO 16750 Part 4, Section 5.6.2</li> <li>• BS EN 60068-2-38: 1999</li> </ul>
Temperature cycles	<ul style="list-style-type: none"> <li>• ISO 16750 Part 4, Section 5.3.2</li> <li>• BS EN 60068-2-14: 2000 Test Nb</li> </ul>
Approval according to EU directive	Speed limitation devices 92/24 (Enhanced e Premium versions only) EMC 2006/96 EG
Official nomination from experts	Tempostat functionality tested by a test authority prescribed for the approval of motor vehicles and their systems, Germany



## Accessories Pedal Interface II

Order Part No.	Description	
X39-737-300-008	Harness lenght. 1,5 mt	
X39-737-003-003	Manual control interface for remote engine speed adjustment. Cable length: 7mt, digital signal.	
X12-737-100-002	Pedal Interface DONGLE Level 2: Hardware key for the workshop that allows the download of the master file, access to all the functions and the diagnosis of the system	
X12-737-100-003	DONGLE Pedal Interface Level 3: Hardware key for the workshop that allows the download of the master file, access to the functions of Cruise Control, RPM regulation and system diagnosis	
X39-397-106-149	Cruise control lever and variable speed limitation	
X39-737-300-004	Cruise control lever and variable speed limitation, with signal LED. Installation position: RIGHT	
X39-737-300-005	Cruise control lever and variable speed limitation, with signal LED. Installation position: LEFT	
X39-737-300-006	Cruise control lever and variable speed limitation, with flexible joint. Installation position: RIGHT	
X39-737-300-007	Cruise control lever and variable speed limitation, with flexible joint. Installation position: LEFT	

## 4.2 AGB III

### Road speed limiter

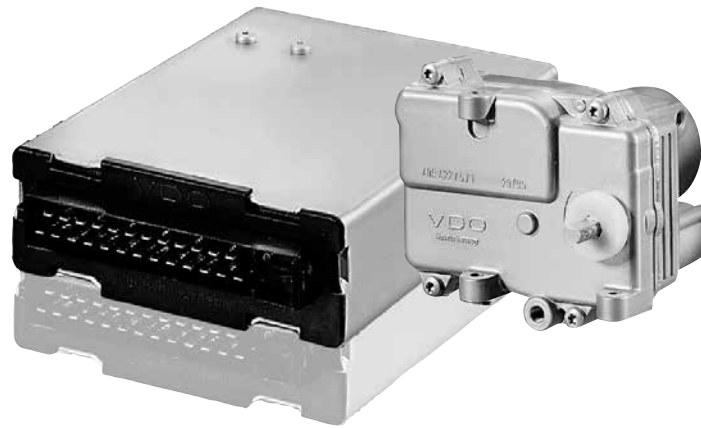
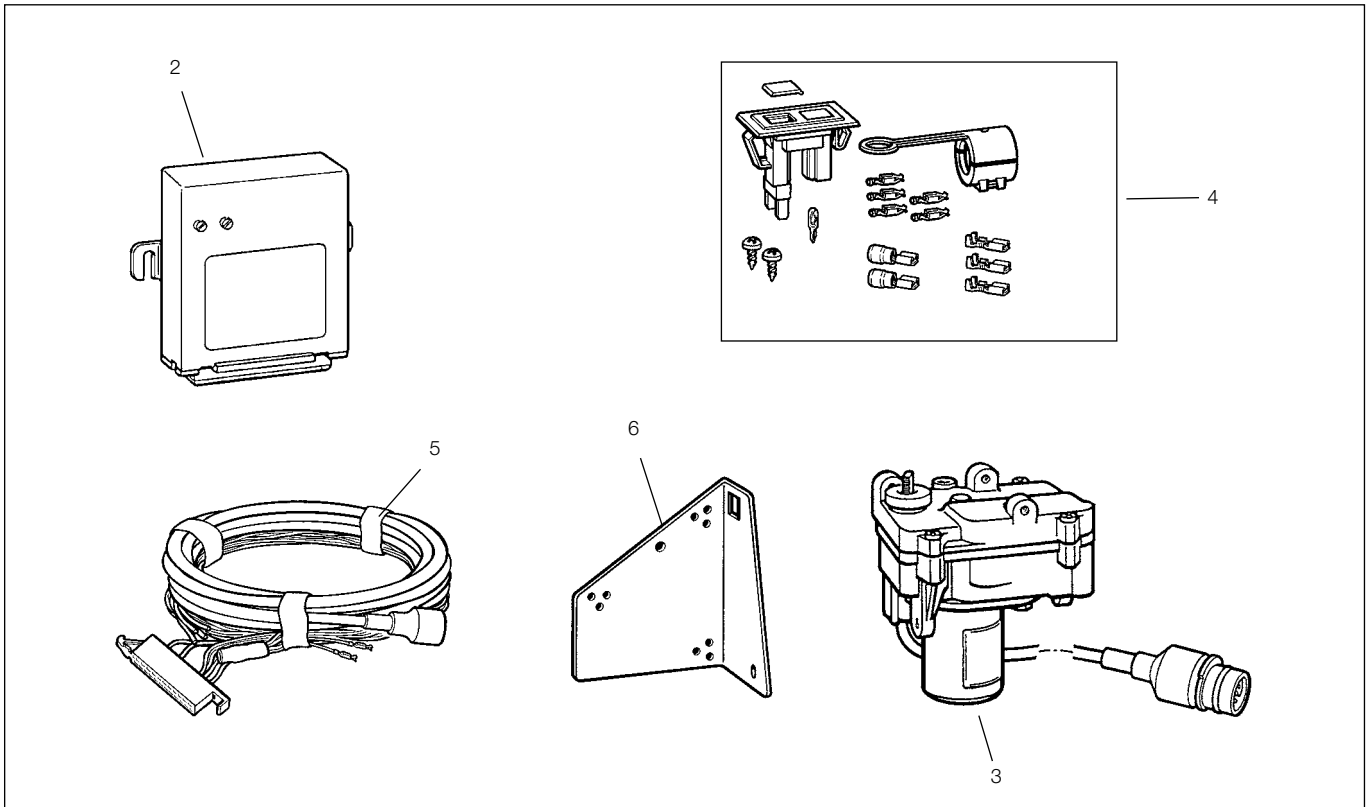

Fig. 1 - Components of theKIT (12V or 24V) - Speed limit pre-set to 85km/h



Order Part No.	Description	Picture
X10-397-109-131	AGB III Basic Kit 12 V	1
X10-397-109-132	AGB III Basic Kit 24 V	1
<b>SPARE PARTS</b>		
A2C53091782	Contro Unit 12/24 V	2
408-221-001-001 P	Actuator 12 V	3
408-422-001-014 G	Actuator 24 V	3
X39-397-109-027	Set on electric components	4
X39-397-109-030	Harness	5
X11-397-001-033	Actuator bracket	6

## 4.3 E-Gas<sup>®</sup> Compact

Electronic accelerator, road speed limiter and engine RPM controller

### Electronics

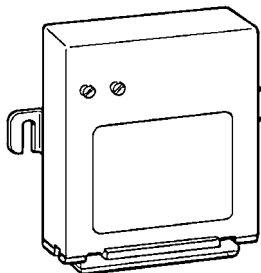

Order part No.: 412-413-011-002P\*

#### Technical data

Rated voltage	12 V / 24 V
Operating Voltage	9.5- 32 V
Operating temperature	-40 °C to +70 °C
Protection rating	IP53 DIN 40050
Installation location	Passenger compartment
Orientation	Electrical connection facing down (minimum 5°)
Max. fixing torque	25-pole AMP

### Descriptor

This electronic controller is designed for use in industrial and special vehicles.

The system operates the fuel control lever of an internal combustion engine by means of an Actuator, which moves according to a set of predefined set points. All input signals and outputs are processed from an integrated 16-bit processor. Thanks to the flexibility of its design, the controller can be programmed to meet a wide range of requirements, such as:

- Pedal - "drive by-wire".
- Control and limitation of the engine speed.
- Control and limitation of the vehicle road speed.
- Position limitation of the actuator.

A PC-based customized software tool allows access to the controller, if required, via the diagnostic interface, in order to change the calibration or read diagnostic error codes.

The controller complies with the following standards:

- EMC directive 2006/96 / CE on vehicles.
- 92/24 /CEE directive related to speed limitation devices.
- DIN 40839 Interference conducted along supply lines.

### Dimension [mm]

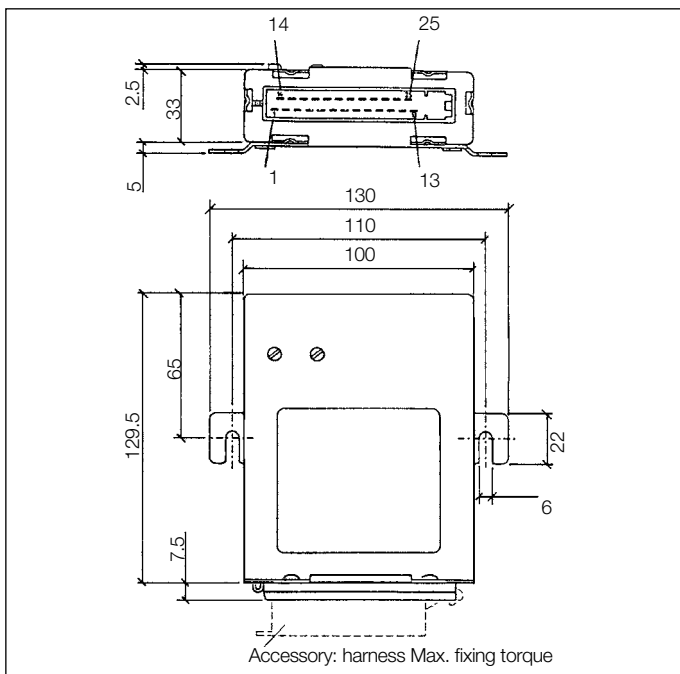

#### Max. fixing torque Pin-out

- 1 Ignition terminal (+15/54)
- 2 Motor (-)
- 3 Clutch contact
- 4 Activation fixed RPM control
- 5 Pedal signal PWM 1
- 6 Prog. limiter
- 7 tempostat<sup>®</sup> memo
- 8 Brake signal
- 9 Speed signal
- 10 Actuator feedback
- 11 Actuator potentiometer feedback positive (+)
- 12 Actuator potentiometer feedback negative (-)
- 13 Fault light
- 14 Terminal -31 (ground)
- 15 Motor (+)
- 16 tempostat<sup>®</sup> OFF
- 17 Pedal signal PWM 2
- 18 Clutch
- 19 Tempostat<sup>®</sup> S-B
- 20 Tempostat<sup>®</sup> S+B
- 21 Speed signal
- 22 N.c.
- 23 Diagnostic line (K-line)
- 24 Actuator potentiometer feedback signal
- 25 Analog input

Order Part No.	Description
X11-397-109-003	Cable Max. fixing torque, black
X11-397-109-004	Max. fixing torque sleeve

## SET POINT SENDER

### COMPONENT OF THE SYSTEMS E-GAS® II, E-GAS® COMPACT

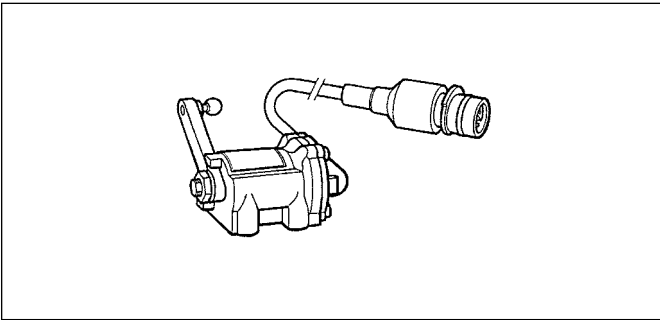

Order part No.: 445-804-005-014P

### Description

The set point transmitter consists of a potentiometer to convert the position of the pedal into an electrical signal. The signal of the potentiometer is proportional to the position of the lever which is in turn mechanically connected to a pedal or to an acceleration lever.

A safety contact (SK) and a kick-down contact (KD) are operated within a predefined interval. The safety contact corresponds to a specific value of the potentiometer.

A fatigue-resistant spring body is located inside the transmitter to give the right mechanical feedback to the operator.

### Technical characteristics

#### Supply from ECU

Operating temperature	from -40 °C to +80 °C
Initial torque	160 Ncm <sup>+20 Ncm</sup> <sub>-30 Ncm</sub>
Final torque	280 Ncm ± 40 Ncm
Kick down torque	550 Ncm ± 70 Ncm
Histeresis	50 Ncm ± 20 Ncm without load 50 Ncm ± 20 Ncm full load
Protection class	IP66 DIN 40050
Maximum fixing torque: 8 Nm + 4 Nm (screwing depth 9mm)	
Max. fixing torque	ITT Canon Sure Seal, 7-pin

### Dimension [mm]

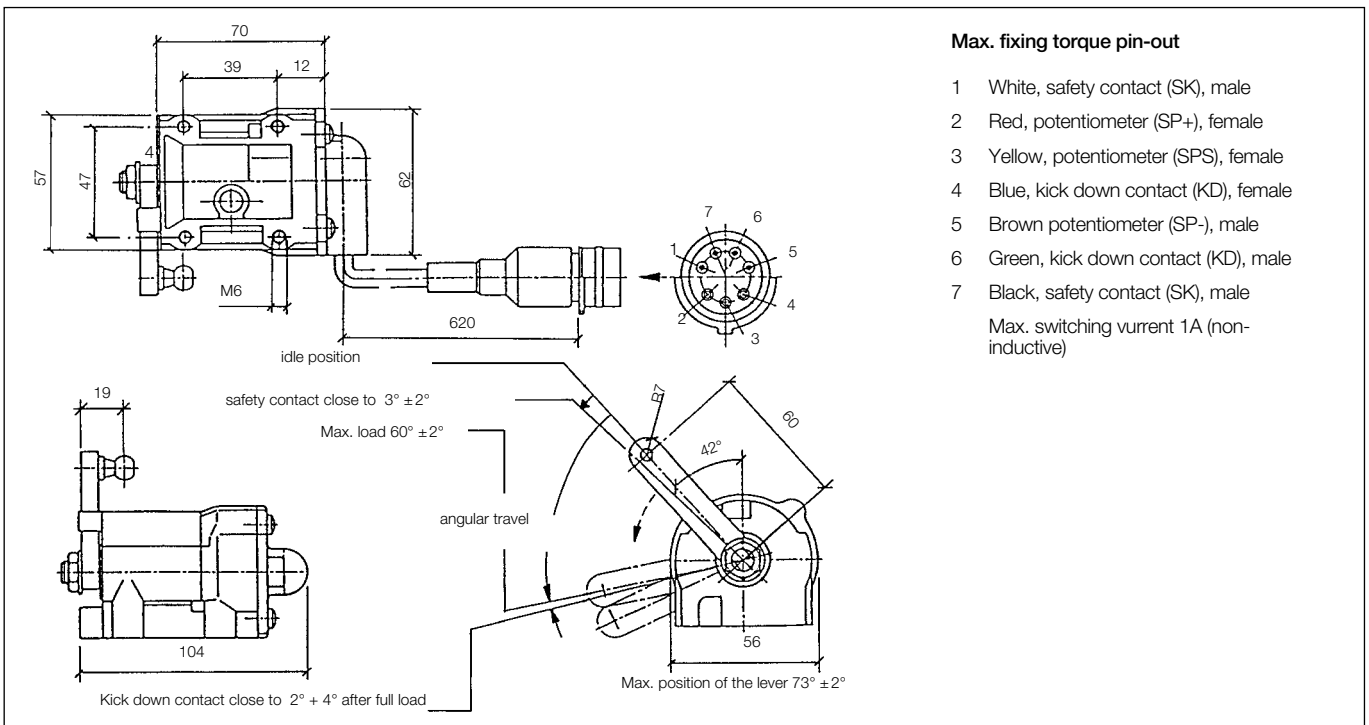

### SOFTWARE

#### Order Part No.

X12-397-051-001	E-Gas® Compact Testsoftware V.4002 WinXP
X12-397-046-001	E-Gas® Compact Testsoftware V.4002 WinXP interface included

## 4.4 Actuators

### ELECTRIC ACTUATORS

#### COMPONENT OF THE E-GAS® COMPACT SYSTEM

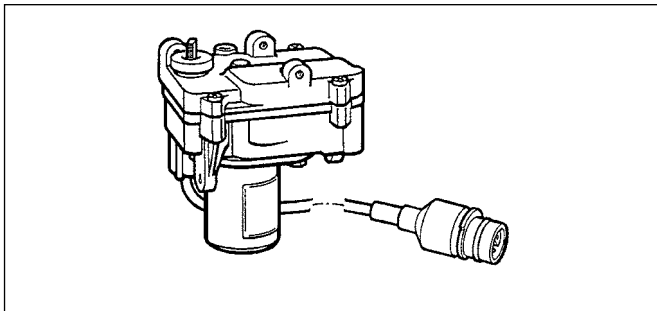

Order part No.: 408-422-006-001G

#### Description

This electric Actuator was designed from VDO for the purpose of operating the diesel engine injection pump lever in combination with a VDO electronic controller. A pulse width modulated signal (PWM) is used to control the DC motor to permanent magnet.

#### Costruction

Die-cast aluminum body with PTFE diaphragm for pressure equalization. The three-stage transmission transfers the force from the motor to direct current to the output shaft by an electromagnetic clutch. A conductive plastic potentiometer provides feedback. Connection cable with Max. fixing torque.

#### Technical characteristics

Nominal Voltage	24 V
Nominal torque	250 Ncm
Travel time from idle to full position	≤ 1 s
Travel time from idle to full position (typical)	750 ms
Insulation resistance	≥ 500 kΩ
Dielectric strenght	500 V
Operating temperature	from -25 °C to +90 °C
Protection class	IP56 DIN 40050 part 9
Max. torque transmission shaft	10 Nm
Max tightening torque	12 Nm (to 9 mm screwing depth)
Max. fixing torque	103° ± 5°
Connector	ITT Canon Sure Seal, 7-pin

#### Dimension [mm]

**Connector pin-out**

- 1 Motor (-)
- 2 Potentiometer (IP-)
- 3 Potentiometer (IPS)
- 4 Potentiometer (IP+)
- 5 Clutch
- 6 Clutch
- 7 Motor (+)

Order Part No.	Description
X39-397-112-014	2 bracket sets for the mounting to the engine

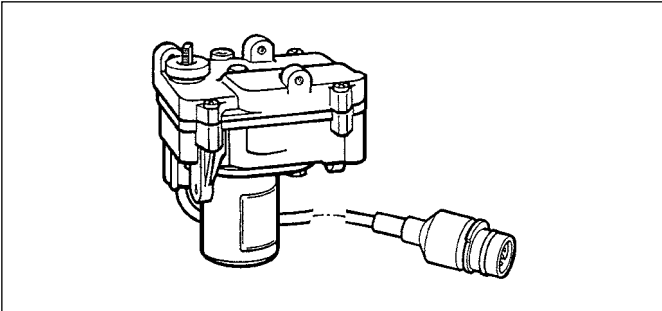

Order part No.: 408-221-005-001G

### Description

This electric Actuator was designed from VDO for the purpose of operating the diesel engine injection pump lever in combination with a VDO electronic controller. A pulse width modulated (PWM) signal is used to control the Motor CC to permanent magnet.

### Costruction

Die-cast aluminum body with PTFE membrane for pressure equalization. The three-stage transmission transfers the force from the DC motor to the output shaft via an electromagnetic clutch. A conductive plastic Potentiometer provides feedback. Connection cable with Connector.

### Technical characteristics

Nominal Voltage	12 V
Nominal torque	400 Ncm clockwise (AGB) 300 Ncm clockwise (tempostat®)
Travel time from idle to full position	≤ 2 s
Insulation resistance	≥ 500 kΩ
Dielectric strenght	500 V
Operating temperature	from -25 °C to +90 °C
Protection class	IP56 DIN 40050 Part 9
Max. torque transmission shaft	10 Nm
Max tightening torque	12 Nm (to 9 mm screwing depth)
Angle of mechanical travel	103° ± 5°
Connector	ITT Canon Sure Seal, 7-pin

### Dimension [mm]

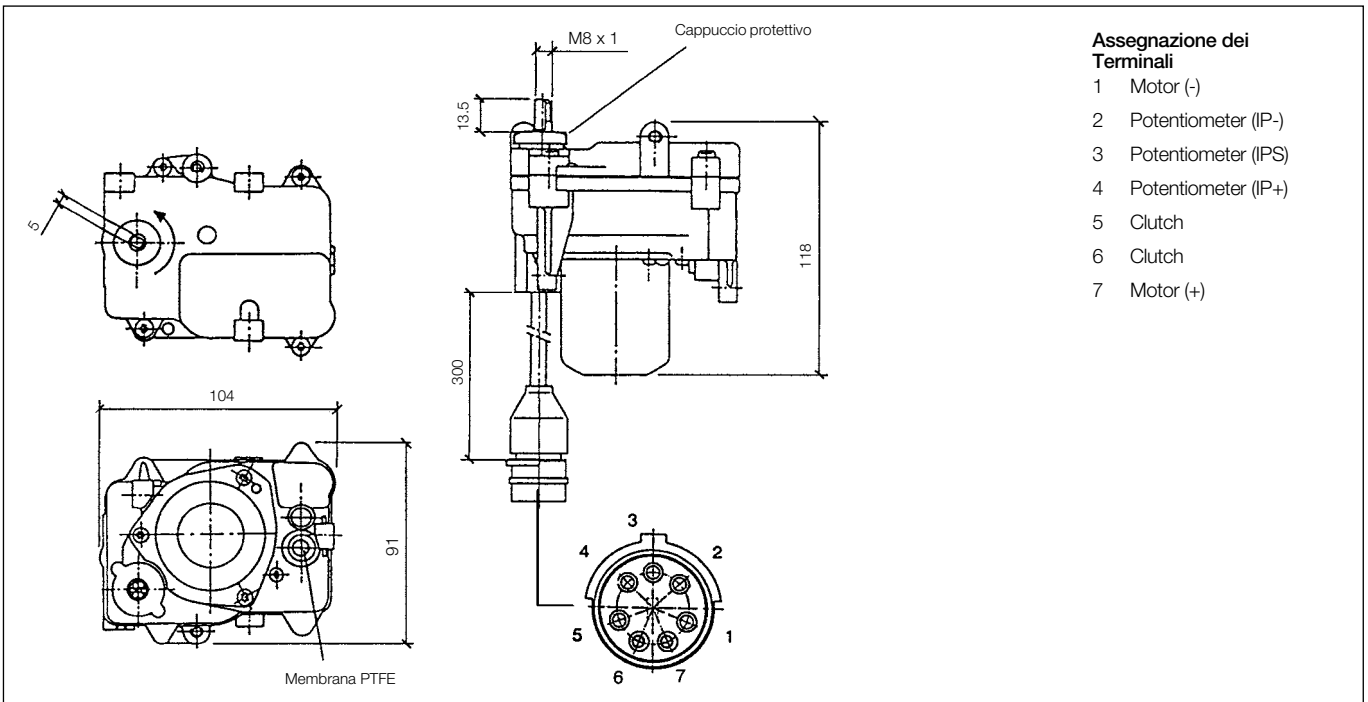

### Assegnazione dei Terminali

- 1 Motor (-)
- 2 Potentiometer (IP-)
- 3 Potentiometer (IPS)
- 4 Potentiometer (IP+)
- 5 Clutch
- 6 Clutch
- 7 Motor (+)

Order Part No.	Description
240-110-001-001P	Anti vibration set
X39-397-112-014	Bracket set for the mounting to the engine

## ELECTRIC ACTUATOR

### COMPONENT OF E-GAS® II, E-GAS® COMPACT SYSTEMS

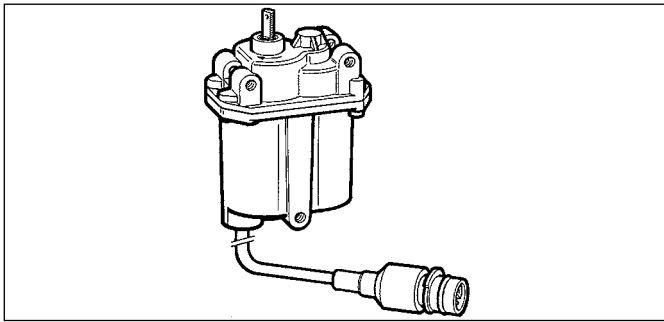

#### Description

This electric Actuator was designed from VDO for the purpose of operating a diesel engine injection pump lever in combination with a VDO electronic controller.

#### Construction

Die-cast aluminum body with PTFE diaphragm for pressure equalization. Three-stage transmission permanently engaged with the output shaft. A potentiometer with conductive traces provides feedback. It has a safety contact that opens when the output shaft is in a predefined position. Connection cable with Max. fixing torque.

Order part No.: 408-411-005-013P (24 V) | 408-211-004-002P (12 V)

#### Technical characteristics

Nominal Voltage supply	24 V or 12 V
Nominal torque	180 Ncm (used with control ECU)
Actuation time	< 250 ms at the nominal voltage 100 to 180 Ncm of actuation torque
Commutation point safety contact	21° to 12.5° (closed without load)
Operating temperature	from -40 °C to +120 °C (+140 °C max. 1 x 1h)
Protection class	IP56 DIN 40050
Angle of mechanical travel	120°
Max. tightening torque of the trasmission shaft	10 Nm
Max. tightening torque of the fixing screws	8 Nm + 4 Nm (to 9 mm of screwing depth)
Max. fixing torque	ITT Canon Sure Seal, 7-pin

#### Dimension [mm]

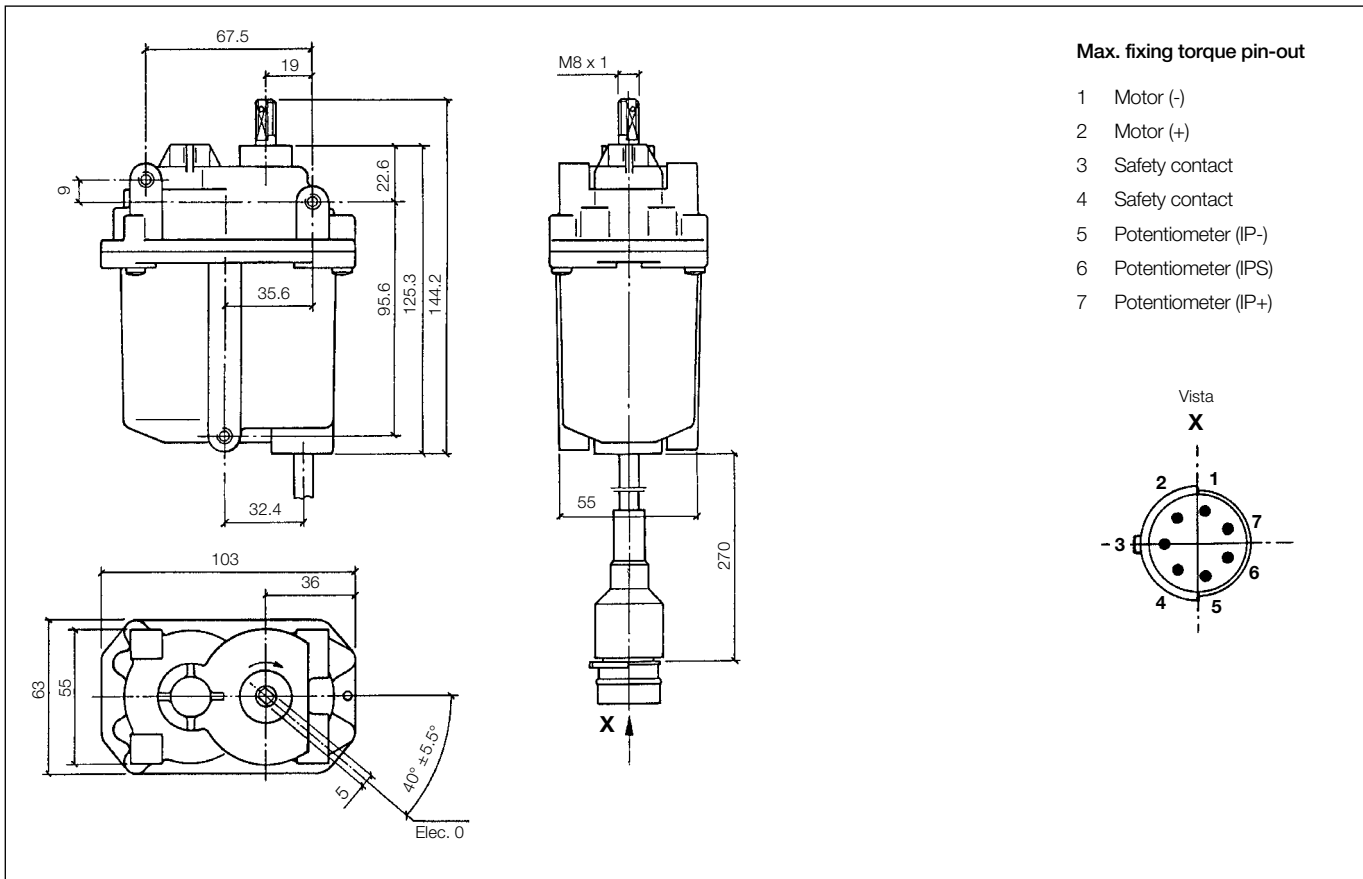

Order Part No.	Description
240-110-001-001P	Anti vibration set
993-620-079-1143	Lever (angled)
993-620-082-1143	Lever (straight)

## 4.5 KIBES (Key to Integrated OnBoard Electronic Systems)





### Sistemi Multiplex for the vehicle control

In modern vehicles and machines, the demands in terms of efficiency, comfort and functionality is increasing. Continental's Multiplex solutions can meet this challenge in the future.

From the oversized fixed wiring and conventional electronics, there will be the transition to flexible architecture with decentralized intelligent power and diagnosis, direct interface to the driver's display and Gateways for data buses.

#### Central computers (Master)

Central computers represent the heart of the Multiplex system. They are specially programmed to manage the functionality of multiplex nodes and any instrument groups inserted in the system. They are equipped with numerous communication interfaces, diagnostic services and their own I/O.

	ZR5-TO	CBCU	MUX5-PCU	MUX4-PN
				
	<ul style="list-style-type: none"> <li>Central computer for vehicle control</li> <li>Gateway functionality</li> <li>It manages up to 18 nodes</li> <li>ISO 26262 up to ASIL B</li> </ul>	<ul style="list-style-type: none"> <li>Management of analog and digital inputs</li> <li>Management of power outputs with diagnostic function</li> <li>Expandable with multiplex nodes</li> </ul>	<ul style="list-style-type: none"> <li>Master with 2 CAN Multiplex and 4 generic</li> <li>High power outputs</li> <li>Waterproof, installable outside the cabin</li> <li>Functions of diagnostics</li> </ul>	<ul style="list-style-type: none"> <li>Smart gateway for cabin installation</li> <li>Excellent solution as a body controller</li> <li>Multiple I / O controllers with diagnostic and protection functions</li> </ul>
Dimension (mm) LxBxH	162 x 165 x 30	276 x 185 x 43	*	155 x 111 x 40
Nominal Voltage	12V - 24V	24V (12V optional for CBCU3-EL)	12V - 24V	24V
Operating Voltage	9V - 32V	9V - 32V	*	18V - 32V
Operating temperature	-40°C +85°C	-40°C +85°C	-40°C +85°C	-30°C +7°C
IP protection	IP40	IP30 (IP54 with additional cover)	IP67 (IP6K9K)	IP40
Processor	32 bit ARM based core	32 bit RISC	*	32 bit RISC
Internal flash	4 MByte	1024kByte	*	512kByte
Internal SRAM / external EEpro	512kByte / 32kByte	256kByte / 32kByte	*	128kByte, 2kByte
Digital Inputs	8 (4 possibili per wake up)	34(8mA), 16(1mA)	16	8 (opzionali 12 o 24)
Analog inputs (parametric)		6	16	2 (opzionali 3)
HIGH Side Outputs		1(7,5A), 3(5,6A), 3(3,6A), 6(2,7A), 10(2,8A), 5(1A), 4(0,2A - di cui 1PWM)	16(3A), 8(2A, PWM@400Hz)	6(1,5A), 10(0,5A)
LOW Side Outputs	9(0,1A)	2 (configurable PWM)	2 (10A, Half Bridge)	1(0,5A), 1(0,1A)
Supply for sensors		1(5V), 2(8V)	1(5V), 2(8V)	-
CAN Interfaces	8 total	3	6 total	2
Other communication interfaces	LIN	LIN (Solo CBCU3-EL)	LIN(2), SENT(2), PSI5	
Wake Up	Digital Inputs, CAN, LIN	Digital Inputs	2 Digital Inputs	1 Digital Input
Diagnostic services	DM1, UDS, ASAM	DM1, UDS, ASAM, KWP2000	*	DM1, UDS, ASAM, KWP2000
Frequency inputs	speed, RPM	speed, RPM	4	1
*Information reported in detail only on the technical manuals of the device				



Possible system architectures based on ZR5-To and CBCU central computers for chassis and vehicle control are given as examples. Maximum configuration with ZR5-A

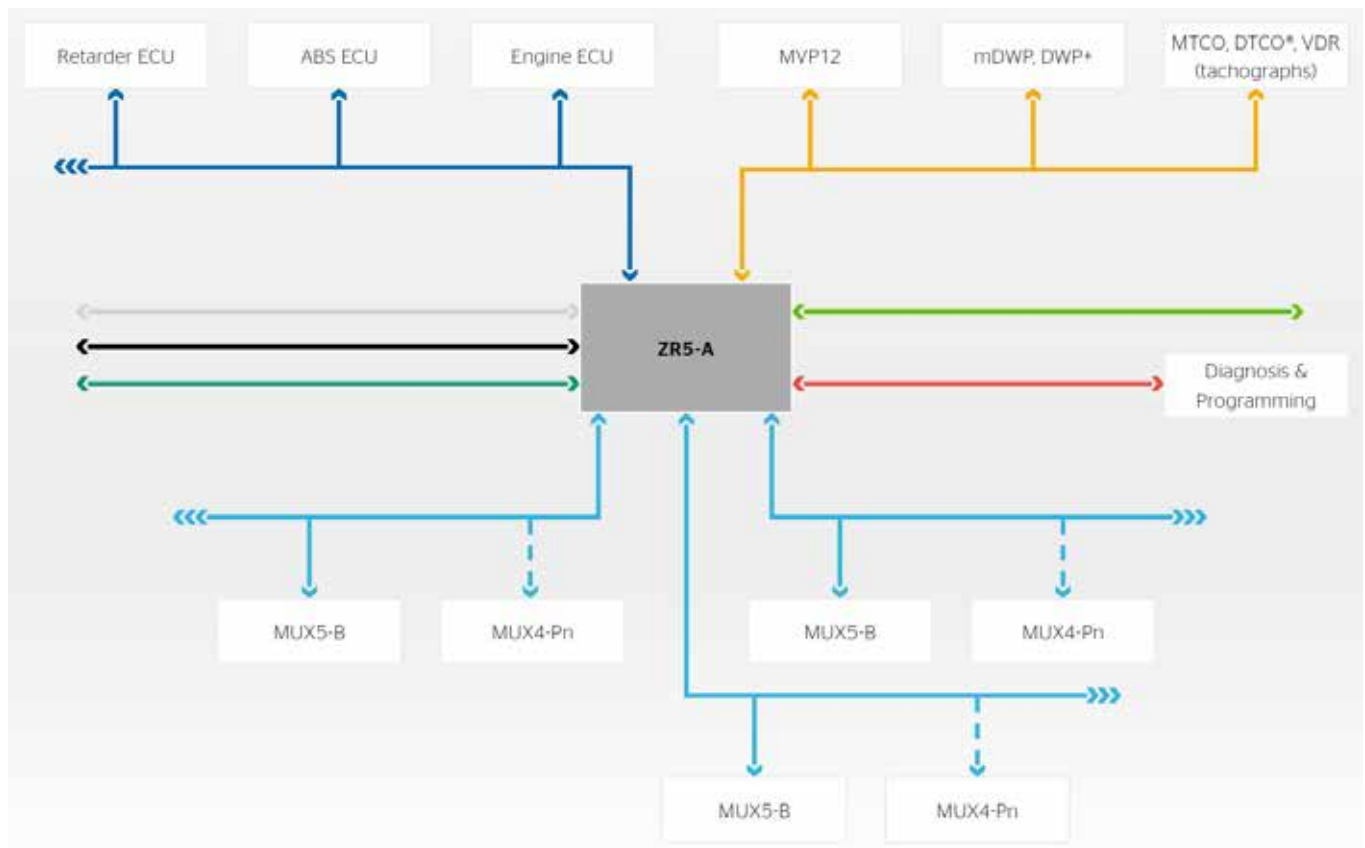

Maximum configuration with CBCU

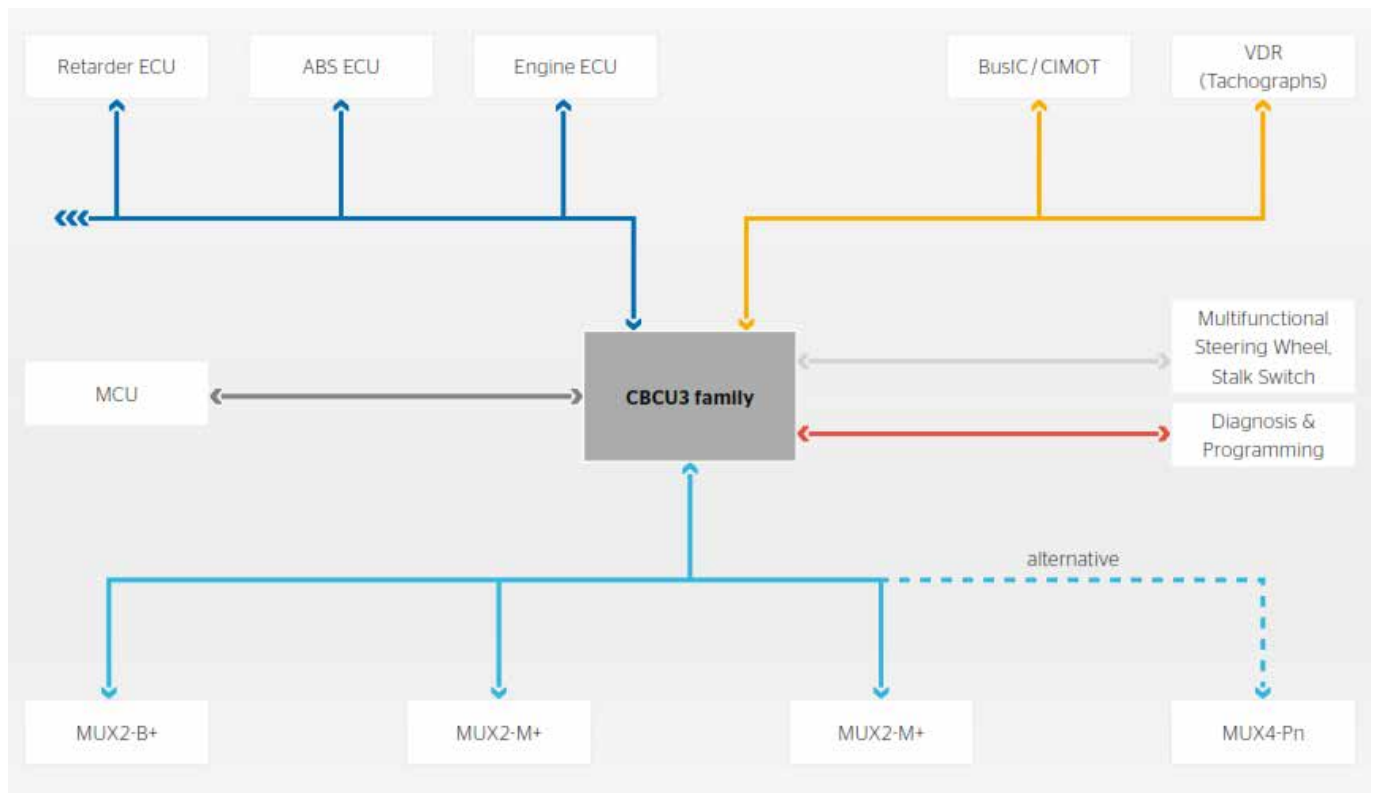



## Multiplex nodes

Devices with a high number of Inputs and Outputs to decentralize the various parts of the vehicle electrical system and the activation of loads and controls. They are equipped with CAN bus dedicated to communication with central computers (Master)

	MUX5-B	M,UX2-B+	MUX2-M+	MUX4-PN
Dimension (mm) LxBxH	258 x 155 x 30	258 x 55 x 30	162 x 165 x 30	258 x 55 x 30
Nominal Voltage	12V e 24V	12V e 24V	12V e 24V	12V e 24V
Operating Voltage	8-32V	8-32V	8-32V	8-32V
Operating temperature	-40°C ... +85°C	-30°C ... +70°C	-30°C ... +70°C	-40°C ... +85°C
IP protection	IP40	IP40	IP40	IP67
Digital Inputs	20	24	12	8
Analog Inputs (parametric)	10	6	2	8 (also usable as digital)
HIGH Side Outputs	2(9A), 4(5A), 6(3A), 8(1A), 4(0,3A)	2(10A), 4(5A), 10(3A), 8(1A)	14(3A)	2(8A), 6(6A), 3(5A), 5(3,3A), 6(1,1A)
LOW Side Outputs	8 (1A, 4PWM)	8 (1A, 4PWM)	2(1A, HB Switch, PWM)	
Half Bridge Outputs	4(3A)			
Wake Up	CAN	CAN	CAN	2 Digital Inputs
Supply for sensors	2(20mA)	-	-	5V, 40mA
Max total current	25A	30A	25A	67.5A

## Instrument Clusters

MULTIVIU PROFESSIONAL 12"	CIMOT	MOKI 3	BUS IC
			
Multiviù Professional 12 is the most innovative cluster. It consists of a TFT to color display with fully programmable graphics and functionality.	It is composed of 4 analogical instruments, a large number of warning and alarm lights and a programmable monochrome TFT display, with the possibility of containing diagnostic messages, indication bars, icons and company logos.	Moki3 is the most flexible and reliable solution to manage small series productions. The TFT to color display and the possibility of customizing various components have made Moki3 the most widespread instrument cluster among bus manufacturers.	It is the ideal instrument for the integration in citybus cockpits and driver work places. Thanks to its modular design it can be adapted to a large number of applications.

## DWP+ (Driver WorkPlace)

Driver's workstations offering the ultimate in flexibility, with innovative design and functionally arranged controls. Equipped with the 3 cluster solutions (Multiviù Professional 12, Moki3, BusIC), they allow various possibilities of adaptation to the specific needs of the customer. The color of the pad is customizable to match the color of the vehicle and a wide range of accessories is available as an option.

CON MULTIVIU PROFESSIONAL 12"	CON MOKI 3	CON BUS IC
		

## 4.6 gVCU Generic Vehicle Control Unit

### General description

The device is designed for multiple applications. It is equipped with a powerful 32 bit  $\mu$ controller for Real Time Control algorithms. Application programming must be performed with MathLab® /Simulink® in our model-based development system (MBDS), the operating system is already pre-installed. The PC-based MBDS software development environment compiles and downloads the application program via CAN-Bus to the control unit. The gVCU unit has 2 independent CAN Interfaces compatible with J1939. The third CAN interface is used for software download and diagnostic functions.

### Application

The control unit is without any application program. The user can create his own application program to define I / O functionality. Some inputs are designed for special purposes such as PWM or sensor current sink feature. Several outputs can be used as simple digital switching outputs or as PWM outputs.

### Operative principles

The gVCU system consists of 3 parts:

1. Control Units
2. MBDS - Model Based Development System for configuration and download
3. A set of MathLab® / Simulink® components for the SW application (to be order directly to MathWorks®)



Technical characteristics	
Housing:	Plastic housing with lateral brackets for fixing
Dimension:	218 x 119 x 43.2 mm (without brackets and connector)
Nominal Voltage:	12 / 24V
Operating Voltage:	10 -32 V
Current consumption:	max. 5A @24V
Operating temperature:	from -40 to +80°C
Storage temperature:	from -40 to +90°C (2h)
Protection class	IP40
Quiescent current:	<1mA
Testing acc.	ISO 16750
ESD acc.	ISO 10605
Digital Inputs:	16
Analog Inputs:	12
Frequency inputs:	3
PWM Inputs	2 (for the accelerator pedal)
Inputs for Inductive sender	1
Inputs for resistive senders	1 (for the measurement of the oil level)
HIGH Side Outputs (2A)	4
HIGH Side Outputs (1A)	13
LOW Side Outputs	2
5V supply for sensor (50mA)	2
Immobilizer interface	1 (Active Antenna)
CAN Interfaces	3 (2 * 250kBaud, 1 * 500kBaud)
LIN Interfaces	1

## 4.7 DC-DC converters



The DC-DC converters are used in vehicles with 24V electrical system to allow the use of electronic components and 12V systems (eg radios, navigation systems, DVD players, refrigerators, fans).

### Benefits:

- Costs optimization
- Technical solutions from 5A to 30A loads
- Validated according to the Automotive Standards
- Solutions adaptable to customer needs
- Existing "off the shelf" platforms
- No R&D investments needed

### Main Technical characteristics

- Input voltage range: from 18V to 32V
- Output voltages (typical): 13V +/- 0.5V
- Ripple Max. outputs: 50 mVpp
- Output current: from 5A to 30A
- Current consumption: <1mA

Order Part No.	Current	Picture
A2C1055610001	Up to 7 A	
A2C1055620001	Up to 15 A	
A2C1055630001	Up to 30A	



## 5. Audio Systems

The RDS tuner has a worldwide platform. The frequency and the AM and FM spacing for the Europe / USA / LATAM / ASIA configuration are accessible via the radio menu by the end user. Vehicle manufacturers all over the world no longer worry about which radio to install without knowing the final destination of the vehicle. Some models are equipped with a DAB tuner for digital radio technology and guarantee maximum sound quality.

Each radio has a backup system to store the memory of all user settings and preset stations when the main power is interrupted. The Bluetooth® functionality is now integrated for secure phone conversations and for streaming audio content from your smartphone. The CAN bus feature offer to OE manufacturer a powerful communication data bus for the creation of customized HMI.

### 5.1 Radio

### 5.2 Loudspeakers

### 5.3 Accessories

## 5.1 Radio

The radio proposal has been extended by creating two ranges: VDO brand and Continental brand. The two ranges are the same and stand out only for the color of the backlight: orange for Continental, blue or white for VDO.

All models are available at 12 and 24V and the TR radios have a short chassis to simplify installation in small spaces.

### Main features

#### Tuner RDS - Worldwide platform



**WORLDWIDE  
TUNER**

The AM and FM frequency ranges for Europe, USA, LATAM, Asia and North Africa are accessible from the user menu. It is possible to receive radio stations all over the world!

#### DAB / DAB+ / DMB Digital Audio Broadcasting Tuner



**DIGITAL AUDIO  
BROADCASTING**

DAB + is the new digital radio transmission technology, already used all over the world, for an unprecedented sound quality.

#### USB and Bluetooth®connectivity



**USB CONNECT**



**Bluetooth®**



**MP3/WMA**

It allows the listening of a large number of songs in compressed format on USB key. The Bluetooth® connection makes the phone conversations in a safe and comfortable car, as well as allowing you to listen to your favorite music via streaming with your smartphone.

#### Backup memory / Permanent storage of radio stations and settings



**BACKUP MEMORY**

It stores all stored radio stations and settings when the vehicle battery is disconnected

#### Logic ON/OFF



**LOGIC ON  
LOGIC OFF**

Logic ON limits the use of the radio to an hour after the vehicle is turned off. Logic OFF prevents inadvertent ignition of the radio when the vehicle is switched off.

#### CAN Bus

**CAN-Bus**

The CAN Bus allows the communication data exchange between the radio and an external HMI unit (i.e. intelligent display with touch buttons controls)

#### Sirius XM Ready



Sirius XM Satellite Radio is a broadcasting company that provides three satellite radio and online radio services operating in the United States and Canada

#### Certifications



The CE mark represents the European conformity mark and indicates that the product complies with the respective laws and regulations of the 2014/53 / EU directive

E-mark indicates that the product complies with the requirements on electromagnetic compatibility. Vehicles and their components must have both the E mark and the CE mark in order to be legally sold in Europe.

FCC is the US conformity mark and indicates that the product complies with the respective US laws and regulations or directives. The vehicles and their components must have the FCC certification to be legally sold in the USA.

TR version: without CD, short chassis

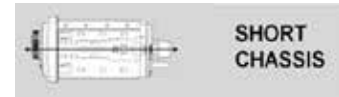

Depth: 10cm

RDS tuner with USB 2.0

Model	Part No.	Display color	Voltage
TR412U-WH	2910000285000	White	12V

External microphone not included

RDS Tuner Bluetooth® and USB 2.0

Model	Part No.	Display color	Voltage
TR412UB-WH	2910000284900	White	12V

External microphone not included

- Radio/USB/MP3/WMA
- 12V / white backlighting
- Worldwide tuner FM/MW/LW
- Tuner FM RDS AF/TA/EON/PTY
- Logic ON/OFF
- BackUp memory
- Front AUX Input
- Bluetooth® HSP, HFP profiles (Hands Free)\*
- Audio Streaming profiles (A2DP, AVRCP)\*

\*only TR412UB-WH



RDS Tuner with USB 2.0

Model.	Part No.	Display color	Voltage
TR711U-BU	TR711U-BU	Blue	12V
TR7411U-OR	TR7411U-OR	Orange	12V
TR722U-BU	TR722U-BU	Blue	24V
TR7422U-OR	TR7422U-OR	Orange	24V

- Radio/USB/MP3/WMA
- 12V and 24V
- Orange (Continental) or Blue (VDO) backlighting
- Worldwide tuner FM/MW/LW
- Tuner FM RDS AF/TA/EON/PTY
- Logic ON/OFF
- BackUp memory
- Front AUX Input

RDS Tuner Bluetooth® and USB 2.0

Model.	Part No.	Display color	Voltage
TR712UB-BU	TR712UB-BU	Blue	12V
TR7412UB-OR	TR7412UB-OR	Orange	12V
TR723UB-BU	TR723UB-BU	Blue	24V
TR7423UB-OR	TR7423UB-OR	Orange	24V

- Radio/USB/MP3/WMA
- 12V and 24V
- Orange (Continental) or Blue (VDO) backlighting
- Worldwide tuner FM/MW/LW
- Tuner FM RDS AF/TA/EON/PTY
- Logic ON/OFF
- BackUp memory
- Front AUX Input
- Bluetooth® HSP, HFP profiles (Hands Free)
- Audio Streaming profiles (A2DP, AVRCP)

RDS Tuner DAB Bluetooth® and USB 2.0

Model	Part No.	Display color	Voltage
TRD7412UB-OR	2910000430600	Orange	12V
TRD7423UB-OR	2910000431200	Orange	24V

- Radio/USB/MP3/WMA
- 12V and 24V
- Orange (Continental) or Blue (VDO) backlighting
- Worldwide tuner FM/MW/LW
- Tuner FM RDS AF/TA/EON/PTY
- Tuner DAB/DAB+/DMB
- Logic ON/OFF
- BackUp memory
- Front AUX Input
- Bluetooth® HSP, HFP profiles (Hands Free)
- Audio Streaming profiles (A2DP, AVRCP)

## CD Versions



### RDS Tuner with CD/MP3 and USB 2.0

Model	Part No.	Display color	Voltage
CD716U-BU	CD716U-BU	Blue	12V
CD7416U-OR	CD7416U-BU	Orange	12V
CD726U-BU	CD726U-BU	Blue	24V
CD7426U-OR	CD7426U-BU	Orange	24V

- Radio/CD/USB/MP3/WMA
- 12V and 24V
- Orange (Continental) or Blue (VDO) backlighting
- Worldwide tuner FM/MW/LW
- Tuner FM RDS AF/TA/EON/PTY
- Logic ON/OFF
- BackUp memory

### RDS Tuner with CD/MP3, Bluetooth® and USB 2.0

Model	Part No.	Display color	Voltage
CD716UB-BU	2910000080700	Blue	12V
CD7416UB-OR	2910000080600	Orange	12V
CD726UB-BU	2910000080800	Blue	24V
CD7426UB-OR	2910000080900	Orange	24V

- Radio/CD/USB/MP3/WMA
- 12V and 24V
- Orange (Continental) or Blue (VDO) backlighting
- Worldwide tuner FM/MW/LW
- Tuner FM RDS AF/TA/EON/PTY
- Logic ON/OFF
- BackUp memory
- Front AUX Input Bluetooth® HSP, HFP profiles (Hands Free)
- Audio Streaming profiles (A2DP, AVRCP)

### RDS Tuner DAB with CD/MP3, Bluetooth® and USB 2.0

Model	Part No.	Display color	Voltage
CDD718UB-BU	CDD718UB-BU	Blue	12V
CDD7418UB-OR	CDD7418UB-OR	Orange	12V
CDD728UB-BU	CDD728UB-BU	Blue	24V
CDD7428UB-OR	CDD7428UB-OR	Orange	24V

- Radio/CD/USB/MP3/WMA
- 12V and 24V
- Orange (Continental) or Blue (VDO) backlighting
- Worldwide tuner FM/MW/LW
- Tuner FM RDS AF/TA/EON/PTY
- Tuner DAB/DAB+/DMB
- Logic ON/OFF
- BackUp memory
- Front AUX Input Bluetooth® HSP, HFP profiles (Hands Free)
- Audio Streaming profiles (A2DP, AVRCP)



	TR7411U-OR TR711U-BU	TR7422U-OR TR722U-BU	TR7412UB-OR TR712UB-BU	TR7423UB-OR TR723UB-BU	2910000284500 2910000284900	CD7416U-OR CD716U-BU	CD7426U-OR CD726U-BU	CDD7418UB-OR CDD718UB-BU	CDD7428UB-OR CDD728UB-BU	291-0000080700 291-0000080600	291-0000080800 291-0000080900
<b>DESIGN:</b>											
Clear, functional design	•	•	•	•		•	•	•	•	•	•
Black matt finished front panel	fix	fix	fix	fix		fix	fix	fix	fix	fix	fix
LCD, Orange/Blue illumination	dot	dot	dot	dot	dot (white ill.)	dot	dot	dot	dot	dot	dot
<b>RADIO RECEPTION:</b>											
DAB/DAB+ (digital radio)		TRD7412UB-OR		TRD7423UB-OR				•	•		
RDS Tuner FM with AF/AM	•	•	•	•	•	•	•	•	•	•	•
Band selection (EU/USA/LATAM/ASIA)	•	•	•	•	•	•	•	•	•	•	•
TA Traffic Announcement	•	•	•	•	•	•	•	•	•	•	•
Autostore (AST)	•	•	•	•	•	•	•	•	•	•	•
<b>CD PLAYER:</b>											
CD mechanics						•	•	•	•	•	•
CD/MP3/WMA						•	•	•	•	•	•
Scan/Repeat/Track/Random Play, Previous/Next, ID3 tags display						•	•	•	•	•	•
Electronic Shock Protection (ESP)						•	•	•	•	•	•
<b>BLUETOOTH:</b>											
HSP/HFP			•	•	• only			•	•	•	•
A2DP/AVRCP			•	•	2910000284900			•	•	•	•
Internal and external microphone			•	•	Only internal			•	•	•	•
<b>USB HOST:</b>											
Front USB connector	standard	standard	standard	standard	standard	standard	standard	standard	standard	standard	standard
USB 1.1/2.0	•	•	•	•	•	•	•	•	•	•	•
MP3/WMA format	•	•	•	•	•	•	•	•	•	•	•
Max size of supported devices	up to 8 GB	up to 8 GB	up to 8 GB	up to 8 GB	up to 8 GB	up to 8 GB	up to 8 GB	up to 8 GB	up to 8 GB	up to 8 GB	up to 8 GB
<b>GENERAL:</b>											
Dimension (W x H x D) mm	185x55,5x108	185x55,5x108	185x55,5x108	185x55,5x108	185x55,5x108	185x54,5x162	185x54,5x162	185x54,5x162	185x54,5x162	185x54,5x162	185x54,5x162
Antenna (ISO/DIN)	DIN	DIN	DIN	DIN	DIN	DIN	DIN	DIN	DIN	DIN	DIN
Operating Voltage	12 V	24 V	12 V	24 V	12V	24 V	24 V	24 V	12 V	12 V	24 V
Output maximum power	4 x 41 W	4 x 41 W	4 x 41 W	4 x 41 W	4 x 45 W	4 x 41 W	4 x 41 W	4 x 41 W	4 x 41 W	4 x 41 W	4 x 41 W
Back up memory	•	•	•	•	•	•	•	•	•	•	•
AUX Input	front	front	front	front	front	rear	rear	rear	rear	rear	rear
Telephone mute (active level, hi-low)			low	low	low	low	low	low	low	low	low
input for steering wheel controls	•	•	•	•	•	•	•	•	•	•	•

## CAN Versions

The CAN bus line included offers an important opportunity to interface with HMI displays able to show the information in attractive graphic layouts and to receive the commands with touch buttons control interfaces. In this way the radio becomes an integral part of the vehicle's information system, to offer a unique multimedia experience. The radios are available either with direct front controls or as a black box that can be mounted hidden in the vehicle.

They are also available with a DAB / DAB + or Sirius XM receiver interface



CAN-Bus

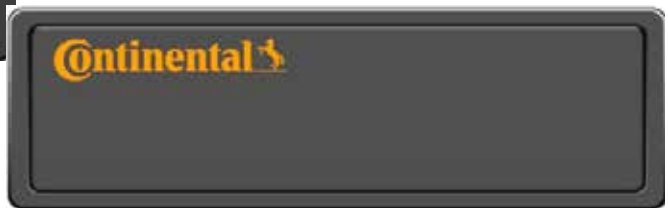

Black box CR4612UBA

### 12V CAN FM RDS Tuner with MP3/WMA/USB/Bluetooth

Model	Part No.	Display color	Voltage
CR4512UBA-OR	2910002093900	Orange	12V
CR4612UBA	2910002094200	- (black box)	12V

#### Design

- Clear and functional Design
- Matt black fixed front
- Dimmable LCD display and buttons (only CR4512UBA-OR)
- Orange illumination (only CR4512UBA-OR)

#### Tuner

- Worldwide FM RDS tuner AF/TA/EON/PTY
- LW, MW, and FM with AST
- 6 preset keys • FM12, FM-AST 6, MW 6, MW-AST 6, LW 6
- RDS clock

#### Bluetooth 4.2

- Cell Phone Hands-Free Profiles (HSP,HFP)
- Audio Streaming Profiles (A2DP, AVRCP)
- Internal and external microphone

#### USB-Host

- Front USB port with 2.1A max. charge
- Support of USB 1.1/USB 2.0
- Support of MP3/WMA format

#### Internal Amplifier

- Max. Music Power: 4x41 Watt
- RMS Power: 4 x 20 Watt
- Sound Presets (Classic, Pop, Rock, Jazz)
- Loudness Function/output for passive subwoofer
- Mute

#### General

- CAN J1939 BUS
- Non volatile memory of settings
- Logic ON/OFF function
- Front and Rear AUX inputs
- Dimensions (WxHxD) in mm: 188x58,5x114,7
- Power supply: 12V (10,8V - 16V)
- DIN/ISO connectors



## 12V CAN FM RDS & DAB Tuner with MP3/WMA/USB/Bluetooth

Model	Part No.	Display color	Voltage
CRD4512UBA-OR	2910002094000	Orange	12V
CRD4612UBA	2910002094300	- (black box)	12V

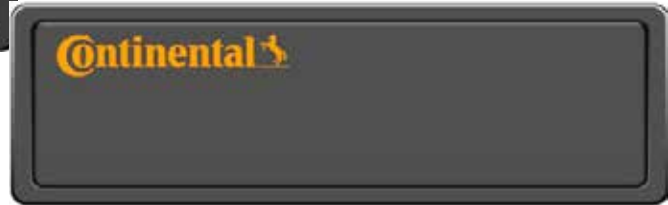

Black box CRD4612UBA

### Design

- Clear and functional Design
- Matt black fixed front
- Dimmable LCD display and buttons (only CR4512UBA-OR)
- Orange illumination (only CR4512UBA-OR)

### Tuner

- DAB / DAB+ Tuner
- Worldwide FM RDS tuner AF/TA/EON/PTY
- LW,MW, and FM with AST
- 6 preset keys • FM12, FM-AST 6, MW 6, MW-AST 6, LW 6
- RDS clock

### Bluetooth 4.2

- Cell Phone Hands-Free Profiles (HSP,HFP)
- Audio Streaming Profiles (A2DP, AVRCP)
- Internal and external microphone

### USB-Host

- Front USB port with 2.1A max. charge
- Support of USB 1.1/USB 2.0
- Support of MP3/WMA format

### Internal Amplifier

- Max. Music Power: 4x41 Watt
- RMS Power: 4 x 20 Watt
- Sound Presets (Classic, Pop, Rock, Jazz)
- Loudness Function/output for passive subwoofer
- Mute

### General

- CAN J1939 BUS
- Non volatile memory of settings
- Logic ON/OFF function
- Front and Rear AUX inputs
- Dimensions (WxHxD) in mm: 188x58,5x114,7
- Power supply: 12V (10,8V - 16V)
- DIN/ISO connectors



CAN-Bus ((SiriusXM)) Ready



## 12V CAN FM RDS & DAB Tuner with MP3/WMA/USB/Bluetooth /Sirius XM ready

Model	Part No.	Display color	Voltage
CRS4512UBA-OR	2910002094100	Orange	12V
CRS4612UBA	2910002094400	- (black box)	12V



Black box CRS4612UBA

### Design

- Clear and functional Design
- Matt black fixed front
- Dimmable LCD display and buttons (only CR4512UBA-OR)
- Orange illumination (only CR4512UBA-OR)

### Tuner

- Worldwide FM RDS tuner AF/TA/EON/PTY
- LW,MW, and FM with AST
- 6 preset keys • FM12, FM-AST 6, MW 6, MW-AST 6, LW 6
- RDS clock

### Bluetooth 4.2

- Cell Phone Hands-Free Profiles (HSP,HFP)
- Audio Streaming Profiles (A2DP, AVRCP)
- Internal and external microphone

### USB-Host

- Front USB port with 2.1A max. charge
- Support of USB 1.1/USB 2.0
- Support of MP3/WMA format

### Sirius XM

- Compatibility with external Sirius module SXV-300

### Internal Amplifier

- Max. Music Power: 4x41 Watt
- RMS Power: 4 x 20 Watt
- Sound Presets (Classic, Pop, Rock, Jazz)
- Loudness Function/output for passive subwoofer
- Mute

### General

- CAN J1939 BUS
- Non volatile memory of settings
- Logic ON/OFF function
- Front and Rear AUX inputs
- Dimensions (WxHxD) in mm: 188x58,5x114,7
- Power supply: 12V (10,8V - 16V)
- DIN/ISO connectors



### 5.3 Loudspeakers

The VDO speakers faithfully reproduce the pure sound that good music deserves. Their power and sensitivity are compatible with the whole range of the VDO radios.



**Loudspeakers**      Loudspeaker 10 cm 2 ways, 50W      Loudspeaker 10cm 2 ways, 50W, screwable grille      Loudspeaker 13 cm 2ways, 60W      Loudspeaker 13cm 2 ways, 60W, screwable grille      Loudspeaker 13 cm 2 ways, 60W, white grille

Model Number	HP1021	HP1022	HP1321	HP1322	HPW1321/16
Part Number	HP1021	2910000251700	HP1321	2910000251900	HPW1321/16
EAN Code	4103590678065	4103590676771	4103590676979	4103590676740	4103590676986
Peak load (W)	50	50	60	60	60
Maximum load (W)	12	12	15	15	15
Sensibility (dB)	88	88	89	89	89
Frequency response (Hz)	120-18.000	120-18.000	90-18.000	90-18.000	90-18.000
Installation depth	47	47	44.5	44.5	44.5
Diameter (mm)	100	100	130	130	130
Nominal resistance	4	4	4	4	4
Grille color	Black (zinc plated)	Black uniblock (zinc plated)	Black (zinc plated)	Black uniblock (zinc plated)	White (RAL 9016) (zinc plated)
Cone material	Injected PP	Injected PP	Injected PP	Injected PP	Injected PP
Structure material	Metal	Metal	Metal	Metal	Metal
Accessories	Screws	Screws	Screws	Screws	Screws
Packing	1 pair	1 pair	1 pair	1 pair	1 pair
Quantity in a package	10 prs	10 prs	10 prs	10 prs	10 prs
Net weight (kg)	6.5	7.2	8.2	9.5	9.5
Gross weight (kg)	10	11	12.8	14	15.5



**Loudspeakersi**

Loudspeaker 10 cm  
2 ways bulk, 50W

Loudspeaker 10 cm  
2 ways bulk, 110W

Loudspeaker 13 cm  
dual cone bulk, 50W

Loudspeaker 13 cm  
2 ways bulk, 50W

Loudspeaker 13 cm  
dual cone bulk, 50W  
con griglia

Model Number	HP1021/B	HPS1021/B	HP1311/B	HP1321/B	HPG1011/B
Part Number	HP1021/B	2910000256700	2910000252000	2910000251800	2910000307300
EAN Code	4103590676955	4103590676962	4103590676764	4103590676757	4103590952822
Peak load (W)	50	110	60	60	60
Maximum load (W)	10	25	15	15	10
Sensibility (dB)	86	87	86	88	88
Frequency response (Hz)	120-18.000	120-20.000	90-16.000	90-18.000	120-16.000
Installation depth	47	42	43	44.5	37.5
Diameter (mm)	100	100	130	130	100
Nominal resistance	4	4	4	4	4
Grille color	-	-	-	-	Black uniblock (zinc plating)
Cone material	Injected PP	Injected PP	Injected PP	Injected PP	Injected PP
Structure material	Metal	Metal	Metal	Metal	Metal
Accessories	No	No	No	No	No
Packaging	30	30	40	40	30
Quantity in a package	30 pcs	30 pcs	40 pcs	40 pcs	30 + 30 pcs
Net weight (kg)	95	14	16.5	16.7	8.5
Gross weight (kg)	10.5	15.4	18.3	18.5	9.6



**Loudspeakers**

Round grille, 10cm  
bulk, black

Round grille, 10cm  
bulk, Black (30pcs)

Round grille (for  
HPS1021/B) bulk,  
Black (30pcs)

Square grille, 10cm  
bulk, Black





Round grille, 13cm  
bulk, Black

Marine  
Loudspeaker  
13cm, 2vie, white  
grille ASA 150W



Model Number	051-018-0000	015-018-000/30	051-018-0005	XRC-1-96-101	051-018-003	051-018-011
Part Number	051-018-000	2910000251500	2910000329500	XRC-1-96-101	2910000251600	051-018-011
EAN Code	4103590676993	4103590676795	4103590677280	4103590677006	4103590676788	4103590677013
Peak load (W)	-	-	-	-	-	200
Max. load (W)	-	-	-	-	-	30
Sensibility (dB)	-	-	-	-	-	87
Frequency response (Hz)	-	-	-	-	-	80-20.000
Installation depth	-	-	-	-	-	50
Diameter (mm)	100	100	100	100	130	130
Nominal resistance	-	-	-	-	-	4
Grille color	Black uniblock (zinc plated)	Black uniblock (zinc plated)	Black uniblock (zinc plated)	Black uniblock	Black uniblock (zinc plated)	White (RAL 9003)
Cone material	-	-	-	-	-	Injected PP
structure material	-	-	-	-	-	ASA (UV resistant)
Accessories	No	No	No	No	No	Screws and 2 ISO cables
Packaging	100	30	30	50	40	1 pair
Quantity in a package	100 pcs	30 pcs	30 pcs	50 pcs	40 pcs	10 prs
Net weight (kg)	4	tbd	1.65	1.65	1.9	12.5
Gross weight (kg)	4.5	tbd	2	2	2.5	15

## 5.3 Accessories

### Antennas

Order No.	Description	Color	Rod	cable lenght
2910000111300 2910000291700 (version without cable)	Rigid AM/FM antenna for roof mounting 35mm 10-123 	Black	Glass fibre 348 mm	2,30 mt
10-124	Flexible AM/FM Antenna for roof mounting 	Black	Rubber 190 mm	2,30 mt
10-125E	Amplified antenna 15dB AM/FM for windscreen mounting 	Black	280 mm	1,50 mt
2910000144900	Passive DAB antenna for windscreen mounting 	Black		
2910000502900	Active "L" DAB antenna 	Black	-	3 mt - with SMB connector

### Cables and adapters

Order Part No.	Description
561-060	Coaxial extension cable (DIN, male and female connection) lenght 3500mm 
2910000075300	FAKRA to DIN adapter for passive antennas 
2910000075400	FAKRA to DIN adapter for amplified antennas 
2910000307400	Antenna cable 1,50 mt (for 10-123)
2910000291800	Antenna cable 2,40 mt (for 10-123)
2910000417400	Antenna cable 2,80 mt (for 10-123)
2910000272400	External microphone for Bluetooth® radios
2910000457200	Auxiliary input cable C1 with SRWC
2910000152300	1DIN housing
CA0504U-LS	ISO cables for supply and loudspeaker



## 6. View systems

The VDO view systems represent a solution to increase workplace safety and limit the risks associated with vehicle mobility during maneuvering operations. VDO offers a wide range of products, which are able to meet all the requirements mentioned in the European machinery legislation.

6.1 ProViu®ASL360

6.2 Rear View System Pro Line



## 6.1 ProViu®ASL360

### Greater awareness and confidence thanks to all-round vision

Human error whilst executing driving maneuvers is the most common cause of personal injury accidents involving vehicles.

ProViu®ASL360 has been developed with this in mind and assist in risk reduction of avoidable accidents and incidents. Four cameras stitched together provide a meaningful 360° all-round view, reducing blind spots and displaying pedestrians and other obstacles.

ProViu®ASL360 enables the user to see obstacles that may not usually appear in direct vision or mirrors. Thus the system improves the ease of maneuvering whilst decreasing the risk of accidents. Ultimately this helps increase efficiency via shorter turnarounds and downtimes, lower repair and damage costs and a lower level of associated risk. ProViu®ASL360 also greatly facilitates vehicle operation in critical situation such as: dense city traffic, narrow loading areas, cluttered factory yards and at bustling building sites etc.



### Functional principle

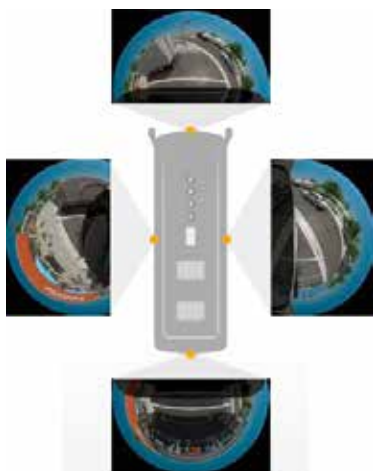

1\_ Installed cameras enable the driver to see 360° around the vehicle



2\_ The recorded images are transmitted to the control unit

3\_ The transmitted images are adjusted perspectively and consolidated to create a preview



4\_ The preview is transmitted to the display in the driver's cab

5\_ The view can be configured individually and therefore shows an ideal view that is tailored to the driver's needs

## Advantages at a glance

- Passive system
- No blind spots - because 4 wide-angle fish-eye cameras create 4 x 180° plus images, which the system then combines, stitches, blends and grades to produce a perfect, all-round view from above the vehicle
- Fast, real-time image delivery - 30 fps
- Spot-on accuracy - and a flexible software tool chain, with multiple screens, configuration, custom user interface and much more

- Reliability - self monitoring system, guaranteeing no frozen frames up to output
  - Hardware - fully certificated
  - Customized view - just move the joins between the images to suit the current vehicle location
  - Cutting-edge technology - Continental is and industry leader
- Support - fast, efficient support is system changes are requested

## ProViu®ASL360 - the Hardware

The hardware in any monitoring system must have cutting-edge technology. It must also be durable and of course totally reliable. ProViu®ASL360 has proven to be simply outstanding indeed surviving the frozen Antarctic wastes and the boiling heat of the desert.

## Camera



- 4 X asl360 CMOS cameras
- 180° plus lenses
- Horizontal viewing angle
- Intelligent camera (software driven, light balance etc.)
- Robust IP 69K rating

## ASL360 Electronic Control Unit



- 4 -6 real time 30 fps inputs
- Multiple real time 30 fps outputs
- Normal voltage 12-24V, operating voltage 9 -32V
- Operating temperature -40°C ... +85°C
- Fully approved for factory or retrofit applications
- EMC (Electromagnetic Compatibility) in conformance with CE, ECE-R10 (E11 label), FCC

## Examples of applications

City bus and Trip bus



Construction Vehicles, Mobile Crane, Excavators



Tractors and Combine Harvester



General Truck, Delivery Vehicles



Garbage Truck



## Technical Data

Technical Data ECU	
Video Output	SVGA (800 x 600 pixels), VGA, Pal or NTSC
Video Output Connections	VGA Connector (Standard), M12 Connector (Standard) (Dual Composite Video Output)
PC Output	M12 to RJ45 Connector Available (Ethernet)
Camera Inputs	6
Max. concurrent camera images	4
Housing	Die-cast Aluminium; 225 x 120 x 35mm
Nominal Voltage	12 / 24V
Operating Voltage	9 / 32V
Over Voltage protection	The system shall withstand a supply voltage up to +36 VDC for 5 minutes
Reverse polarity protection	Yes
Current consumption	max. 1A@12V with 6 cameras
Operating / Storage Temperature	-40 ... +85°C / -40 ... +85°C
EMC in conformity with (Electromagnetic compatibility)	CE, ECE-R10 (E11 label), FCC
Vibration	Vibration test for ISO 16001 / ISO 15998 5Hz to 9Hz peak to peak amplitude: 42mm - 9Hz to 200Hz acceleration: 50m/s <sup>2</sup> , Sweep rate: 1oct/min / 2 hours each axes
Mechanical Shock	Mechanical shock tests (bare unit) DIN EC IEC 60068-2-27 (Test Ea) - Half sine wave 400 m/s <sup>2</sup> for 6ms, 100 shocks in all 3 axes, both directions

Technical Data Cameras	
Wide angle Fisheye Camera with Infrared Filter	
Field of View	180°
Viewing angle	Horizontal
Connector Type	M12
Video Signal	PAL
Vibration	Vibration test for ISO 16001 / ISO 15998 5Hz to 9Hz peak to peak amplitude: 42mm - 9Hz to 200Hz acceleration: 50m/s <sup>2</sup> , Sweep rate: 1oct/min / 2 hours each axes
Mechanical Shock	Mechanical shock tests (bare unit) DIN EC IEC 60068-2-27 (Test Ea) - Half sine wave 400 m/s <sup>2</sup> for 6ms, 100 shocks in all 3 axes, both directions
Minimum illumination	0,1 LUX
Minimum supply Voltage	9V
Weight	272 g
Salt spray	a. Salt concentration: 5%+/-1% Sodium Chloride (NaCl) b. pH value 6,5 - 7,2 c. Temperature: 35°C +/- 2°C d. Spray Volume: 1-2 ml/80cm <sup>2</sup> /hour e. 24H
Protection class	IP6K9K

## Order Part Numbers

Order Part No.	Description
2910000982100	ASL 360 System Kit (ECU + 4 cameras)
A2C59517173	ASL 360 System Kit (ECU + 3 cameras)
A2C59516759	ASL 360 Camera cable 10m
A2C59516760	ASL 360 Camera cable 15m
A2C59516761	ASL 360 Camera cable 20m
A2C59516762	ASL 360 Camera cable 2,5m
A2C7449840000	ASL 360 Camera cable 6,5m
A2C59516767	ASL 360 Ethernet Setup Cable
A2C59516758	ASL 360 Software license

## Camera dimensions

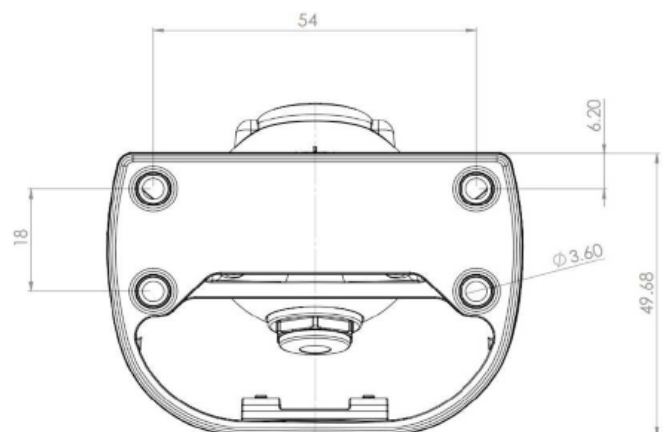

## Spare Parts

Order Part No.	Description
2910000951700	ASL 360 Camera (black edition)**
2910000982000	ASL 360 Control Unit **
2910000466100	ASL 360 9" Touch Monitor

\*\* ASL 360 Camera always includes plastic cover

\*\* ASL 360 Control Unit (ECU) always includes Video Splitter Cable & System Cable ECU

## 6.3 Rear View System Pro Line

### Cameras

- Applications: Heavy vehicles, Agricultural vehicles / Off-road / Special Vehicles.
- Automatic activation with rear gear
- Extension cables to be ordered separately

#### Cameras Technical Data (signal broadcasting via cable)

				
Model N°	CC-VD0120KG	CC-VDO120KB	CC-VDO120K	CC-VDO120K
Order Part No.	2910000118700	2910000854700	2910000119000	2910000118800
View angle	120°	120°	150°	120°
Side mounting	-	-	-	-
Resolution	756 x 504 pixels	756 x 504 pixels	976 x 582 pixels	976 x 582 pixels
Sensibility (Lux)	< 0,1 Lux (Cmos sensor)	< 0,1 Lux (Cmos sensor)	< 0,1 Lux (CCD sensor)	< 0,1 Lux (CCD sensor)
Automatic brightness	•	•	•	•
LED IR night vision	• (10m)	• (10m)	• (10m)	• (10m)
Number of LEDs	4	4	6	6
Built-in microphone	•	•	•	•
Built-in heater	-	-	-	•
Motorized shutter	-	-	-	•
Mirror mode	•	-	•	-
Resistance to vibrations	6G	6G	10G	10G
IP protection class	IP69K	IP69K	IP69K	IP69K
Video output	1,0 vp_p, 75 Ohm PAL	1,0 vp_p, 75 Ohm PAL	1,0 vp_p, 75 Ohm PAL	1,0 vp_p, 75 Ohm PAL
Temperature range	from -20 a +70°C	from -20 a +70°C	from -20 a +70°C	from -20 a +70°C
Max. Current consumption	250mA	535 mA	300mA	150mA
Dimensions	75 x 62 x 59 mm	75 x 62 x 59 mm	86 x 60 x 71 mm	88 x 75 x 65 mm
Weight	375g	375g	365g	375g
Color	Silver	Black	Silver	Silver

Application Note: wireless camera for forklift



**Technical Data side mounting and built-in mounting cameras (signal broadcasting via cable)**

			
Model N°	CC-VDOS150K	CC-VDOB150	CC-VDOB120
Order Part No.	2910000119100	2910000781100	2910000119200
View angle	150°	150°	120°
Side mounting	•	-	-
Resolution	976 x 582 pixels	640 x 480 pixels	976 x 582 pixels
Sensibility (Lux)	< 0,1 Lux (CCD sensor)	< 0,1 Lux (CCD sensor)	< 0,1 Lux (CCD sensor)
Automatic brightness	•	•	•
LED IR night vision	• (5m)	-	• (10m)
Number of LEDs	6	-	9
Built-in microphone	•	-	-
Built-in heater	-	-	-
Mirror mode	-	-	-
Resistance to vibrations	10G	6G	6G
IP protection class	IP69K	IP67	IP67
Video output	1,0 vp_p, 75 Ohm PAL	1,0 vp_p, 75 Ohm NTSC	1,0 vp_p, 75 Ohm PAL
Temperature range	from -20 to +70°C	from -20 to +70°C	from -20 to +70°C
Max. Current consumption	150mA	200mA	200mA
Dimensions	68 x 56 x 41 mm	24,9 x 25 mm	42 x 31 mm
Weight	160g	80g	85g
Color	Black	Black	Black

**Technical Data WIRELESS Cameras**

			 for forklift
Model N°	CC-VDO120F	CC-VDO120FQ **	CC-VDO45FQ **
Order Part No.	2910000119500	2910000242600	2910000814500
View angle	120°	120°	45°
Side mounting	-	-	•
Resolution	512 x 582 pixels	512 x 582 pixels	756 x 504 pixels
Sensibility (Lux)	< 0,1 Lux (CCD sensor)	< 0,1 Lux (CCD sensor)	< 0,1 Lux (CCD sensor)
Automatic brightness	•	•	•
LED IR night vision	• (10m)	• (10m)	•
Number of LEDs	12	12	3
Built-in microphone	•	•	-
Wireless range	100m	100m	50m
Built-in heater	-	-	-
Motorized shutter	-	-	-
Mirror mode	•	•	-
Resistance to vibrations	10G	10G	6G
IP protection class	IP69K	IP69K	IP69K
Video output	1,0 vp_p, 75 Ohm PAL	1,0 vp_p, 75 Ohm PAL	1,0 vp_p, 75 Ohm PAL
Temperature range	from -20 to +70°C	from -20 to +70°C	from -20 to +70°C
Max. Current consumption	300mA	300mA	300mA
Dimensions	86 x 72 x 66 mm	86 x 72 x 66 mm	130 x 50 x 40 mm
Weight	490g	490g	300g
Color	Black	Black	Silver

\*\* Compatible only with Wireless QUAD monitor (CM-VDOFQ700)

## Monitor

- Applications: Heavy duty vehicles, Agricultural vehicles / Off-road / Special vehicles.
- Automatic activation with rear gear
- Extension cables not included

### Technical Data Monitor





Model No.	HDM-VDO710	HDM-VDOS700	CM-VDOS900	HDM-VDOWS700
Order Part No.	2910000299900	2910000118100	2910000118200	2910000118300
Dimensions / Resolution	7" / 1024 x 600 pixels	7" / 1024 x 600 pixels	9" / 800 x 480 pixels	7" Wide, 1024 x 600 pixels
Brightness (cd/mq)	400	400	400	400
Voltage supply	12/24V	12/24V	12/24V	12/24V
Current consumption	6W	6W	6W	6W
Operating Temperature	from -20°C a +70°C	from -20°C a +70°C	from -20°C a +70°C	from -20°C a +70°C
Built-in loudspeaker	•	•	•	•
No. of camera inputs	3	3	3	3
Automatic activation with rear gear	•	•	•	•
Parking assistance	•	•	•	•
Remote control	•	•	•	•
Universal bracket	•	•	•	•
Touch keys	-	•	•	•
Waterproof	-	-	-	•
Touch Screen	-	-	-	•
Dimensions (L x A x P)	182 x 122 x 43 mm	194,6 x 128 x 39,3 mm	234 x 158 x 40 mm	197,2 x 132 x 30,5 mm

### Technical Data Monitor QUAD



Model N°	CM-VDOQ710	CM-VDOWSQ700	CM-VDOSQ900
Order Part No.	2910000979800	2910000118400	2910000118500
Dimensions / Resolution	7" / 800 x 480 pixels	7" Wide / 800 x 480 pixels	9" / 800 x 480 pixels
Brightness (cd/mq)	400	400	400
Voltage supply	12/24V	12/24V	12/24V
Current consumption	10W	20W	25W
Operating Temperature	from -20°C a +70°C	from -20°C a +70°C	from -30°C a +70°C
Built-in loudspeaker	•	•	•
No. of camera inputs	4	4	4
Automatic activation with rear gear	•	•	•
Parking assistance	•	•	•
Remote control	•	•	•
Universal bracket	•	•	•
Touch keys	-	•	•
Waterproof	-	• (IP69K)	-
Touch Screen	-	•	-
Dimensions (L x A x P)	180 x 120 x 20 mm	197,2 x 132 x 30,5 mm	234 x 158 x 40 mm

Technical Data Monitor WIRELESS		Ricevitore Wireless	
			
Model No.	CM-VDOF700	CM-VDOFQ700	IC-VDORC
Order Part No.	2910000118600	2910000244300	2910000120100
Dimension / Resolution	7" / 800 x 480 pixels	7" / 800 x 480 pixels	Receiver for Wireless Camera CC-VDO120F
Brightness (cd/mq)	400	400	
Built-in loudspeaker	•	•	n.a.
No. of camera inputs	4	4	n.a.
QUAD	-	•	n.a.
Voltage supply	12/24V	12/24V	12/24V
Current consumption	6W	6W	4W
Operating Temperature	from -20°C to +70°C	from -20°C to +70°C	from -20°C to +70°C
Resistance to vibrations	7,5G	7,5G	7,5G
Dimensions (L x A x P)	182 x 122 x 43 mm	182 x 122 x 43 mm	105 x 25 x 105 mm
Weight	1010 g	1010 g	325 g
Automatic activation with rear gear	•	•	n.a.
Parking assistance	•	•	
Remote control	•	•	
Universal bracket	•	•	
Touch keys	-	-	
Touch Screen	-	-	

## Rear View KITS

- Applications: Heavy duty vehicles, Agricultural vehicles / Off-road / Special vehicles.
- Fixing accessories and extension cable of 20mt are included in the package.

Rear View KITS						
Description KIT	Color KIT 7" IP69K	Color KIT 7" IP69K with Touch keys	Color KIT 7" IP69K with Monitor Waterproof	Color KIT 7" Digital Wireless	Color KIT 7" QUAD Digital Wireless	Color KIT 9" IP69K with Touch keys
Model No.	RVS-VDO7010	RVS-VDOS7000K	RVS-VDOWS7000K	RVS-VDOF7000K	RVS-VDOFQ7000K	RVS-VDOS9000K
Order Part No.	2910000300600	2910000117200	2910000117300	2910000117500	2910000244200	2910000117400
Included Camera	CC-VDO120KG	CC-VDO120K	CC-VDO120K	CC-VDO120F	CC-VDO120FQ	CC-VDO120K
Included monitor	HDM-VDO710	HDM-VDOS700	HDM-VDOWS700	CM-VDOF700	CM-VDOFQ700	CM-VDOS900



## Accessories - Rear View System Pro Line

Model -.	Order Part No.	Description	
CB-VDO03	2910000463400	Extension cable lenght 3mt	
CB-VDO05	2910000119600	Extension cable lenght 5mt	
CB-VDO10	2910000119700	Extension cable lenght 10mt	
CB-VDO20	2910000119800	Extension cable lenght 20mt	
	2910000119900	spiral cable for trucks+trailer, 1 camera input, lenght. 5mt	
	2910000280600	Adjustable Universal bracket for monitor fixing	
<b>Accessories for Wireless cameras</b>			
BAT-VDO7800	2910000814500	<ul style="list-style-type: none"> <li>• Battery capacity: 7800 mAh</li> <li>• Charge time: 8h</li> <li>• Discharge time: 14H (160mA@11,1V)</li> <li>• Protection class: IP65</li> <li>• Operating Temperature: from -20°C to +60°C</li> <li>• Current consumption: 300mA</li> <li>• Dimensions: 100,5 x 64,5 x 40,7 mm</li> <li>• Weight: 450g</li> </ul>	
ACDC-VDO7800		<ul style="list-style-type: none"> <li>• Input Voltage: 220V</li> <li>• Output Voltage: 12V</li> <li>• Operating Temperature: from -20 to +60g</li> <li>• Dimensions: 100,5 x 64,5 x 40,7 mm</li> <li>• Weight: 300g</li> </ul>	

# 7. Solutions and Applications

	Single Gauges	Analog Instrument Clusters	CAN Instrument Clusters	Sensors and Switches	Sensors - Specific solutions for engine management	Sensors - Specific solutions for chassis	Fuel and Water level Senders	Control Systems	Audio systems	View systems and ADAS	
<b>Applications</b>	<b>ON-HIGHWAY</b>										
	Passenger cars			•		•	•			•	•
	Mobile Cranes	•		•	•	•	•	•	•	•	•
	Bus			•	•	•		•	•	•	•
	Trucks			•	•	•		•	•	•	•
	Special purpose vehicles	•	•	•	•	•	•	•	•	•	•
	<b>OFF-HIGHWAY</b>										
	Construction vehicles	•	•		•	•	•	•	•	•	•
	Agricultural vehicles			•	•	•	•	•	•	•	•
	Industrial trucks	•		•	•	•	•	•	•	•	•
	Forestry vehicles	•	•	•	•	•	•	•	•	•	•
	Special vehicles	•	•	•	•	•	•	•	•	•	•
	<b>LEISURE VEHICLES</b>										
	Power sport vehicles			•			•	•		•	•
	Motorcycles		•	•			•	•			
	<b>STATIONARY MACHINERY</b>										
	Engines	•			•						
	Generators	•			•	•		•			
	Compressors				•			•			
	engine-powered equipment	•			•	•		•	•		

Company  
Street... No...  
zip code, City, Country  
Phone No.  
Fax No.

[www.vdo.com](http://www.vdo.com)  
[www.continental-corporation.com](http://www.continental-corporation.com)  
VDO - A Trademark of the Continental Corporation

The information provided in this catalog contains only general descriptions or performance characteristics that may not always be applicable in real applications in the manner described and / or that may change as a result of further product development. The information contained herein is only a technical description of the product and is not specifically intended to guarantee a specific quality or duration of service. The obligation to provide the desired characteristics exists only if this has been expressly agreed in the terms of the contract. The right is reserved to change delivery options and make technical changes.

Edition 2018

The logo consists of the letters 'VDO' in a bold, blue, sans-serif font. The 'V' and 'D' are connected, and the 'O' is a simple circle.